

*Removable cylinders available
for kwik re-keying*

2004

REKEYING MANUAL

Kwikset[®]

Kwikset
UltraMax
SECURITY

Kwikset
Maximum
SECURITY

Kwikset
Security

Rekeying Is A Great Customer Service That's Easy To Learn.

When customers buy a new entry lockset, deadbolt or handleset, they also want the convenience of having one key operate all the locks in their home. Most customers are not aware that rekeying services exist. They go through life adding more and more keys to an already overcrowded key ring. Locksmiths provide valuable rekeying services and, for extra customer convenience, so are more and more hardware stores. That's where you come in. You can help make your account more profitable and more convenient for their customers.

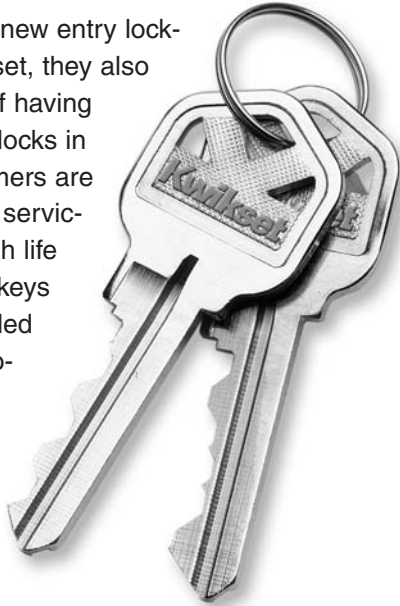

Let's say you sell a new Kwikset Security, Maximum Security, UltraMax Security or Society Brass deadbolt. Ask your customer if he or she also has a entry lockset. If so, would they like you to make their existing key work with the new deadbolt? It will only take a few minutes and cost a few dollars. Most customers will consider that a real convenience and you'll have made an extra sale.

Naturally, it works in reverse, and it works if the customer buys both a deadbolt and an entry lockset or handleset. You ask for their existing key, follow the procedures you'll learn in this manual and you have a happier customer. If they have a competitors brand, the Kwikset Keying Station may allow you to exchange UltraMax cylinders for their existing brand.

Before we go into the mechanics of how one key can do it all, first let's define some terms, then take a quick look at how locks work.

Terminology: When keying two locks alike, you are actually changing the pin-tumblers in one of the locks so that it will have the same "cut combination" as the other. Therefore, "repinning" is a more accurate word to use than "rekeying" But that's what it has been called for generations and we're not about the change that. "Keying alike" is just another term for rekeying.

UltraMax's Superior Engineering Makes Rekeying Even Easier.

If your customer has chosen the UltraMax brand, your job is even easier (in most cases).

When your customers purchase an UltraMax knob, deadbolt, lever, or handleset, they have selected a superior product which provides them with the extra security and peace of mind they need. A single key for all their locks in their home adds security as well as convenience. That feeling of security is what your customers are looking for. All you need is the key that they would like to use for all of their locks.

UltraMax & The Society Brass Collection's six-pin key.

Some Kwikset locks, and most other brands as well, are made with a six-pin cylinder so there are more key cut combinations, which make it more difficult to pick and less likely that any two people will have matching keys. It does not mean that it is more difficult to rekey. In fact, in some circumstances, it's easier. And there is no problem keying a six-pin lock to match a five-pin lock.



The Society Brass Collection uses the Solid Brass six-pin cylinder, eliminating the need of lubricant, which makes it easier to re-key, as well as eliminating the chance of the pins collecting dust and sand.

UltraMax's removable cylinder: UltraMax's knobs have a special cylinder that is removable in seconds with the control key. This will save you time and be convenient for your customers.

In the pages that follow, you will learn how to rekey a Kwikset entrance lockset, a key-in-lever, a single-piece entrance handleset and a security deadbolt. While most of these techniques are the same, there are some subtle differences in how you take the locks apart and put them back together or change out the cylinders.

You'll also learn how to gauge the cuts of a key so you will be able to read it's "combination" and select the proper size pins. Let's get underway.

Contents

How a Lock Works	2	Rekeying Handlesets	22
Tools to Rekey.	3	Rekeying Deadbolts	24
How to Gauge a Kwikset Key	4	Rekeying 780 Deadbolt.	27
Key Duplication	5	with a control key	
Masterkeying	6	Rekeying 780 & 980 Deadbolt	30
Keying Master Cylinders	7	without a control key	
Rekeying Knobs	8	Rekeying 780 & 980 Deadbolt	32
Rekeying Laurel Eggknob	12	without a key or control key	
Rekeying Knobs	14	Rekeying 980 Deadbolt.	33
with a control key		what to do if top pins and springs drop out during rekeying	
Rekeying Knobs	16	The Society Brass Collection	
with a standard operating key but without a control key		Rekeying Knobs & Levers.	35
Rekeying Knobs	19	Rekeying Low Profile Deadbolt.	37
what to do if top pins and springs drop out during rekeying		with existing key	
Rekeying Levers	20	Rekeying Low Profile Deadbolt.	38
Rekeying Levers	21	without existing key or if springs have fallen out	
for Commercial Series levers			

Glossary of Terms

bitting	key cuts that form the combination.	mechanism module	keyed entry lockset assembly for new keyed handlesets.
blade	the portion of a key and/or milling.	PK holes	Protecto Key, allows new homes to be keyed to a builder's key, and once homeowner uses their key, builder is locked out.
bow	the portion of the key which serves as a grip or handle.	plug	holds the bottom pins and keyway.
bow stop	a type of stop located near the key bow.	plug follower	used to push the plug out and hold top pins and springs in place while rekeying plug.
chamber	any cavity in a cylinder plug and/or shell which houses the tumblers.	plug retainer	"C" style clip, holds plug in cylinder housing.
combinate	the pinning of the actual cuts on the key.	shear line	when the bottom pins are correct, a shear line is created when the proper key is inserted allowing rotation of plug.
Control Key	available for most TITAN products, allows removal of cylinder without dismantling lock.	shield	for additional security on exterior knobs.
cylinder assembly	holds the plug, pins, springs and cover.	sleeve	assembly holding cylinder and lever.
cylinder guard	heavy duty cover for cylinder housing.	spindle	two types; a round and half-round spindle.
cylinder housing	contains the cylinder assembly.	spring cover	snap on cover to hold pin springs in place.
cylinder removing tool	for removing and replacing plug retainer.	spring housing	holds return spring for lever or knob in place.
gauge	the act of determining the bitting of the key	tailpiece	spindle like extension for deadbolts.
handing	the orientation of the knob, handle, or lever with respect to a left or right sided door (see illustration on page 20).	thumbpiece pin	holds the handlesets thumbpiece in place.
lever catch	spring mounted piece, holds lever in place		
locking bar	prevents removal of UltraMax cylinder without Control Key use or retainer removal.		

How a Lock Works

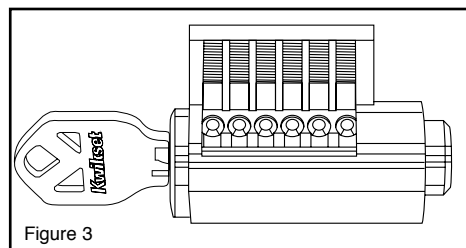
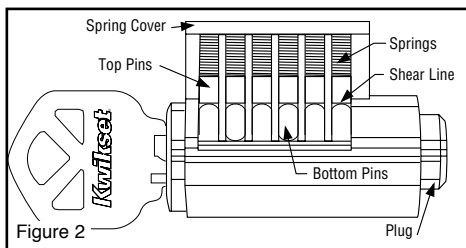
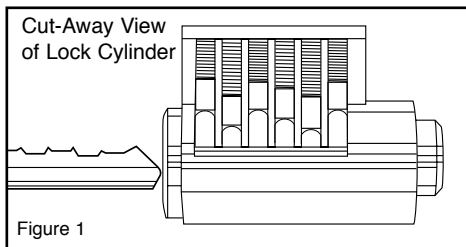
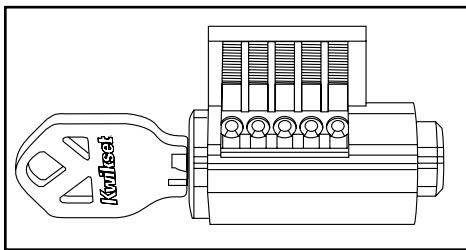
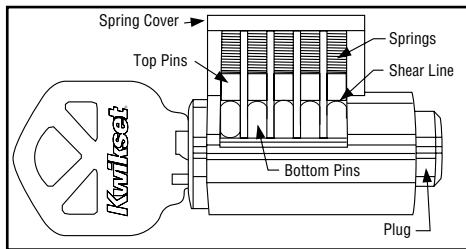
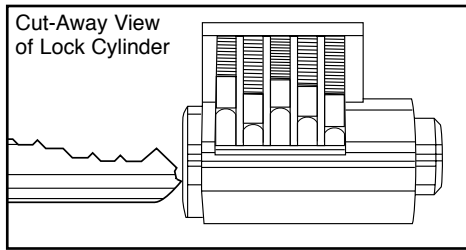

5-Pin System

Kwikset locks operate by matching the cuts on the keys with the bottom pin tumblers inside the cylinder plug.

There are two sets of five pins in each lock, top and bottom, and a set of springs. The top pins are all the same size and are flat on both ends. You do not, at least right now, want to deal with top pins or springs.

You only want to deal with bottom pins, which are of different lengths (in .023" increments) and are tapered on both ends.

For the lock to work, the cuts of the key must enable all five bottom pins to be flush with the cylinder plug. This is called the shear line.

In the top photo, there is no shear line because some bottom pins are out of place. That key won't operate this lock.

Put in the correct key (middle photo) and all the pins line up to form the shear line and the key will operate the lock (bottom).

When you rekey a lock, you simply replace the bottom pins according to the cut combination of the key you want to use. And you can do all this with a few very simple tools.

6-Pin System

UltraMax Security locks operate by matching the cuts on the keys with the bottom pin tumblers inside the cylinder plug.

There are two sets of six pins in each lock, top and bottom, and a set of springs. The top pins are all the same size and are flat on both ends.

You only want to deal with bottom pins, which are of different lengths (in .023" increments) and are chamfered on both ends.

For the lock to work, the cuts of the key must enable all six bottom pins to be flush with the cylinder plug. This area is called the shear line.

In the top photo (Figure 1), with no key or the incorrect key, some bottom pins and some top pins block the shear line. That key won't operate this lock.

In the middle photo (Figure 2), with the correct key, all the pins line up at the shear line. The key will turn and operate the lock (Figure 3).

When you rekey a lock, you simply replace the bottom pins according to the "bitting" (cut combination) of the key you want to use.

Tools to Rekey

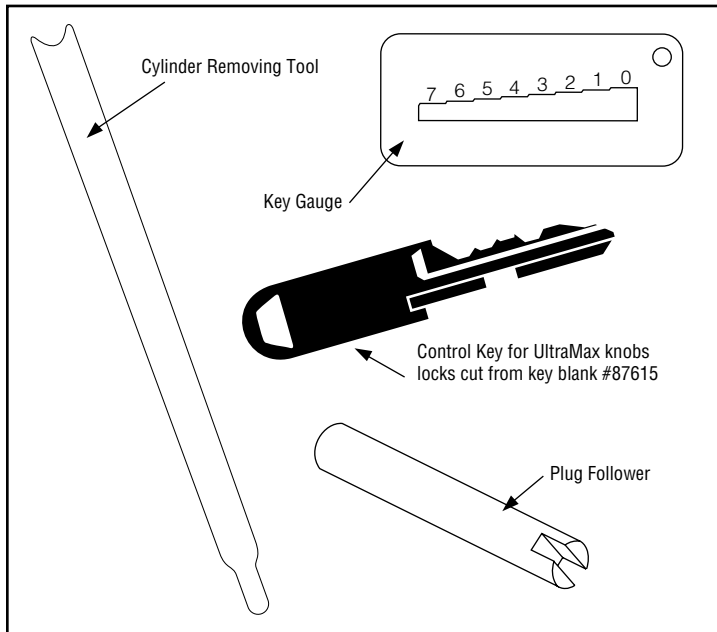

Inside a Kwikset/Society Brass Collection Rekeying Kit are the different bottom pin sizes you need to rekey a lock, a Key Gauge for reading the cuts on a key, a Cylinder Removing Tool (affectionately known as a “pickle fork”), and a plug follower. This is a very simple device which keeps lock parts from scattering across the room when you remove the plug (which houses the pins, and into which the key fits) from the cylinder.

There are also extra top pins, springs and other parts in the kit, but you do not need to be concerned with those now.

(Shown: Keying Kit No. 272 contents)

<p>#1 Master Pin 83106</p>	<p>#2 Master Pin 83110</p>	<p>#3 Master Pin 83112</p>	<p>#4 Master Pin 83113</p>	<p>#5 Master Pin 83114</p>	<p>#6 Master Pin 83125</p>
<p>Knob Plug Retainer 84345</p>	<p>Knob Control Lug (Locking Bar) 87619</p>	<p>Spring 87632</p>	<p>Low Profile Deadbolt Spring Cover 80371</p>	<p>Deadlock Control Lug (Locking Bar) 87609</p>	<p>Deadlock Plug Retainer 84215</p>
<p>Regular Anti-Pick Top Pin 80370</p>	<p>CYLINDER REMOVAL TOOL Cylinder Removal Tool 81467</p> <p>Plug Follower 80152</p>			<p>Key Gauge 80040</p>	<p>PK Anti-Pick Top Pin 80369</p>
<p>Regular Top Pin 81808</p>	<p>PK Balls 82208</p>	<p>Spring Cover (5-Pin) 85757</p>	<p>Tumbler Spring 81777</p>	<p>Spring Cover (6-Pin) 83661</p>	<p>PK Top Pin 83117</p>
<p>#1 Bottom Pin 83100</p>	<p>#2 Bottom Pin 83101</p>	<p>#3 Bottom Pin 83103</p>	<p>#4 Bottom Pin 83105</p>	<p>#5 Bottom Pin 83106</p>	<p>#6 Bottom Pin 83107</p>

How to Gauge a Kwikset Key

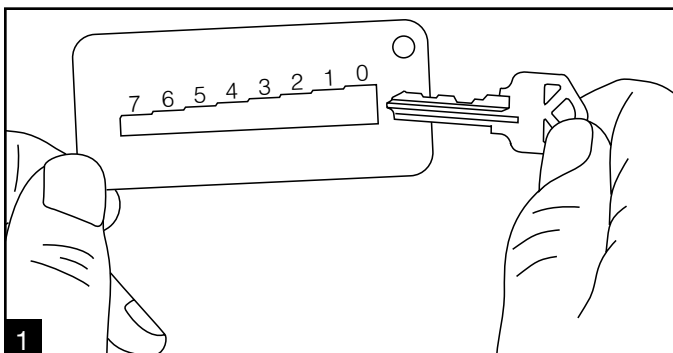

1 Before you can rekey a lock, you have to know what pins to use. For obvious security reasons, Kwikset doesn't print key-cut combinations on the packaging. We use this Key Gauge to find the key-cut combinations. Before disassembling the lock, measure the cuts and write down the numbers.

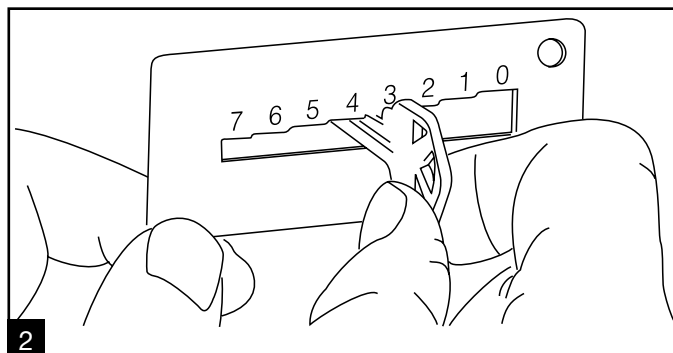

2 Hold the NEW key (the one with which you want this lock to be keyed alike) and slide it into the gauge. ALWAYS gauge a key from the bow (the bow being the part you hold in your fingers) end out. To measure, position the flat portion of the first cut even with the "0" position of the gauge, slide the key toward the narrowing end of the gauge until the key stops at the correct "step". This will always be between two numbers and the cut number is the one to the RIGHT of the key. Here it is a 3.

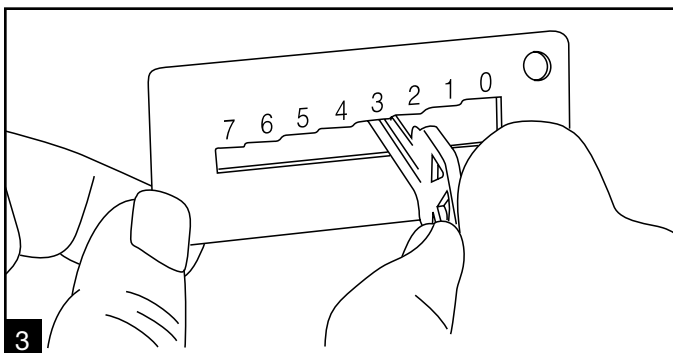

3 Position the next cut and move the key down the gauge until it stops. The second cut of this key is a 2. You can slide the gauge or the key, the result is the same. The first cut comes after the shoulder next to the bow.

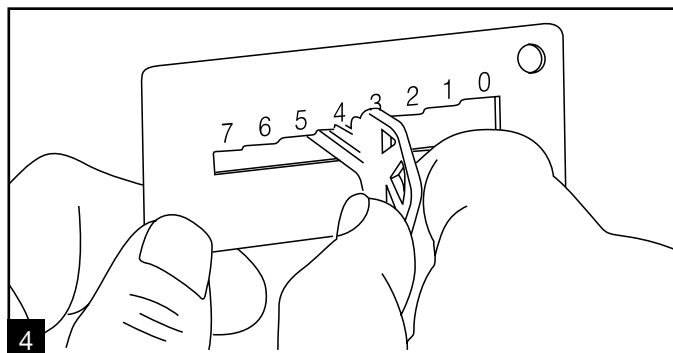

4 Do the same for the third cut which is a 4. Remember, always read the number to the right of the key. Also, remember to read the cuts from the bow of the key out (the bow being the part you hold with your fingers).

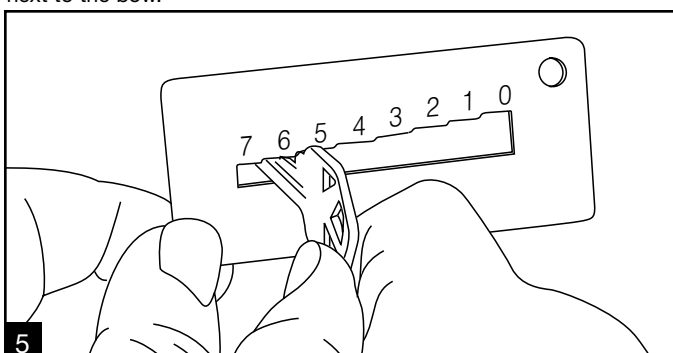

5 It's also a good idea to double-check that you are reading the correct cut each time. In this case, cut number four is a 6.

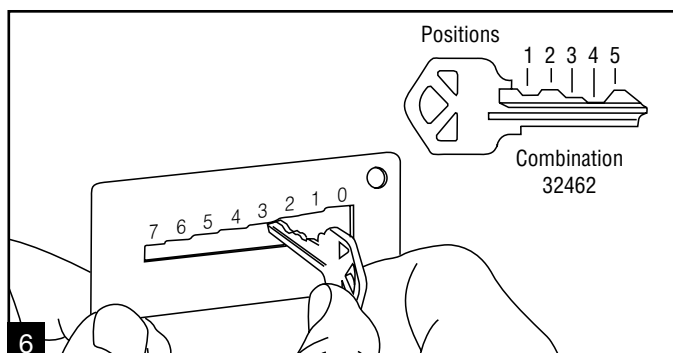

6 Finally, the last cut: a 2. So we have a key with a cut combination of 3-2-4-6-2 (if this is a UltraMax Security key, there will be six cuts to gauge). Of course, you've written that down as you went along. When the time comes, you'll know exactly which pins to select.

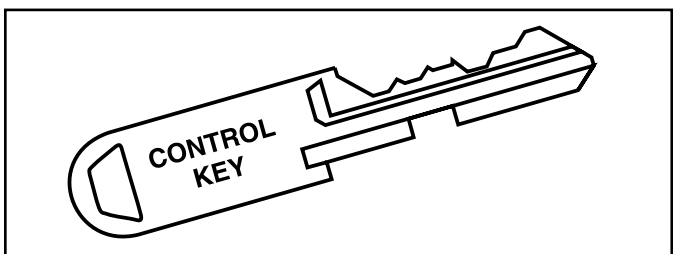

Locate the special "control key" which is cut specifically for the combination of your lock, but with a notch on the bottom of the key blade.

NOTE: If not available, cut a blank "control key" to match existing key.

Key Duplication

Instructions for duplicating cuts from a five pin Kwikset key to a six pin Kwikset or Society Brass key. This permits Kwikset and Society Brass to be keyed alike.

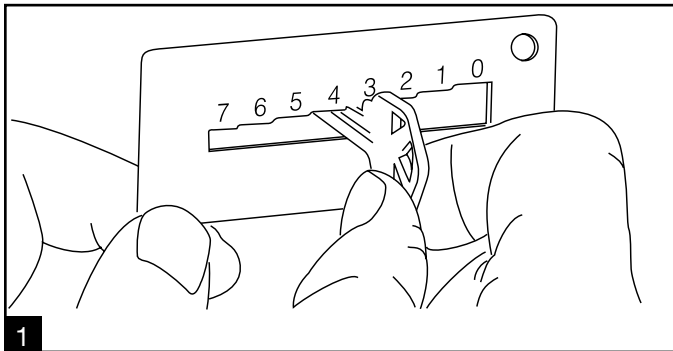

Measure the Kwikset key and write down the key cut combination. These will be the depths required for positions 2 through 6 on the 6 pin key. Save the results for re-pinning the cylinder.

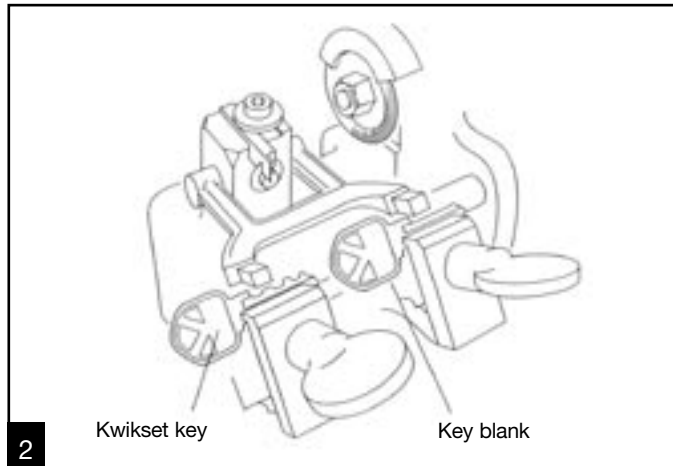

The key duplicator must be of the type that stops against the keys top shoulder. Insert both the Kwikset key and the key blank. Positions 2 through 6 are then cut. Position 1 will be bypassed.

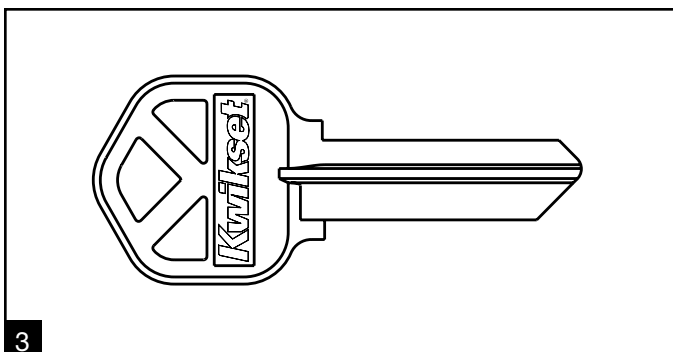

Depth keys are used to duplicate the remaining cut in position 1 of the key. Select depth at random from the 3 keys supplied. Only position 1 has been cut, to prevent contact with any other cut. The cylinder will be pinned to this key cut.

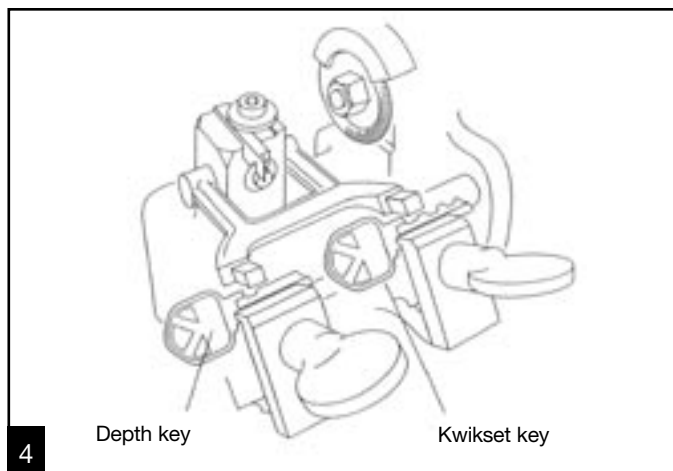

Insert both the depth key and the previously cut key in the key duplicator. Now position 1 of the key is cut to match the depth key. Additional keys may now be duplicated in the usual manner.

Masterkeying

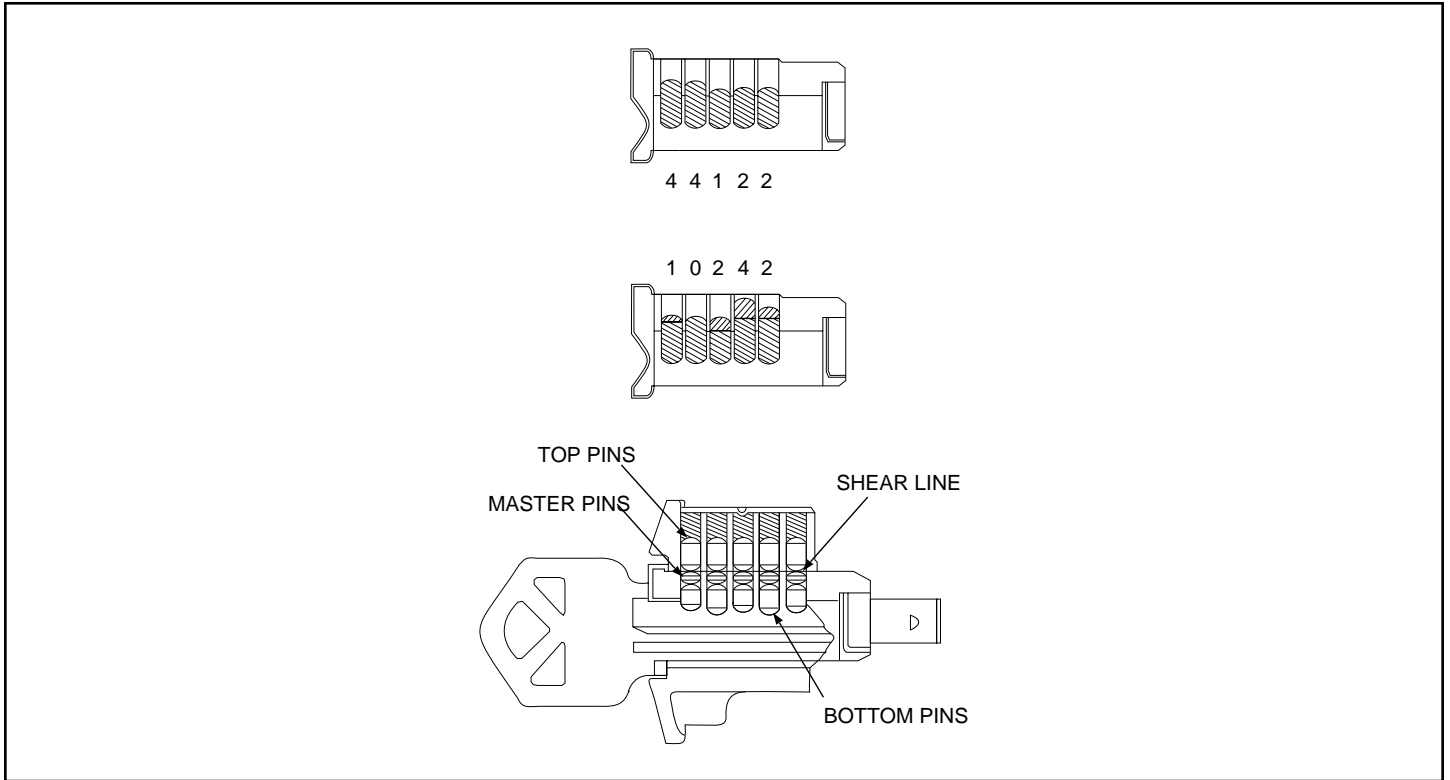

Masterkeying

Masterkeying is making one lock work with two keys. Take two keys - one will be the master key which will be able to open all locks in the complex and the other will be the random key or the tenant's key, which only opens one lock.

- 1 Read both keys. (see Step 1, page 5)

Master Key	5	4	3	2	2
Random Key	4	4	1	6	4

- 2 Circle the smallest number of each cut.

Master Key	5	4	3	②	②
Random Key	④	④	①	6	4

The circled numbers are your bottom pins required.
Drop in the bottom pins without the key in the cylinder.
EXAMPLE - 4 4 1 2 2

- 3 Take the difference of each cut.

Master Key	5	4	3	2	2
Random Key	4	4	1	6	4
	<hr/>	<hr/>	<hr/>	<hr/>	<hr/>
	1	0	2	4	2

The difference (10242) will be the master pins required.
Drop in these master pins on top of the bottom pins without the key in the cylinder. A 0 means that a master pin is not put in that hole.

- 4 Put plug back into the cylinder assembly without key in the plug.

Keying Master Cylinders

Model 740 cylinder is illustrated. Other cylinders are keyed in same manner.

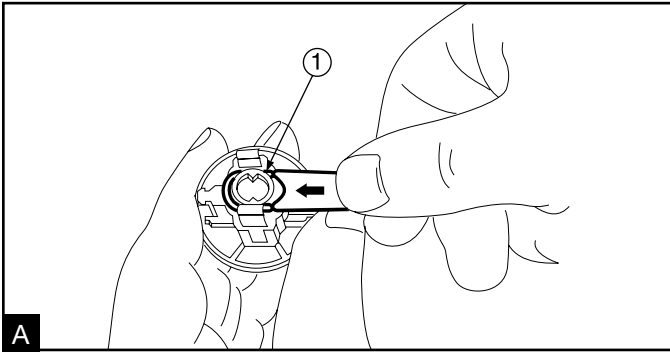

Remove plug clip
Push plug clip (1) off with screwdriver or cylinder removing tool, using a side-to-side motion.

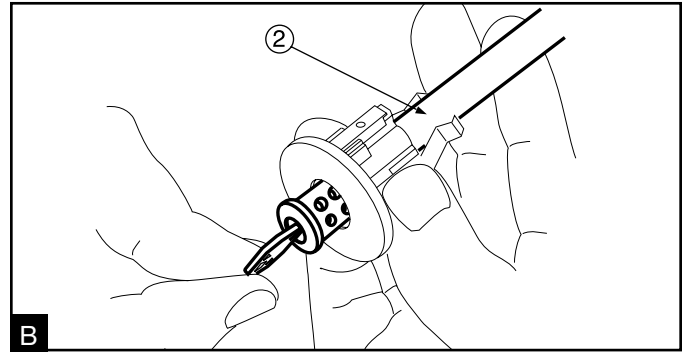

Remove plug
Insert key and turn plug 1/4 turn clockwise. Push plug out of cylinder with plug following tool (2) and leave in cylinder. the plug following tool will keep the top tumbler pins and springs in place.

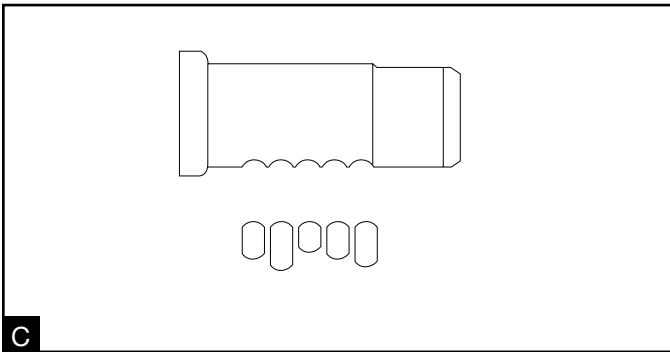

Drop pins out of plug.



Key measurement
Measure cuts of key or keys as illustrated, and write down key cut combinations.

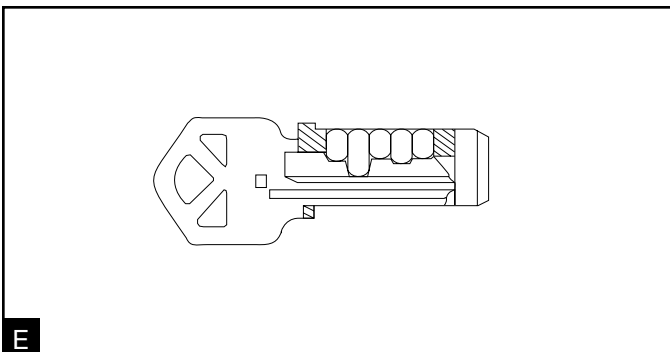

For random keying
Random keying uses only one key. For multiple keys, refer to page 6 (Masterkeying). Insert key into plug. Drop bottom pins into proper holes with pin numbers that match measured depths. Tops of pins should be flush with outside diameter of plug.

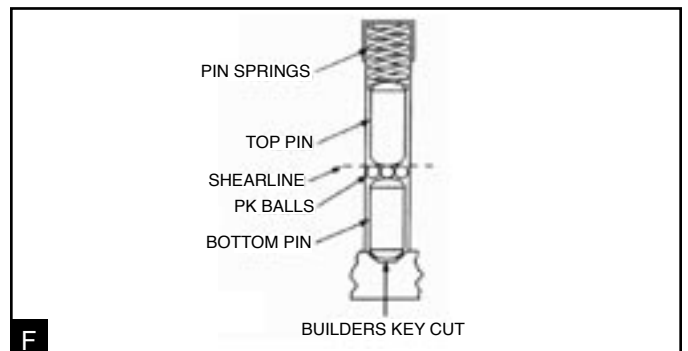

Protecto Keying
Larger kits are capable of Protecto Keying. This is used for new construction and similar to Masterkeying. Use 3 balls in place of a #2 master Pin. Builders key will have a cut two increments deeper than homeowners random key in selected chamber.

Rekeying Knobs

Step-by-step instructions for:
Kwikset Security **Kwikset Maximum SECURITY**

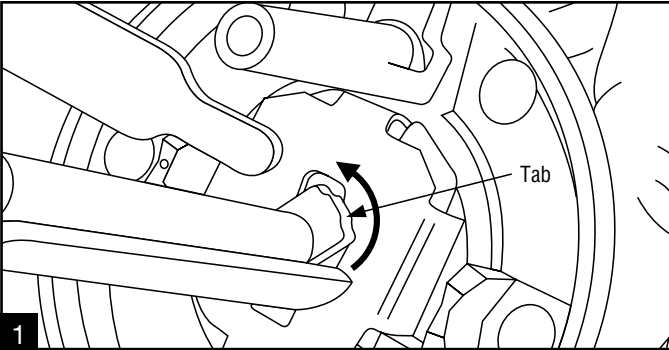

1 Be sure to remove key from cylinder before starting. In order to remove the round spindle, align the tab so it is perpendicular to the bottom of the half-round, as shown at right.

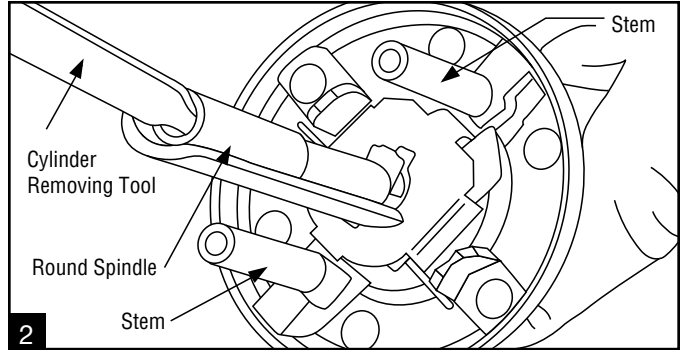

2 Insert the pointed end of the Cylinder Removing Tool into the end of the spindle and turn until the tab is lined up with the stems.

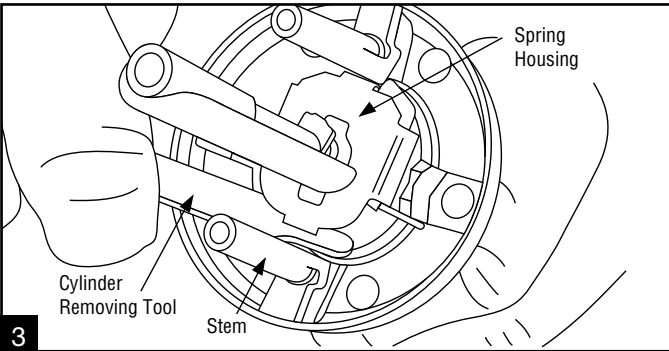

3 Insert small end of the Cylinder removing Tool at an angle against stem, sliding under edge of spring housing. Push in firmly on retainer.

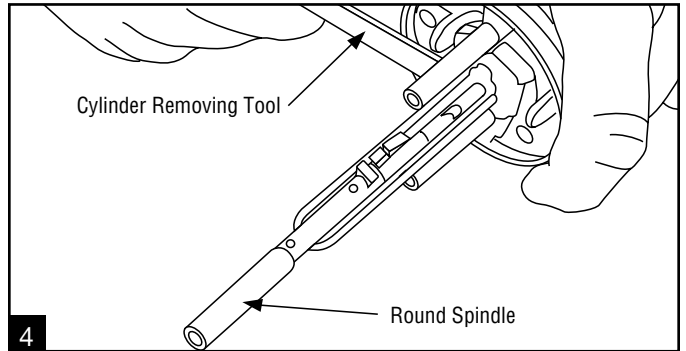

4 Hold the lock with the spindle down and it will fall out. If not, keep pressing with the tool and use your thumb to slide the round spindle out.
If the round spindle rotates, you will need to repeat steps 1 - 4.

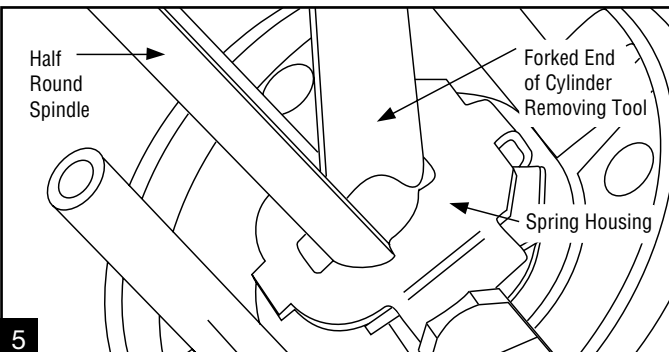

5 To remove the cylinder, place the forked end of the tool down the half-round spindle through spring housing. You'll see a hole there, and you have to fit the forked end of the Cylinder Removing Tool under the top of that hole and pry it open.

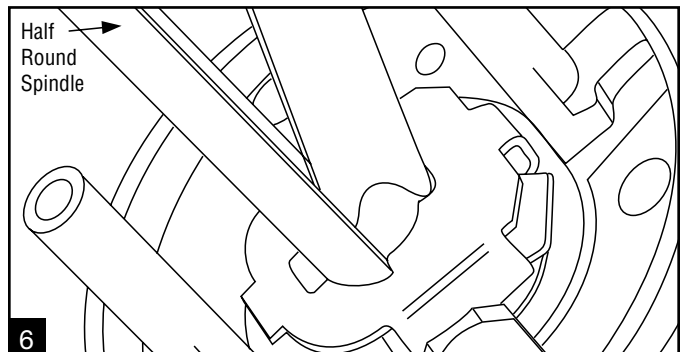

6 Once you have "opened" the spring housing, slide the tool all the way in until it stops. Be firm, but not forceful. Keep the Cylinder Removing Tool perpendicular to the half-round spindle at all times.

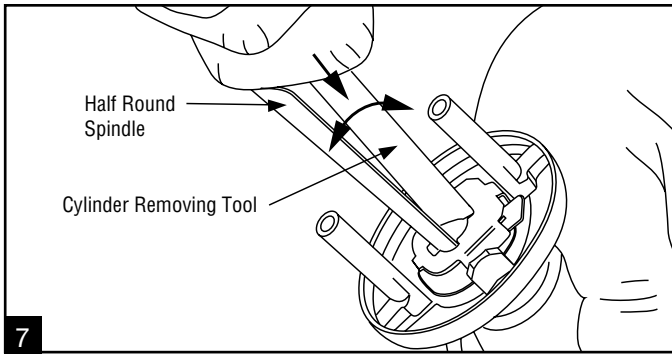

With the Cylinder Removing Tool all the way in, put your other hand over the outside of the knob, covering the cylinder and plug.

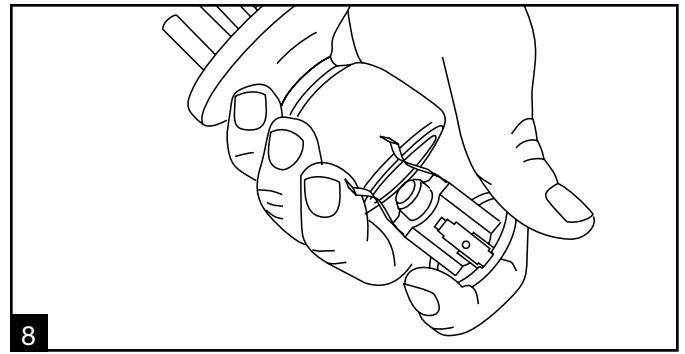

The cylinder will come right out in your hand. For most, this is the most difficult part of rekeying. It takes practice to get the tool in under the spring housing, and getting just the right motion and pressure to pop the cylinder loose.

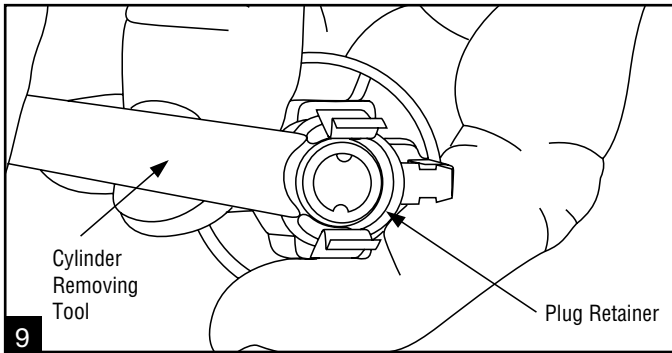

Use the forked end of the Cylinder Removing Tool to disengage plug retainer.

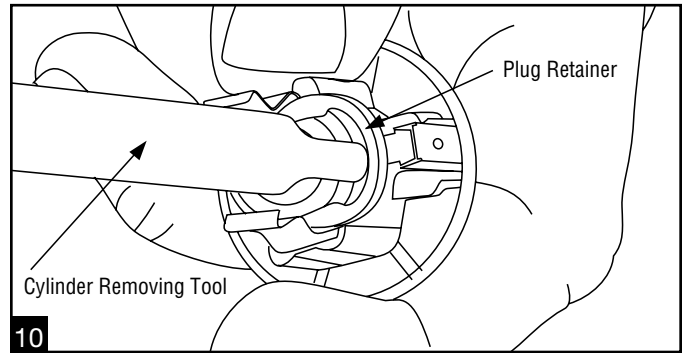

Then use the small end to free it completely. Use care not to deform plug retainer.

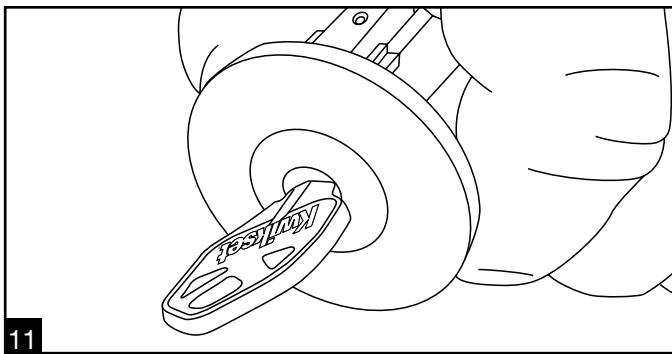

Slide the EXISTING key for this lock into the keyway and turn the key about 45° to the right or left. Keep key at this angle for next step. **Be sure not to let key cylinder slide out.**

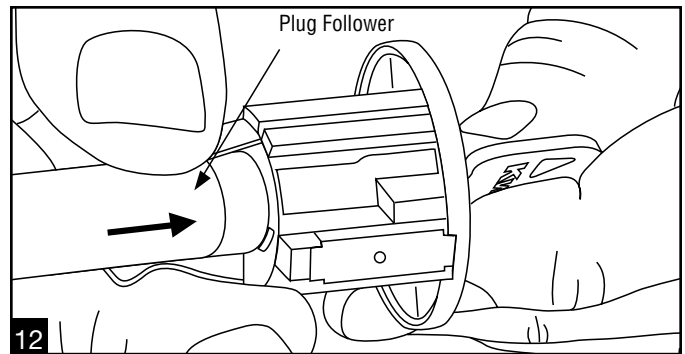

Still holding the plug firmly in the cylinder, use the **flat end** of the plug follower (the notched end is for a different kind of cylinder) to PUSH the plug out gently and evenly from the rear. Push it steadily, do not pull the plug.

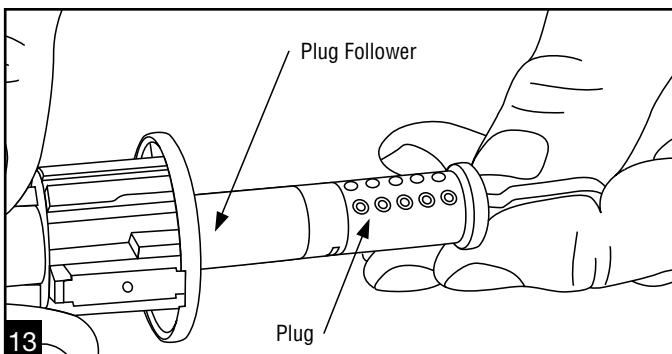

Keep pushing until the tool sticks out at least an inch. **Leave it in place until you reassemble.** Carefully remove the plug, holding it by the key and don't turn it.

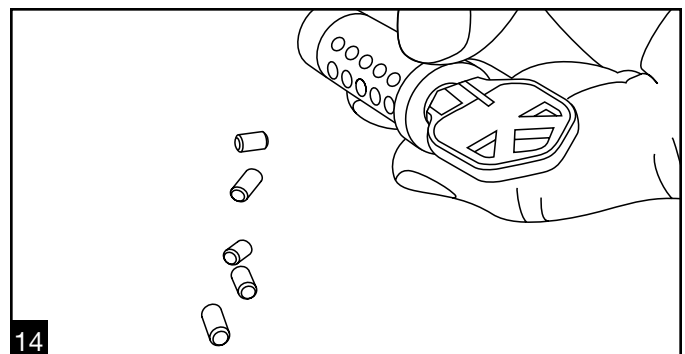

Now you can see the bottom pins in the plug. Turn it over to dump them out and discard them. It's not worth the time and possible sorting errors to restock them.

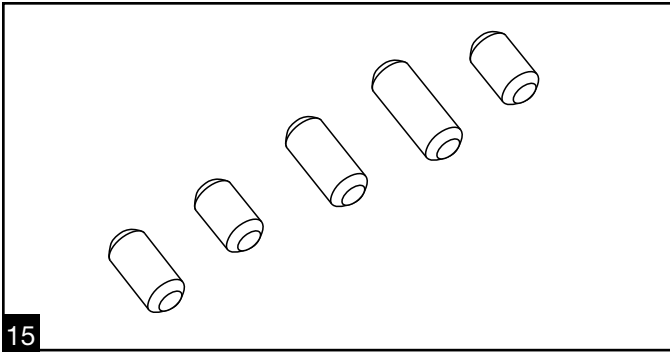

15
 Checking the key bitting (combination) you gauged earlier, you'll select the pins which match those cuts from the appropriate compartments in the Rekeying Kit. Example: 3-2-4-6-2. A No. 3 bottom pin to a No. 3 key cut depth, a No. 2 to a No. 2, etc.

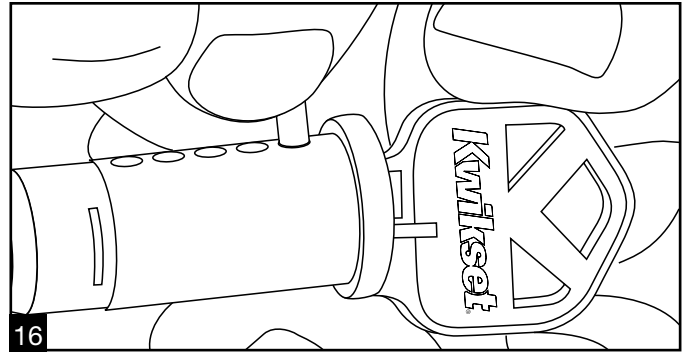

16
 Put the new key into the plug and, working from the bow (front) end of the plug, drop the first pin into its chamber – here a No. 3. Some people find using their fingers easier, others prefer tweezers. Either way, it takes some patience to deal with these tiny pins.

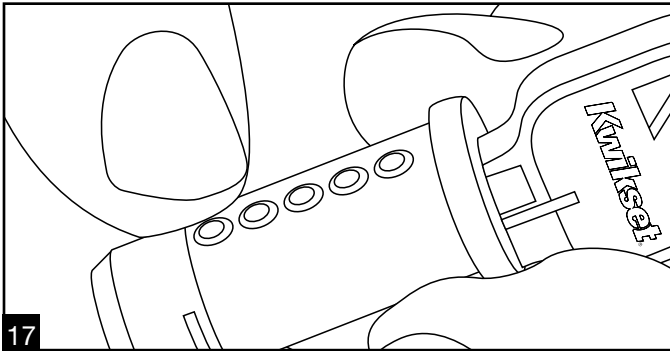

17
 Install pins one by one, from the front (bow) to the back (tip) and be sure they are all flush with the top surface of the plug. A pin which is too long will prevent plug insertion with the key installed. A pin which is too short will cause the lock to malfunction.

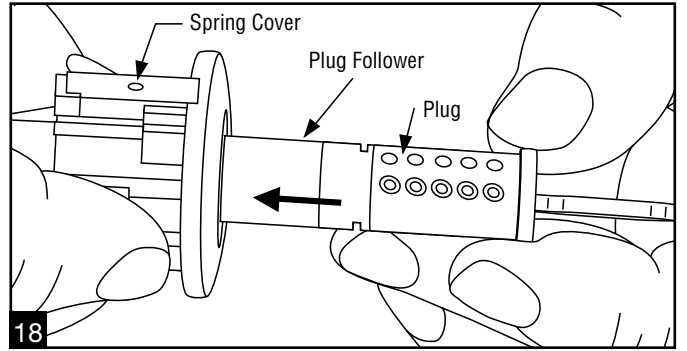

18
 Now all you have to do is reassemble the plug into the cylinder housing in exactly the reverse order. Start by placing the end of the plug against the end of the plug follower. Again, turn the key so it is about 45° to the right or left of the spring cover. Then slowly and smoothly PUSH the plug follower back into the cylinder with the plug.

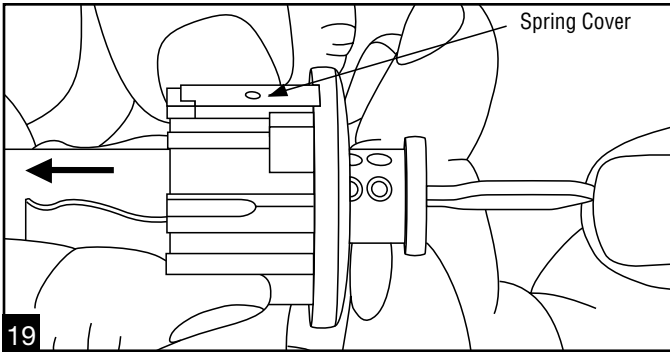

19
 When it's all the way in the cylinder, turn the key so it is in line with the spring cover on top of the cylinder. You're done with the plug follower, but hold the plug and cylinder firmly together.

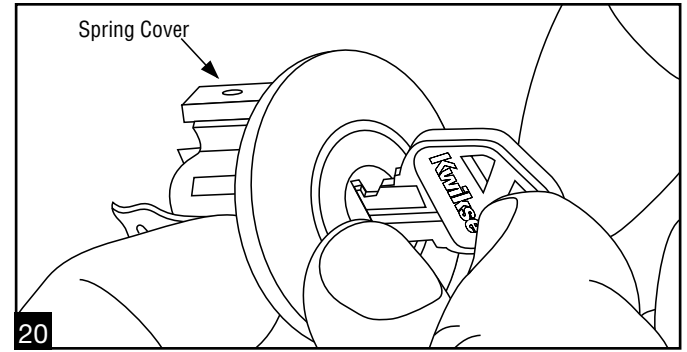

20
 This is important. Hold the plug all the way into the cylinder with your thumb. Making sure the key is still in line with the pin cover, pull out the key. Keep pressure on the plug until the key is out.

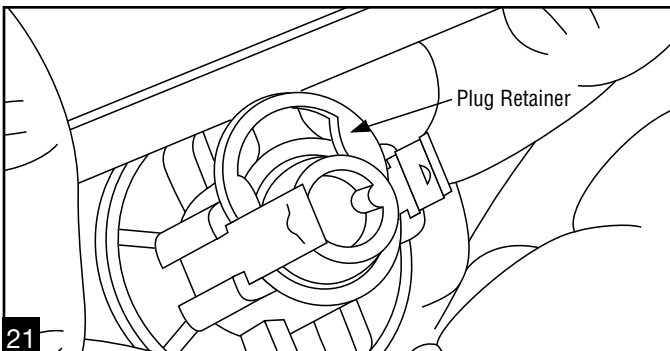

21
 Put the plug retainer back in from the side of the spring cylinder as shown and use the Cylinder Removing Tool to snap it back into place. Be sure the inside edges of the retainer line up with grooves in the plug.

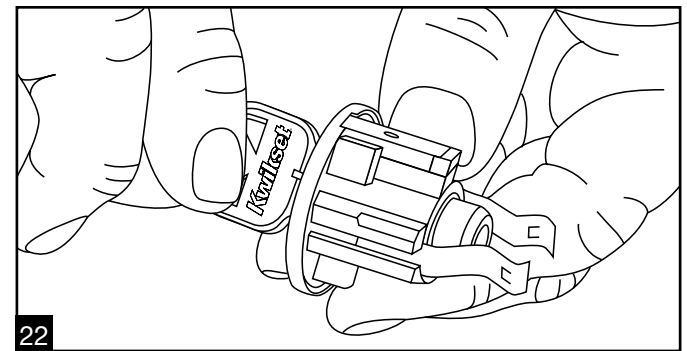

22
 Insert the key and turn it back to the vertical position, in line with the spring cover on top of the cylinder.

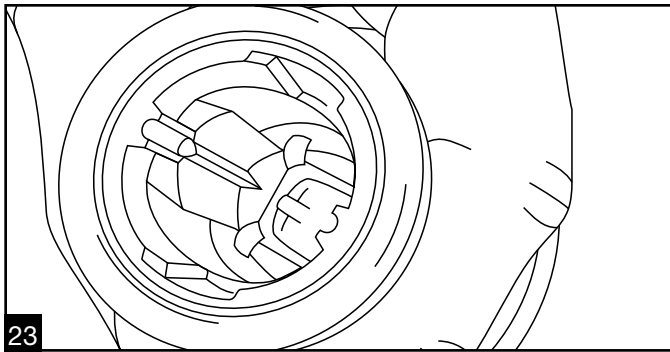

23

Observe the wide channels top and bottom inside the knob cavity and the spring cover on top of the cylinder. Correct orientation of the knob, will depend of the handing of the doorway. With the curved side of the half-round toward your body, align the pin cover with the top channel in the knob cavity.

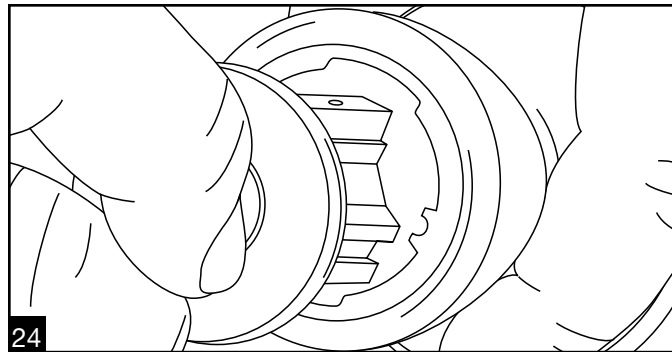

24

Keeping the spring cover aligned with the top channel, push the cylinder all the way into the knob until you hear the spring retainers snap into place.

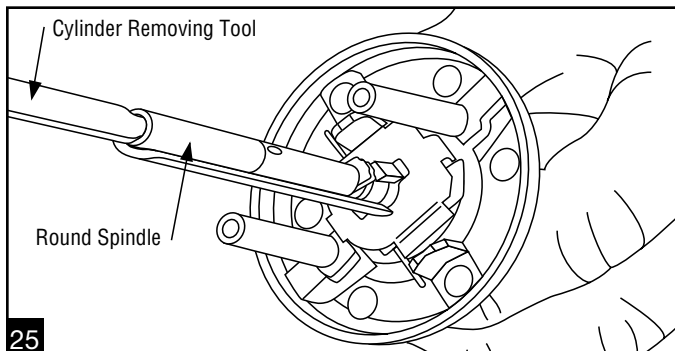

25

Remove key from the cylinder. Then slide the round spindle tab-end first and tab up, into the half-round spindle and push it in until it clicks.

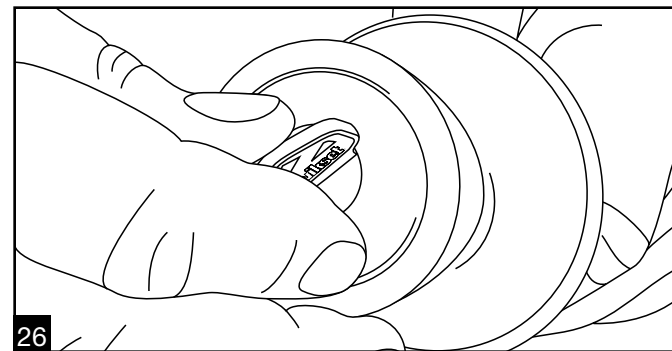

26

Reinsert the key into the cylinder. Hold assembly by the stems and work the key back and forth a few times to make sure everything is in proper order.

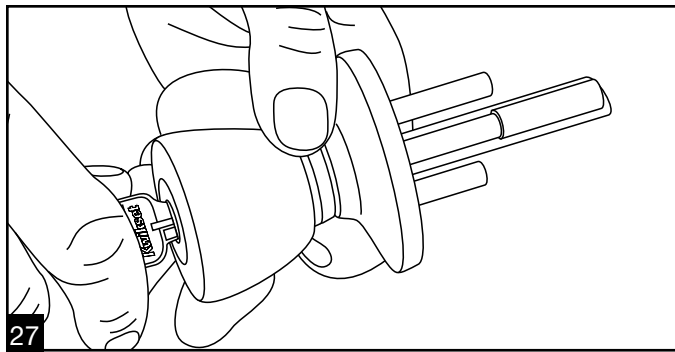

27

You have rekeyed a Kwikset lockset!

Rekeying Laurel Eggknob

Step-by-step instructions for:

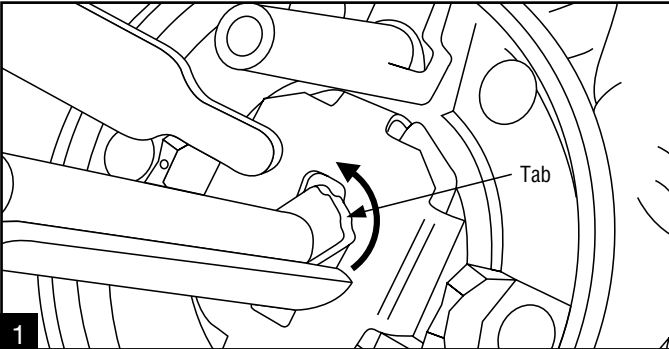
1 Be sure to remove key from cylinder before starting. In order to remove the round spindle, align the tab so it is perpendicular to the bottom of the half-round, as shown at right.

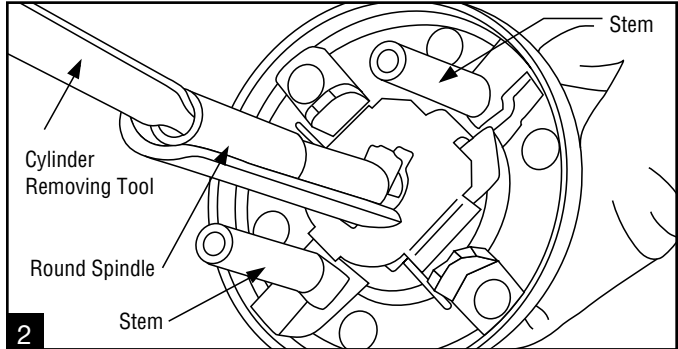

2 Insert the pointed end of the Cylinder Removing Tool into the end of the spindle and turn until the tab is lined up with the stems.

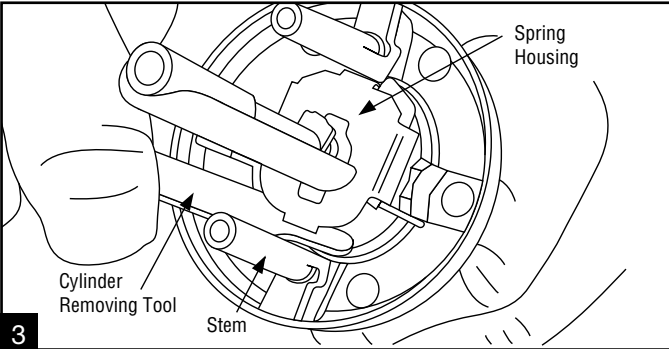

3 Insert small end of tool at an angle against stem, sliding under edge of spring housing. Push in firmly on retainer.

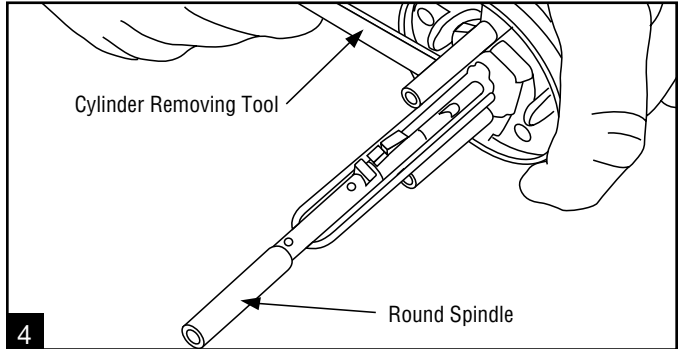

4 Hold the lock with the spindle down and it will fall out. If not, keep pressing with the tool and use your thumb to slide the round spindle out.

If the round spindle rotates, you will need to repeat steps 1

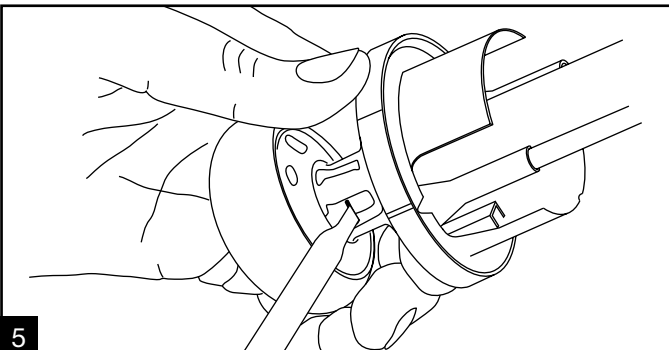

5 Depress the lever catch and pull keyed portion from the chassis.

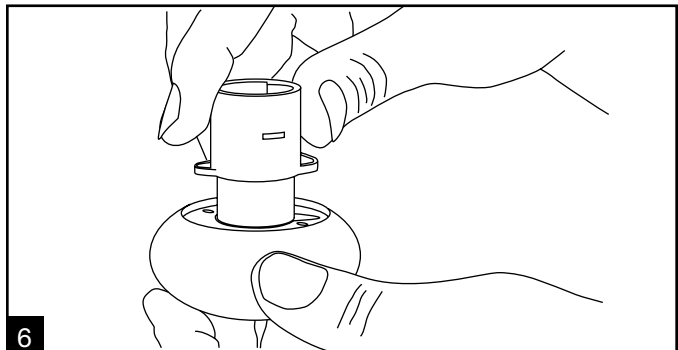

6 Pull off knob cover (shank).

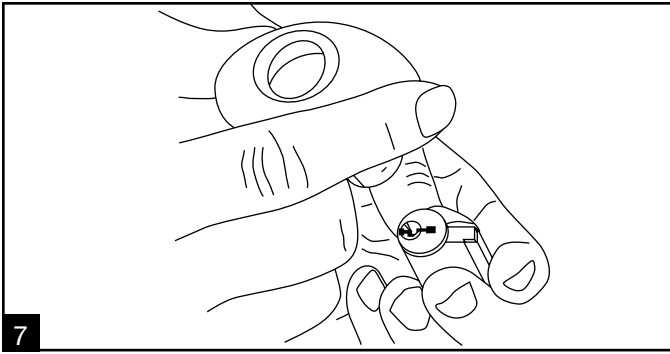

7 Turn knob over and the cylinder will fall out into your hands. At this point, you are able to re-key the cylinder.

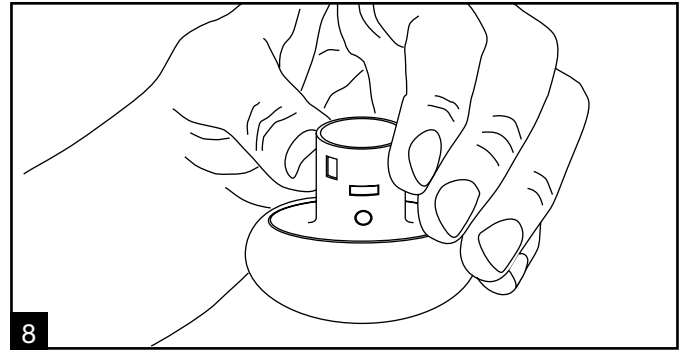

8 After re-keying the cylinder, return it to its original position, while holding the keyed portion toward the floor.

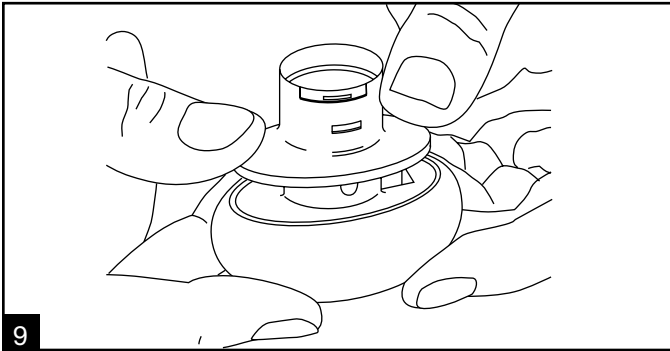

9 Replace the knob cover. (note: it goes on either way) Make sure that it has a snug fit to avoid any possible "knob wobble".

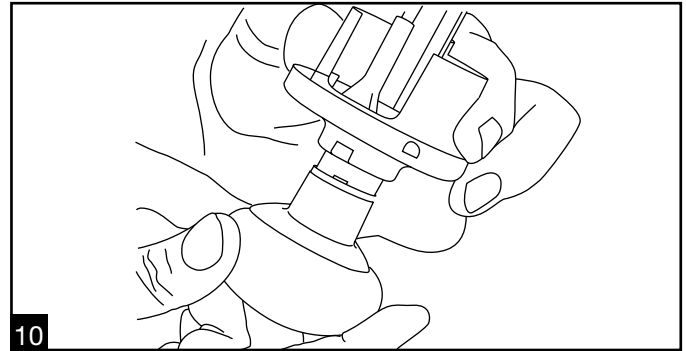

10 Attach keyed portion to the chassis. Make sure that you hear the lever catch engage. Pull on the keyed portion to the chassis. Make sure that you hear the lever catch engage. Pull on the keyed portion to be sure that it is properly re-assembled.

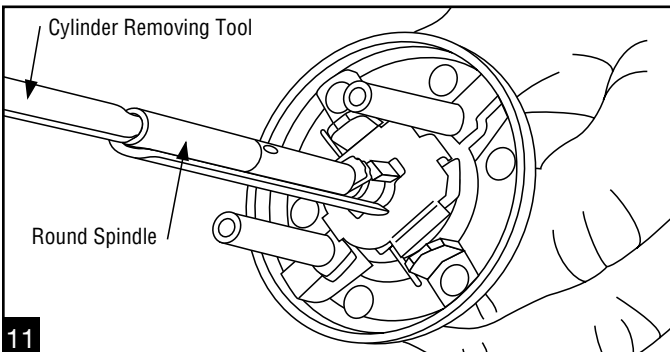

11 **Remove key from the cylinder.** Then slide the round spindle tab-end first and tab up, into the half-round spindle and push it in until it clicks.

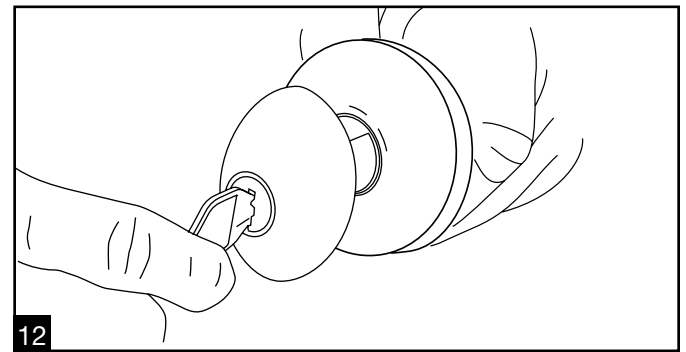

12 Reinsert the key into the cylinder. Hold assembly by the stems and work the key back and forth a few times to make sure everything is in proper order.

Rekeying Knobs with a control key



If no control key exists, use the customer's existing key to cut one. When making the new key, also make a new control key with the same bitting (combination) as the new key.

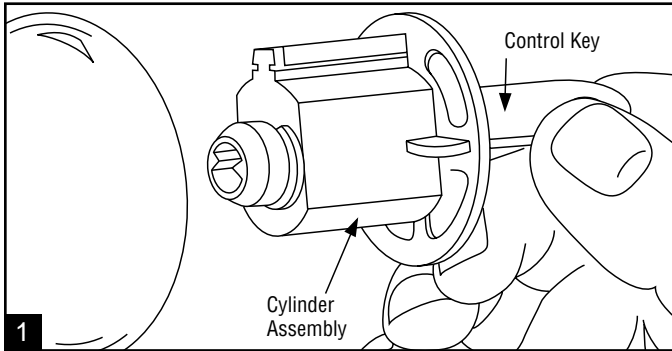

Insert control key, turn 90° (1/4 turn) counterclockwise and pull out core. Remove control key from core. Failure to do this could allow plug to come out of the cylinder shell dropping pins and springs.

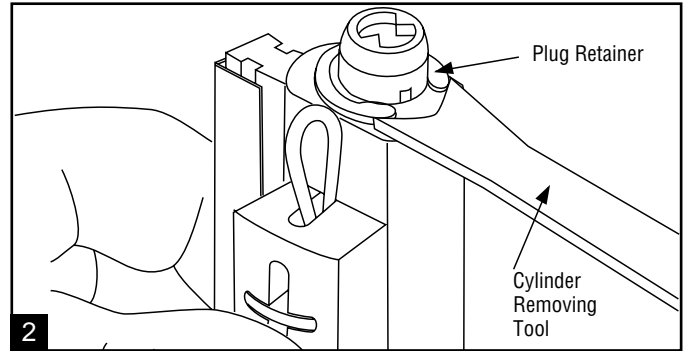

Fit forked end of Cylinder Removing Tool into open end of plug retainer and push it out (use screwdriver if tool is not available).

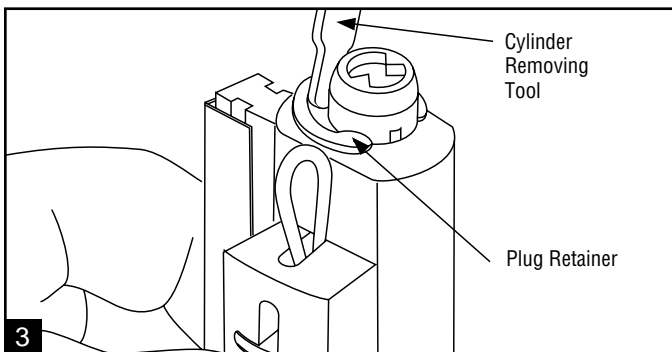

Move the plug retainer out the rest of the way with the other end of the Cylinder Removing Tool (or small screwdriver). **Use care not to deform retainer.**

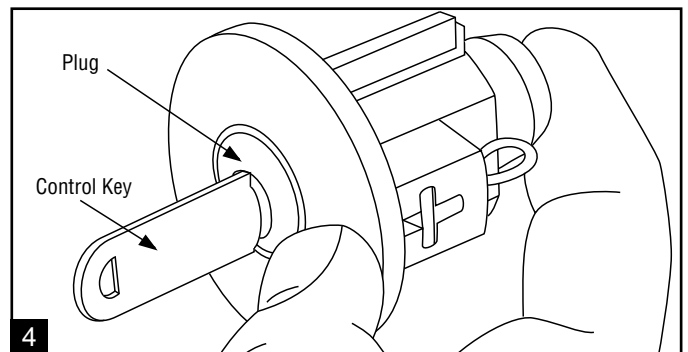

Reinsert old control key. Use thumb to hold key or plug in place. (With the plug retainer off, the plug could slide out, dropping pins and springs.)

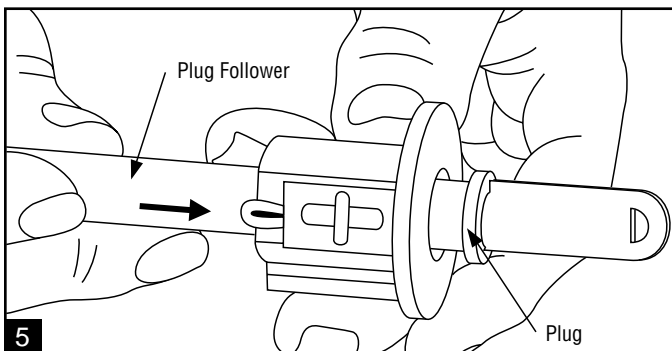

Rotate plug slightly clockwise or counter-clockwise. Using the follower, push the plug out from the back. Make sure the follower stays tight against the plug or the top pins and springs will fall out. (See page 19 if this happens.) Make sure the plug follower sticks out at least one inch. **Leave it in place until you reassemble.**

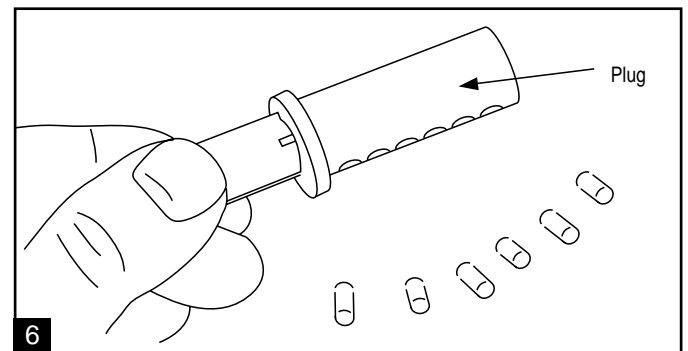

Drop out the old pins, remove the old control key and insert the new control key. (We will assume you have already gauged the new control key.)

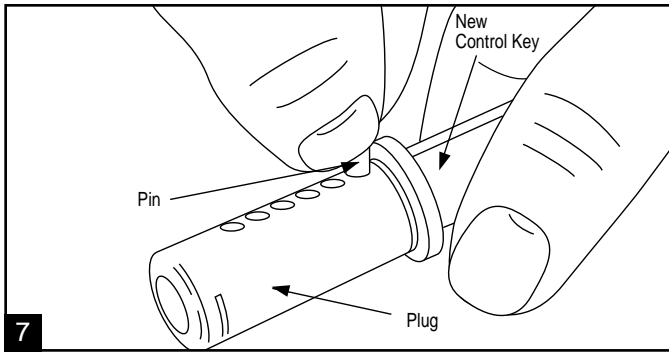

Begin inserting the new bottom pins from the appropriate compartments in the rekeying kit according to the bitting of the new key. You may handle the bottom pins with tweezers or your fingertips.

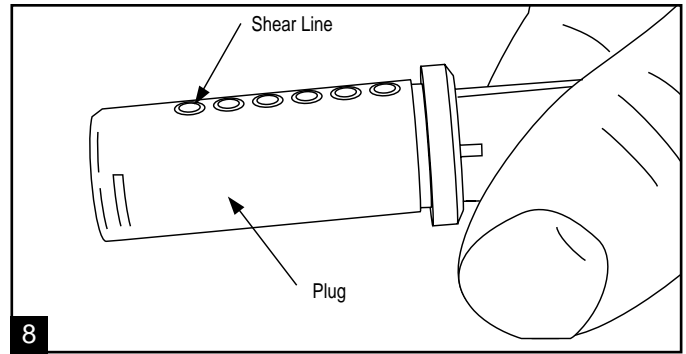

If all the bottom pins are the proper size for the key, they will create the shear line. **Check this carefully.** A pin which is too long will prevent insertion of the plug while the key is inserted. A pin which is too short will allow the cylinder to lock up with no key operation.

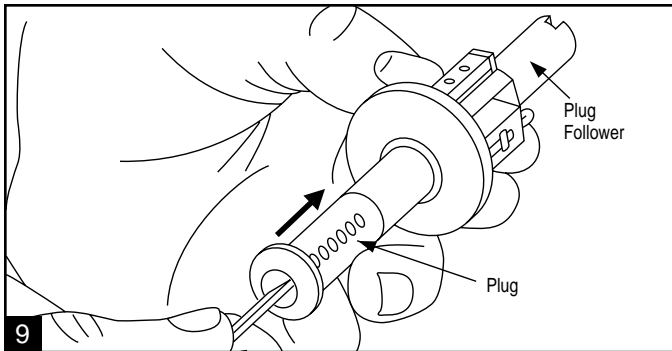

Start reassembly in the same manner you began. Use the plug to push the follower back through the cylinder. Hold the plug firmly into the cylinder with your thumb and turn the control key straight up and remove it.

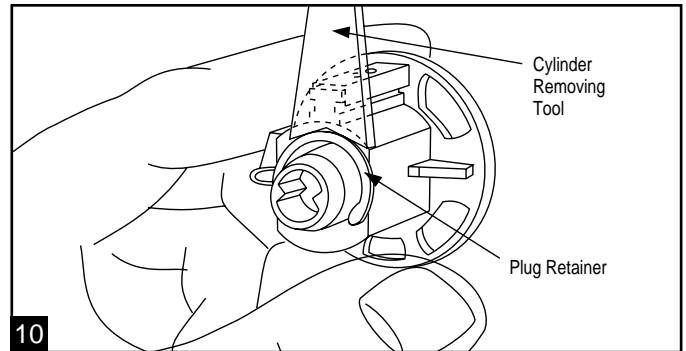

Use the cylinder removal tool to reset the plug retainer. Test cylinder with key to make sure it turns properly.

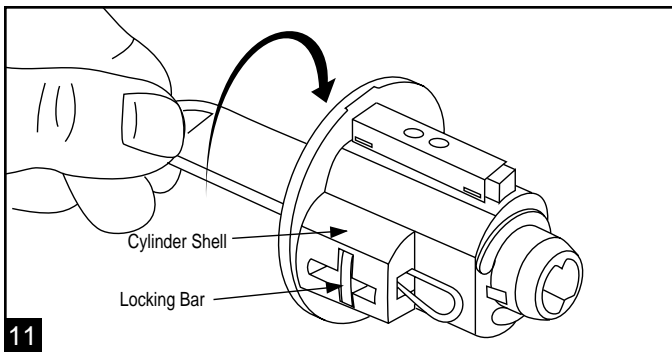

Insert and rotate control key 90° (1/4 turn) counterclockwise. Locking bar must be flush with the surface of the shell for insertion into knob.

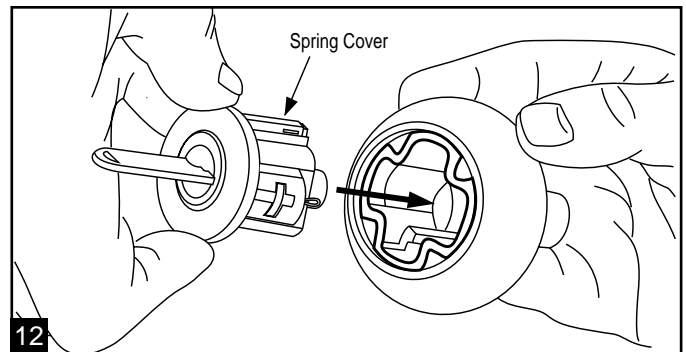

Insert core into knob with spring cover up (do not install upside down) if lockset is not on door.

NOTE: Correct orientation depends on the hand of the door where the lock is to be installed.

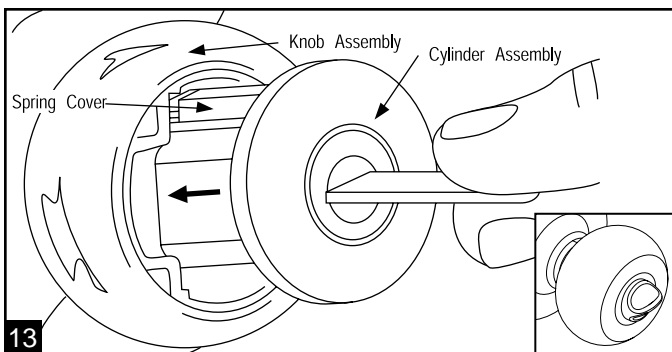

Insert core into knob. Make sure that the spring cover is in the up position.

Note: Interior turnbutton must be in the unlocked position.

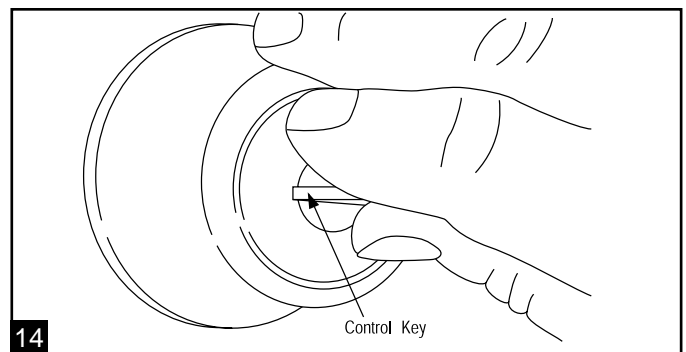

Rotate control key 90° (1/4 turn) clockwise to vertical position and remove. Check with standard operating key for proper operation.

Rekeying Knobs with a standard operating key but without a control key



If you can cut a control key to match the existing key, the process is much easier.

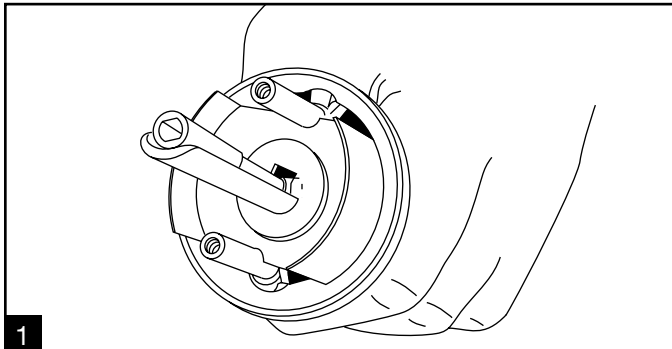

1 Remove lockset from door.

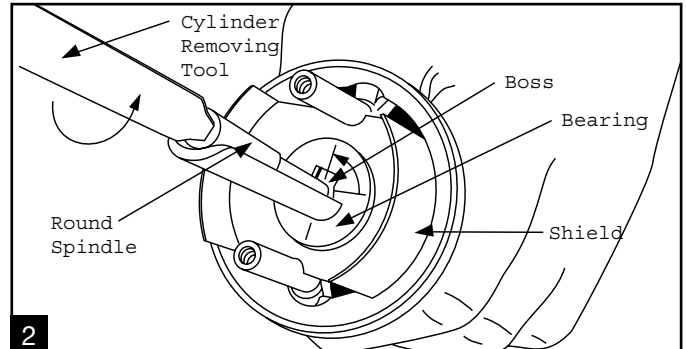

2 Pull the shield off far enough to allow access to the mechanism at the base of the spindle. Rotate the round spindle with the Cylinder Removing Tool (or small screwdriver) to line up the boss of the spindle with the slot of the plastic bearing.

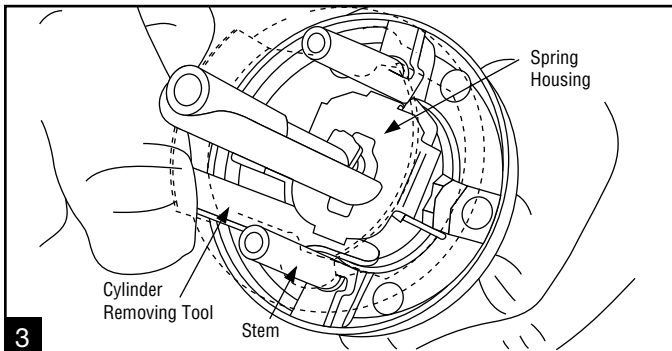

3 Insert the same end of the cylinder removal tool between the screw stem and the detent slide. Apply slight force by pressing against detent slide to remove spring tension while holding spindle downward allowing spindle to drop out. If necessary, use free finger to assist spindle removal. If spindle rotates, repeat step (2).

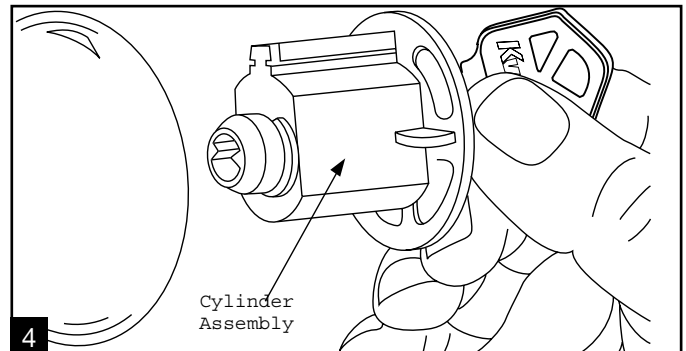

4 Turn key 180° (1/2 turn) counterclockwise and pull out cylinder.
CAUTION: Turn the key back and remove it. Failure to do this may allow the plug to come out, dropping pins and springs if plug retainer is removed first.

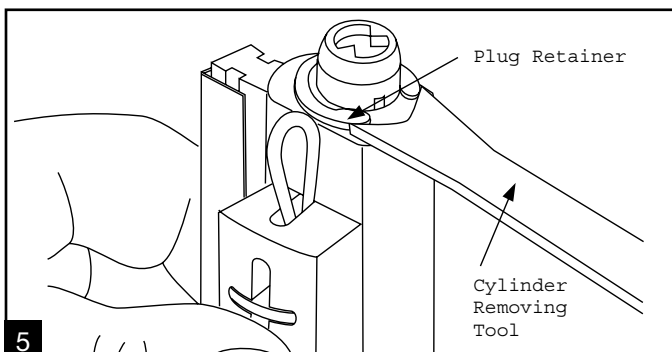

5 Fit forked end of Cylinder Removing Tool into open end of plug retainer and push it out (use screwdriver if tool is not available).

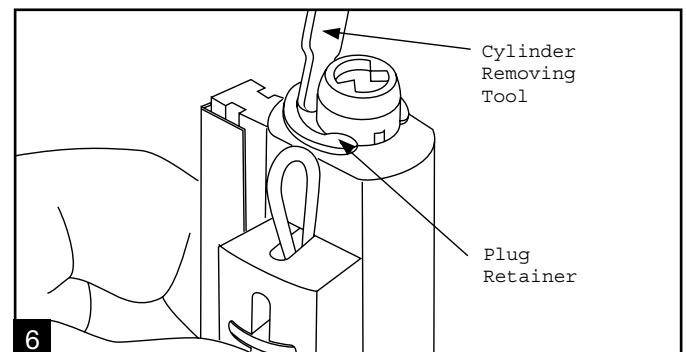

6 Remove the retainer completely using the other end of the tool (or small screwdriver).
NOTE: Use care not to deform plug retainer.

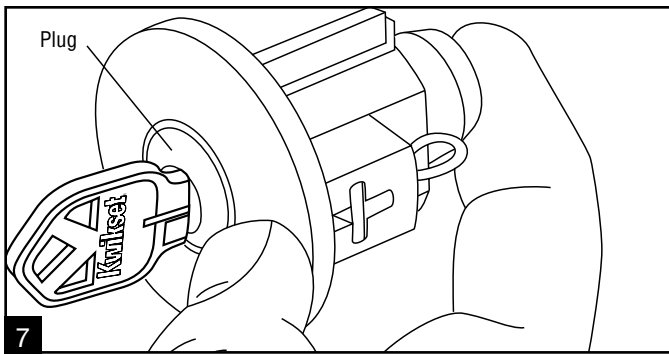

7 Reinsert old key. Use thumb to hold key or plug in place.

CAUTION: With the plug retainer off, the plug could slide out, dropping the pins and springs.

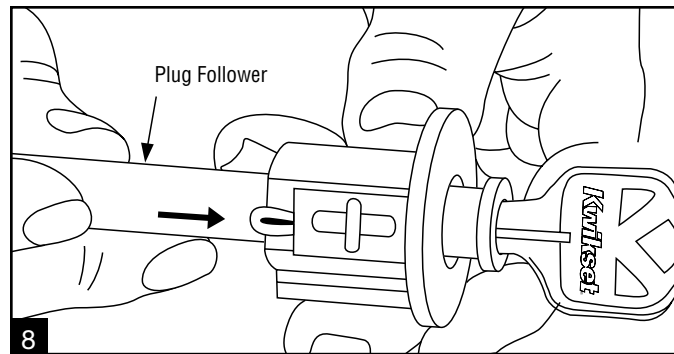

8 Use the plug follower to push the plug out from the back. Make sure it stays tight against the back of the plug or the top pins and springs will fall out. (See page 19 if this happens.)

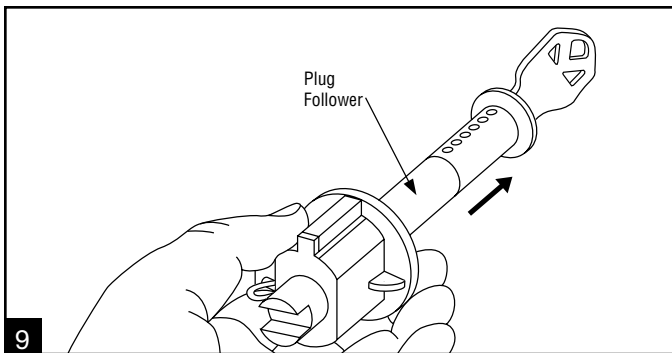

9 Make sure the follower sticks out at least one inch. **Leave it in place until you reassemble.**

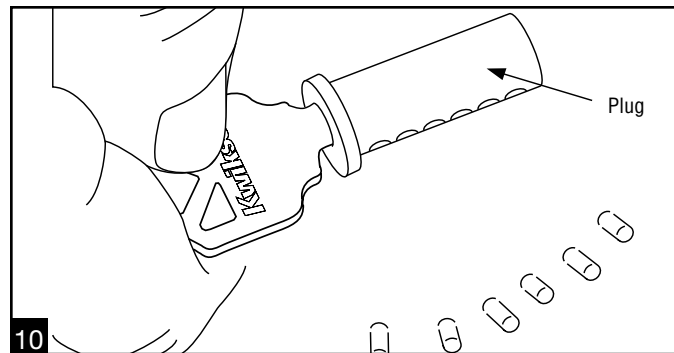

10 Drop out the old pins, remove the old key and insert the new key. (We will assume you have already gauged the new key.)

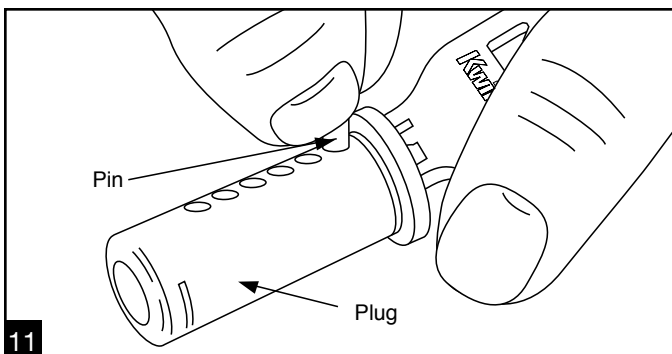

11 Begin inserting the new pins from the appropriate compartments in the rekeying kit according to the bitting (combination) of the new key. You may handle the bottom pins with tweezers or your fingertips.

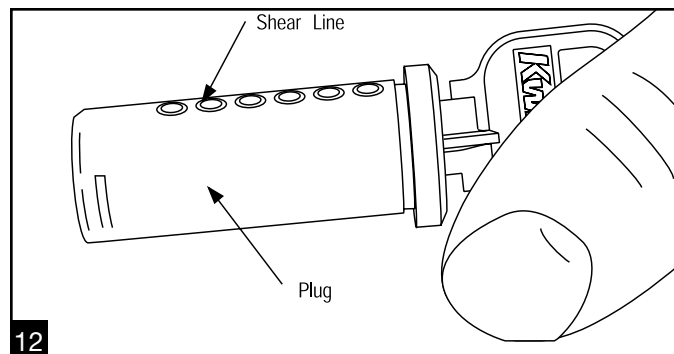

12 If all the bottom pins are the proper size for the key, they will create the shear line. **Check this carefully.** A pin which is too long will prevent insertion of the plug while the key is inserted. A pin which is too short will allow the cylinder to lock up with no key operation!

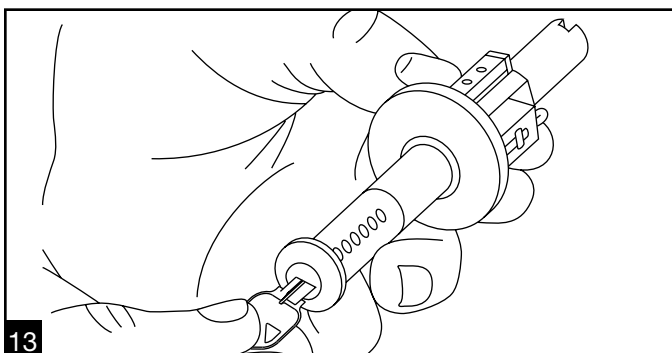

13 Start reassembly in the same manner you began. Use the plug to push the follower back through the cylinder.

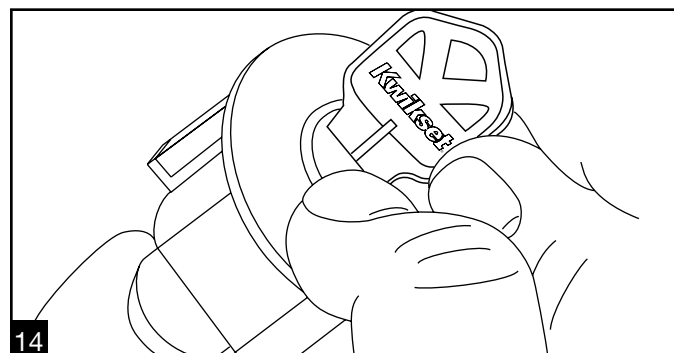

14 Holding the plug firmly in the cylinder with your thumb, turn the key straight up and remove it.

CAUTION: Do not allow the plug to come out as you remove the key!

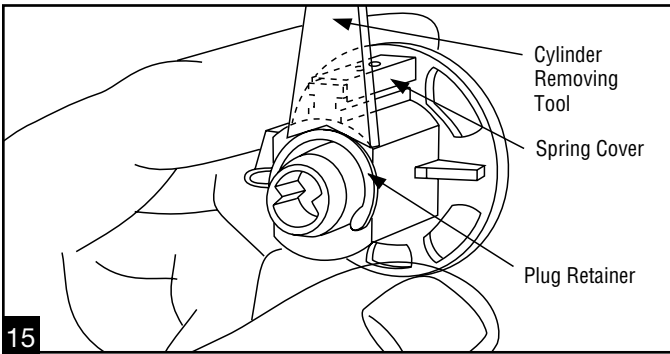

15 Use the cylinder removing tool to reseal the plug retainer. Test cylinder with key to make sure it turns properly.

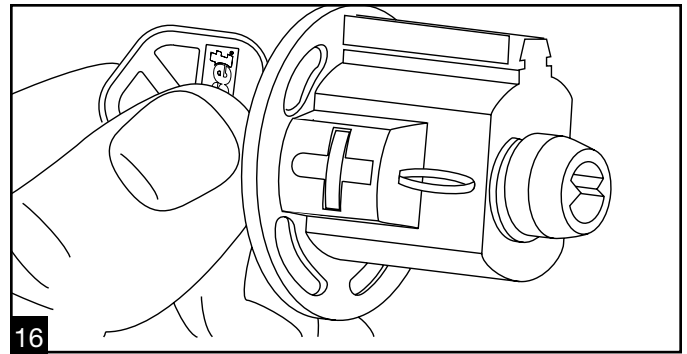

16 Insert key and turn 180° (1/2 turn). The cylinder can be installed into the knob two ways. To be sure it will be right side up when the lockset is installed, you must determine the hand of the door before installing the cylinder.

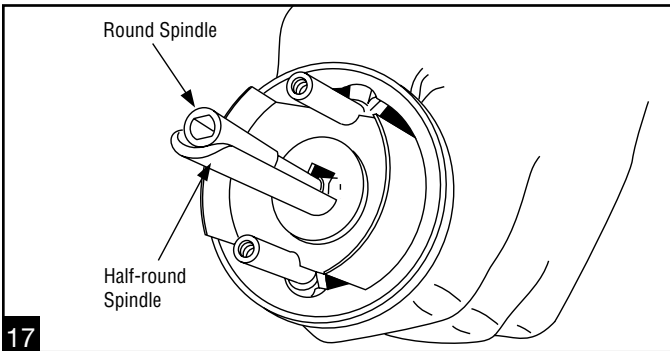

17 Notice C-shaped outer spindle protruding behind knob. Orientation of the lockset on the door is determined by this piece.

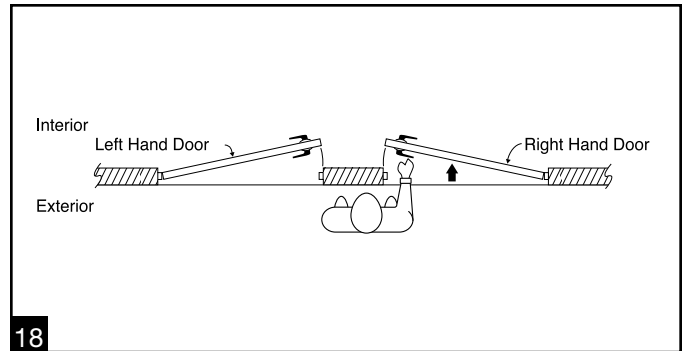

18 Picture the door from the keyed side (normally the outside) and determine whether the hinges are on the right or left. The knob assembly will be right side up when the open side of the C-shaped spindle faces the hinges and the smooth curved side faces the free edge of the door.

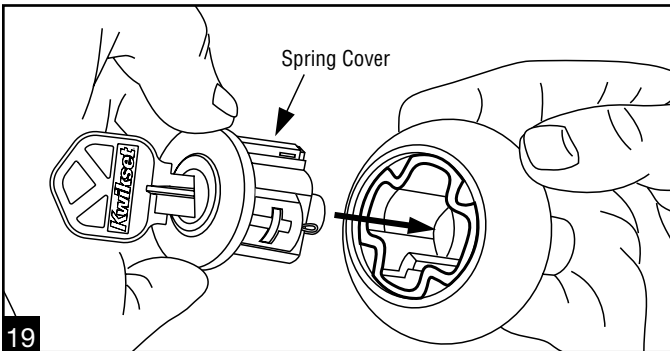

19 Hold the knob assembly right side up for its eventual installation. Align the cylinder spring cover with the top of the knob and install the cylinder.

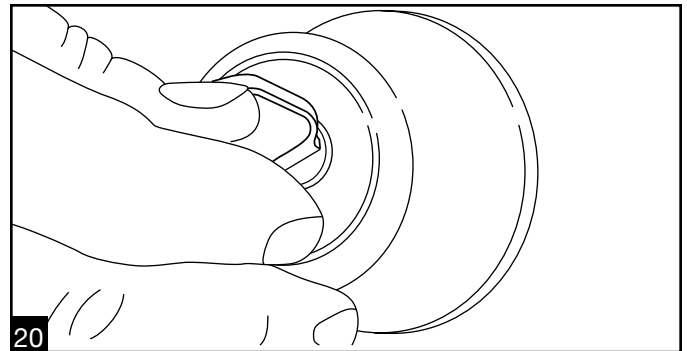

20 Turn the key 180° (1/2 turn) and remove key.

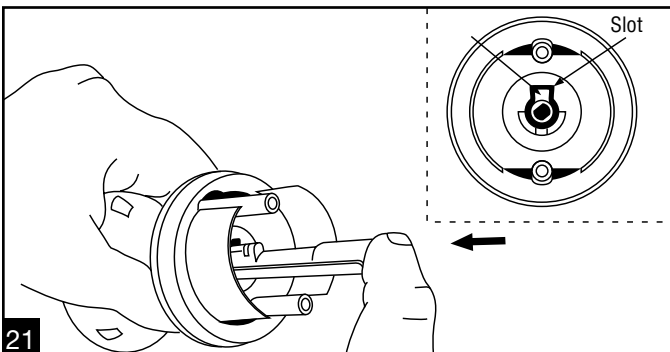

21 Replace the round inner spindle by lining up boss with slot. Push spindle until it snaps into place. Reseat shield and plastic bearing.

Step-by-step instructions for:

Kwikset
UltraMax
SECURITY

Rekeying Knobs

What to do if the top pins and springs drop out during rekeying

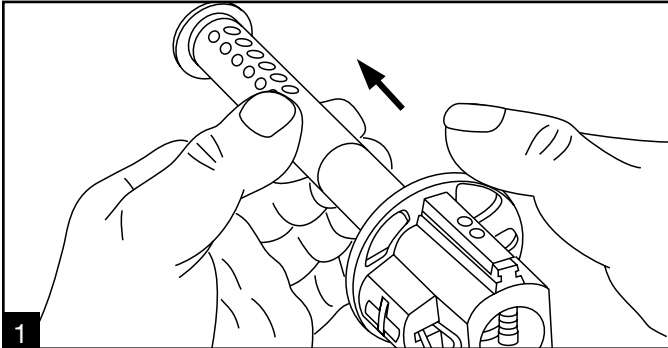

Pull out the plug and plug follower allowing all pins and springs to fall out of the cylinder.

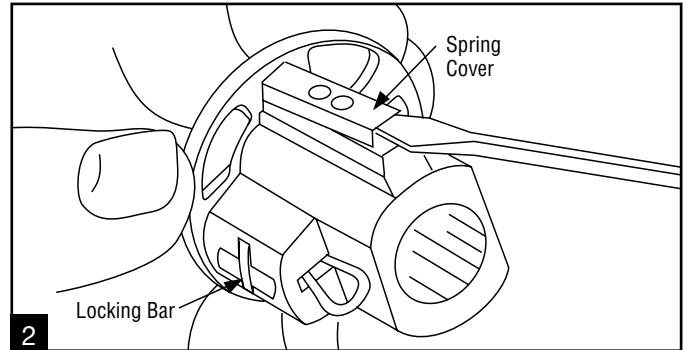

Carefully pry off spring cover with small screwdriver. Removal of the locking bar is not necessary. When you reach the point to reinsert the plug into the cylinder housing, depress the locking bar from the inside of the cylinder housing with a small screwdriver while inserting the plug.

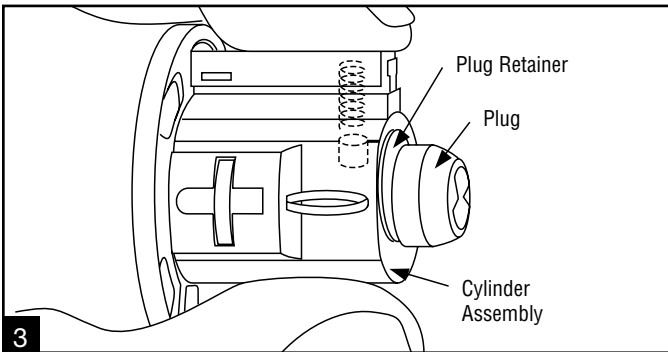

After plug is rekeyed per the instructions, insert into cylinder shell. Install plug retainer. Replace all top pins and springs (they are all the same). Carefully push spring cover on. If you have removed the locking bar and spring, replace them at this time. Place locking bar in slot. Rotate key until locking bar is flush with cylinder shell. Secure with locking bar spring. Insert the key and test for proper operation.

Note: The plug follower is not required while reassembling.

Rekeying Levers

Step-by-step instructions for:

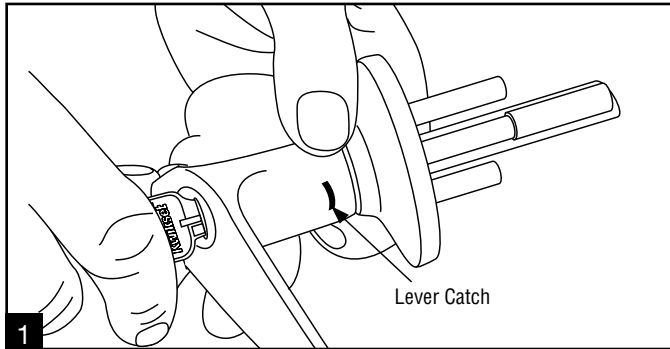
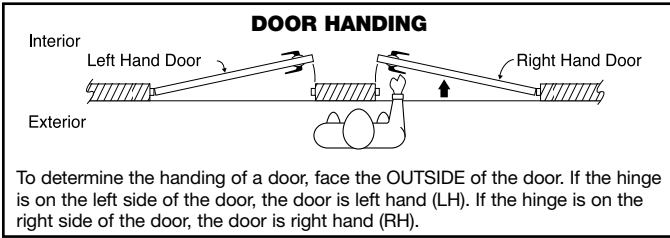
Insert the key and unlock the leverset. The lever cannot be removed if the leverset is in the locked position. Remove the key.

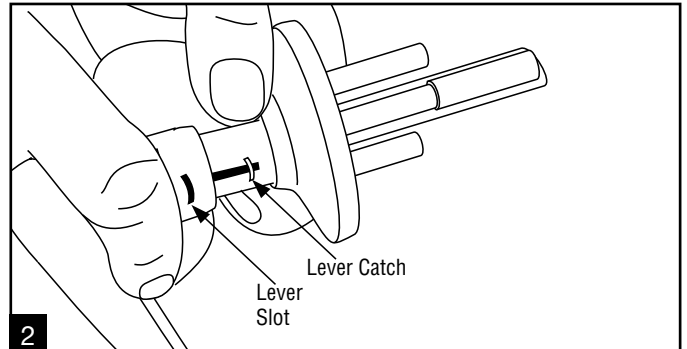

Using a small screwdriver, press in the lever catch and remove the lever from the assembly (wiggling the lever a little will aid with its removal). The cylinder assembly will be in the sleeve or the removed lever. Remove it.

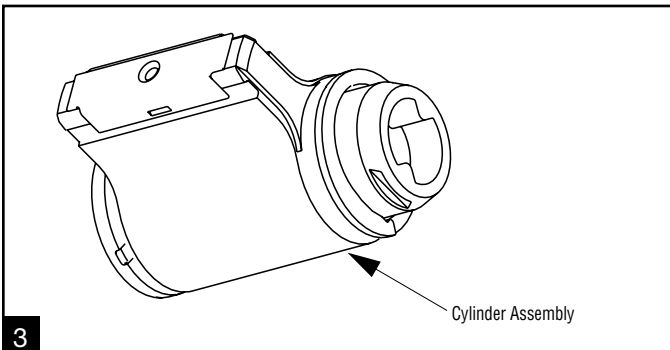

The cylinder assembly is now ready to be rekeyed. Rekeying this cylinder is the same as steps 7 - 11 on page 17.

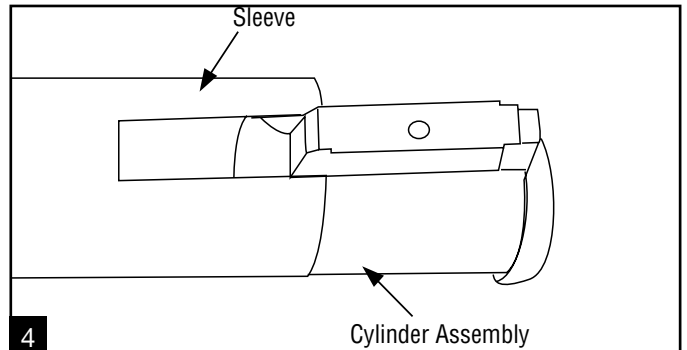

After rekeying the cylinder assembly insert the cylinder into the outside sleeve as shown. Some wiggling may be required for the cylinder assembly to seat fully in the sleeve.

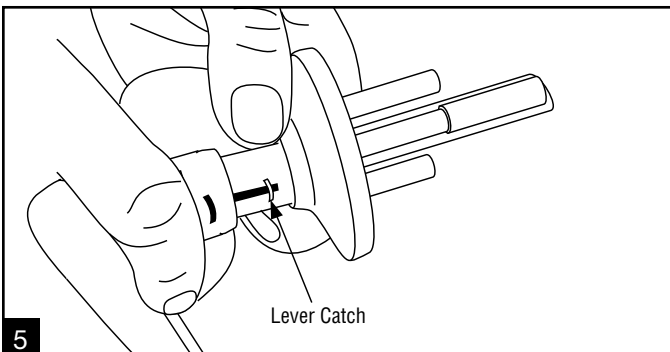

Slide the lever over the sleeve and cylinder assembly.

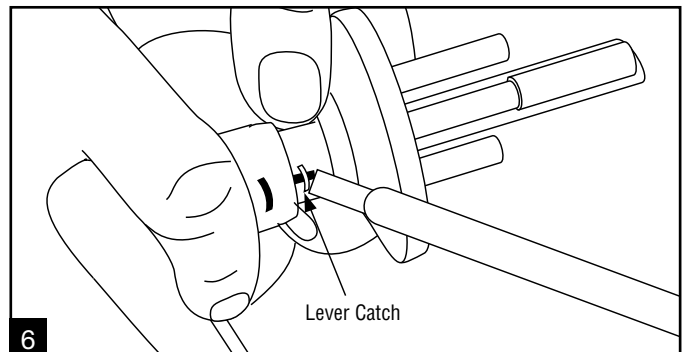

With a small screwdriver, depress the lever catch and continue pushing and slightly rotating the lever onto the sleeve until the catch locks the lever in place. The leverset is now rekeyed.

Step-by-step instructions for:

Kwikset
UltraMax
SECURITY

Rekeying UltraMax Levers For Commercial Series Levers

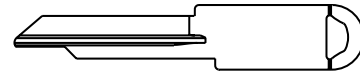

Control key for UltraMax Commercial #81804
(when cutting the above control key, do not remove control key tip)

For when a control key is not available, but the homeowners key is.

If you can cut a control key to match the existing key, continue with steps 5–13 in UltraMax Knobs on page 14.

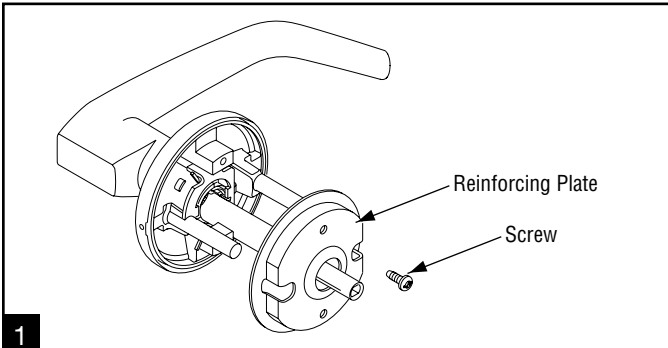

1

Unscrew and remove the reinforcing plate (1 screw).

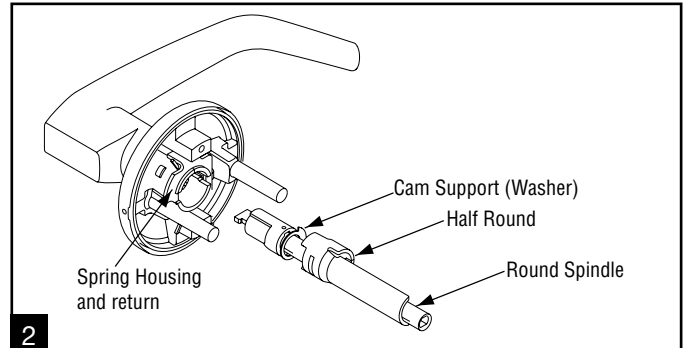

2

Remove round spindle assembly (round spindle, half-round, and washer). Keep assembly together.

CAUTION: Do not disturb spring housing and return.

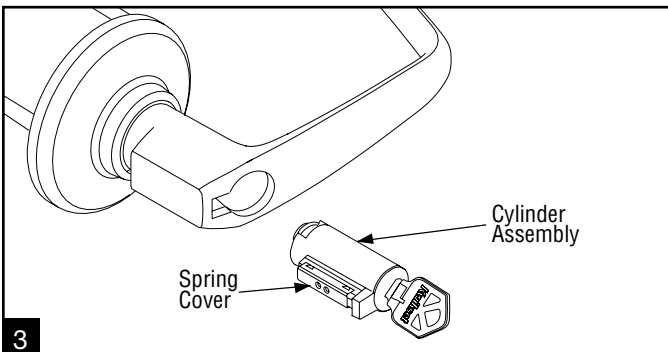

3

Insert key and turn 180° to the position shown. Pull out the cylinder assembly (if homeowners key is not available, cylinder must be picked). Continue with steps 5–13 in “UltraMax Knobs on page 14 - 15.

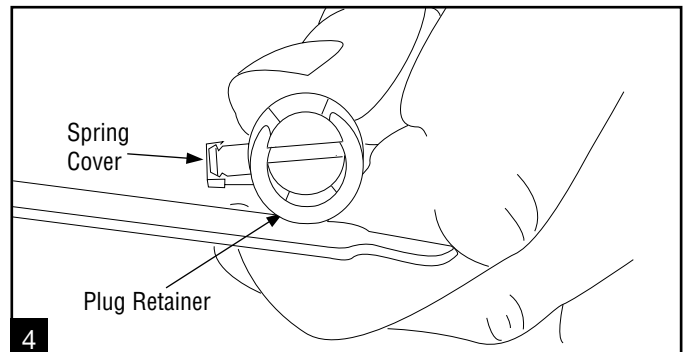

4

Looking at the rear of the plug with the spring cover to your left, use the cylinder removing tool to re-seat the plug retainer from the bottom as shown. Insert key, and turn 180° and replace cylinder assembly into the lever, turn key 180° and remove. Spring return and housing must be seated properly for the cylinder to lock in place.

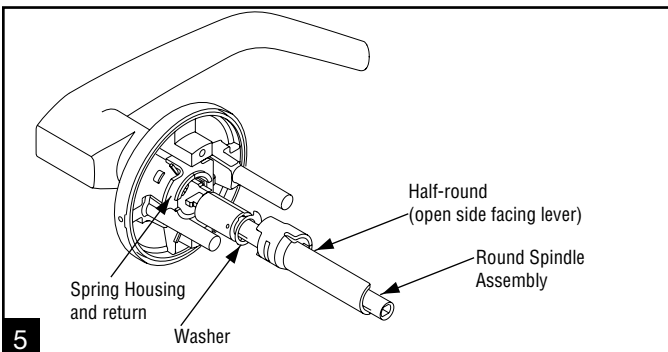

5

Insert round spindle assembly (spindle, half-round and washer), in opening by aligning the paddle, at the end of the spindle assembly, to the matching slot in cylinder. Once assembled, half-round opening faces lever.

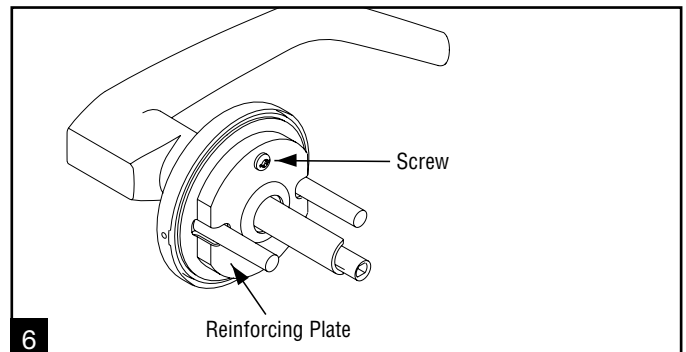

6

Replace reinforcing plate and screw down. If the plate is not flush, the spindle assembly is not in proper position.

Rekeying Handlesets

For Sonoma Handleset, see instructions for 780/970 Deadbolt

Step-by-step instructions for:



The principle is identical, but a some of the parts are different, requiring a few different steps in taking apart the lock and putting it back together. On Kwikset's current keyed handleset, the Gibson, the cylinder is removed from the back (the shell is part of the handle rose).

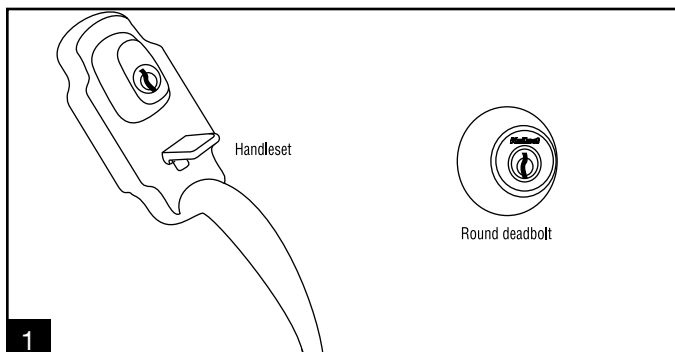

On the Gibson handleset, the handle rose and cylinder's protective housing are all one piece. The cylinder is removed from the rear.
Note: If you have the round or matching deadbolt, see the section on rekeying Kwikset deadbolts.

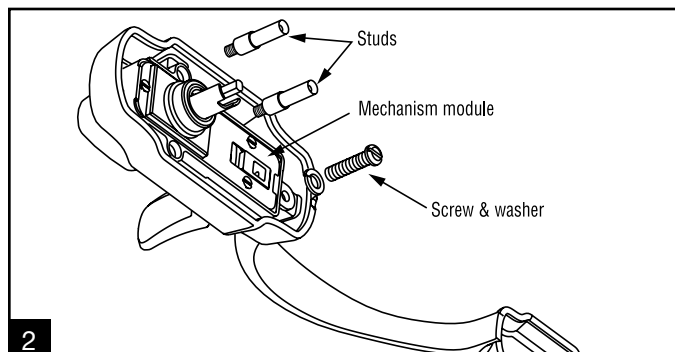

Remove the two studs from the mechanism module sides and the screw and washer at the bottom and set these parts aside. The handle is now detached.

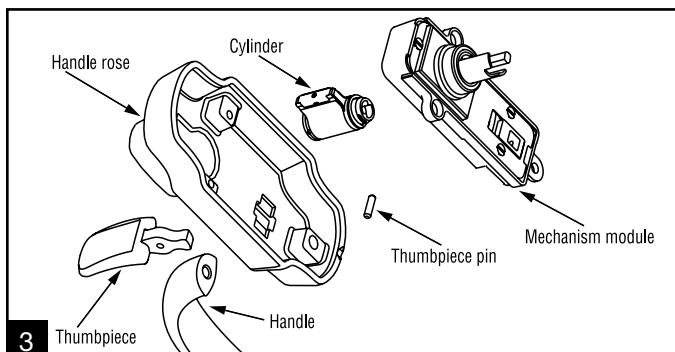

Remove the mechanism module, thumbpiece pin and thumbpiece and set these parts aside. The cylinder is now free.

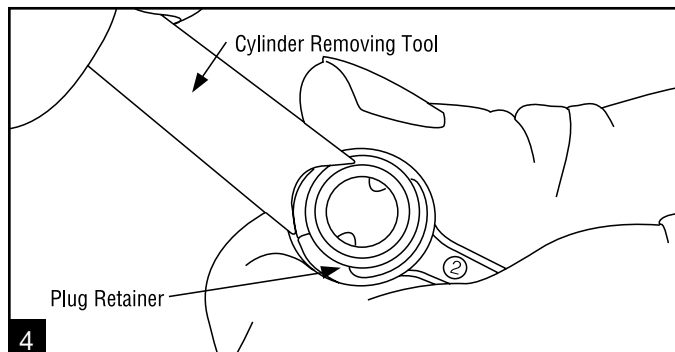

From here on, the steps are identical to rekeying a lockset. Start by removing the plug retainer.

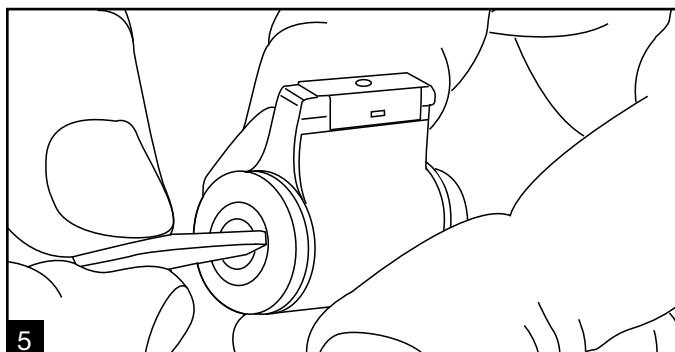

Insert the existing key for the lock and turn it 45° to the right or left. Keep key at this angle for next step.

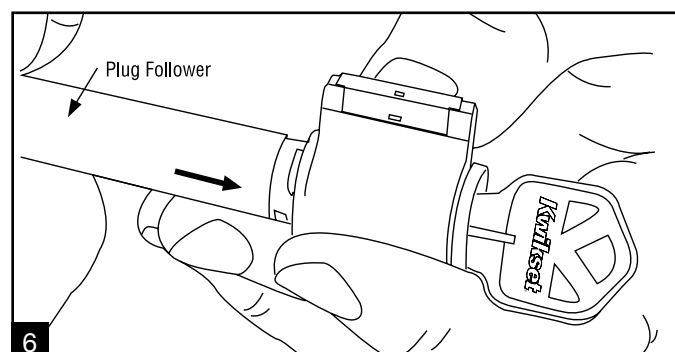

Place the flat end of the plug follower at the back of the plug and push smoothly through the cylinder until the follower is out at least an inch.

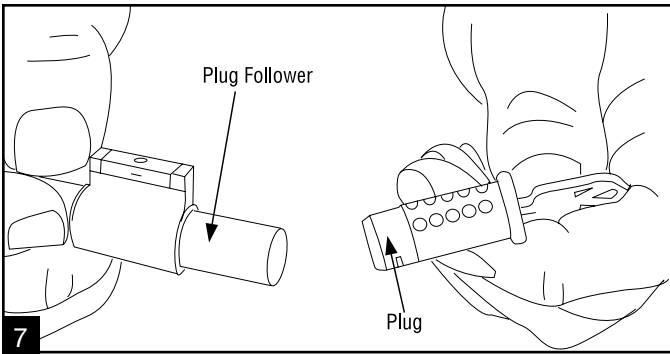

7 Insert the new key. Dump and discard the old pins (If you didn't gauge the key before starting, do it now and lay out the pins in order — from the bow to tip). Leave new key in place.

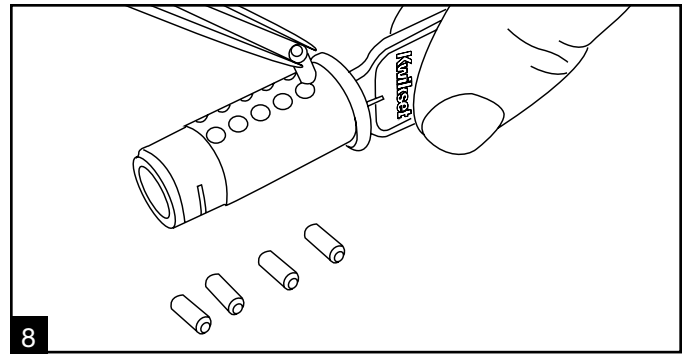

8 Begin dropping in the appropriate pins (this is a 6-5-4-4-5). If all the bottom pins are the proper size for the key, they will be at the shear line - even with the surface of the plug. **Check this carefully.** A pin which is too long will prevent insertion of the plug while the key is inserted. A pin which is too short will allow the cylinder to lock up with no key operation!

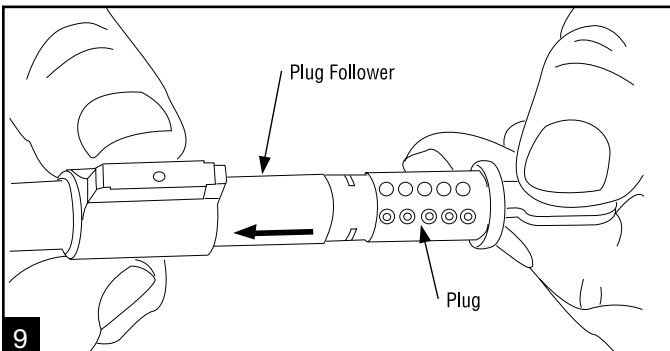

9 Holding the key 45° right or left of vertical, use the plug to push the follower back through the cylinder.

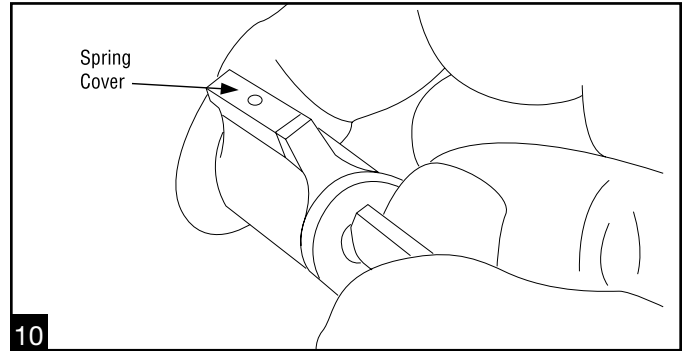

10 Turn the key so it's in line with the spring cover on top of the cylinder. Hold your thumb against the plug face and pull the key out carefully. Do not allow the plug to slide out.

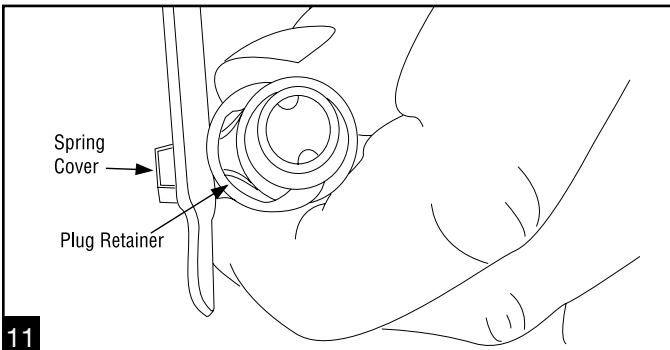

11 Replace the plug retainer from the direction of the pin cover. Remember to align the open end with the groove in the plug. **CHECK CAREFULLY-If plug retainer is replaced incorrectly, the lever may not lock onto sleeve.**

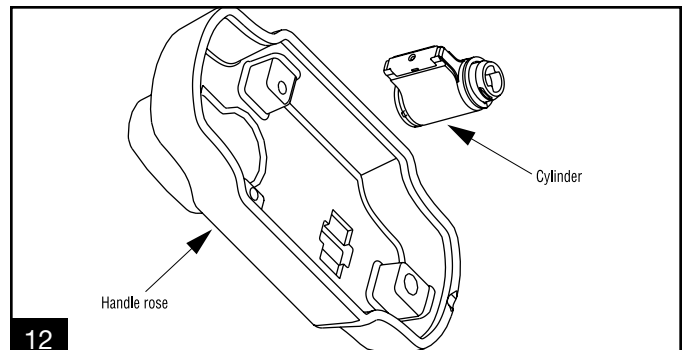

12 Insert the newly pinned cylinder back into the handle rose.

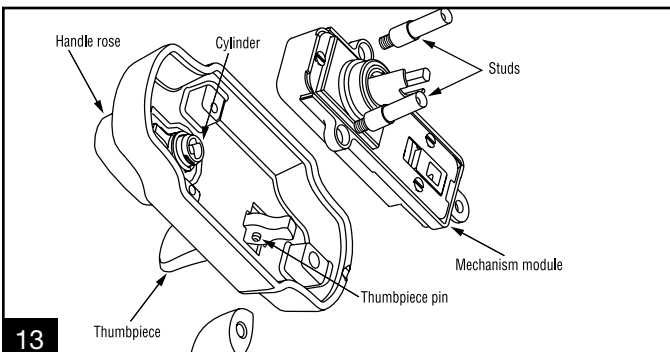

13 Place the thumbpiece into the handle rose slot as shown and slide the thumbpiece pin through the hole in the back of the thumbpiece. The mechanism module keeps the pin in place. Attach the mechanism module with the 2 stud screws.

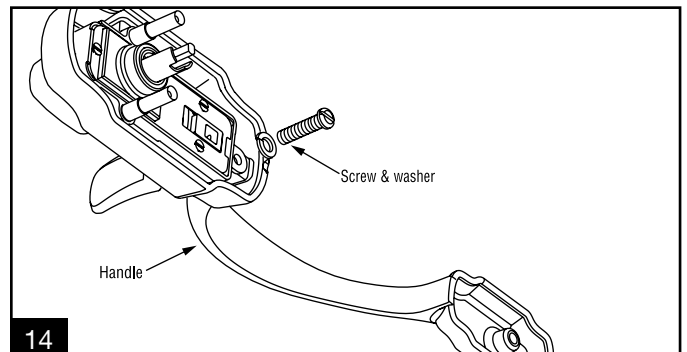

14 The remaining screw and washer assembles the bottom hole in the mechanism module with the handle.

Rekeying Deadbolts

Step-by-step instructions for:

Kwikset
Security

Kwikset
Maximum
SECURITY

A lot of people are buying Kwikset deadbolts in these security-conscious days. And when they do, you're the one to suggest keying them alike with their entry locksets. In rekeying a deadbolt, the principle is exactly the same as the rekeying of an entry lock, but a few of the parts are different.

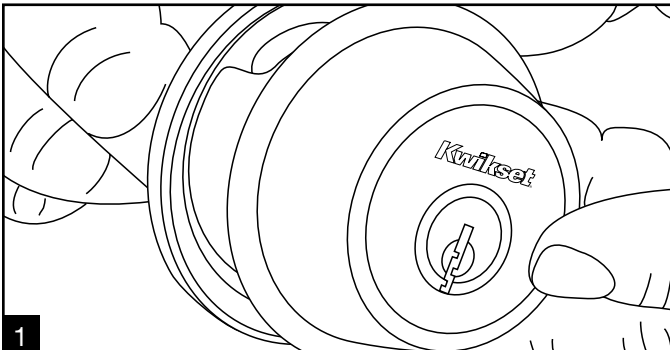

1 With single cylinder deadbolts, you'll only be dealing with the exterior side of the lock. With double cylinder locks, both sides must be rekeyed.

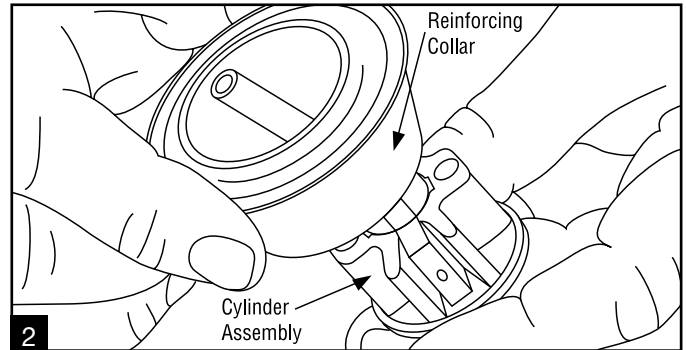

2 Turn the cylinder face down and remove the reinforcing collars.

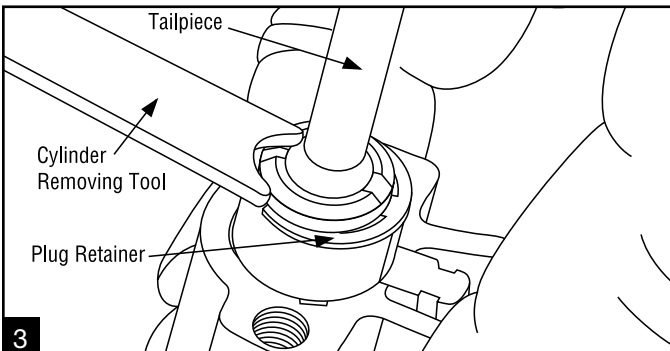

3 To remove the tailpiece, fit the forked end of the Cylinder Removing Tool into the open end of the plug retainer and push it out.

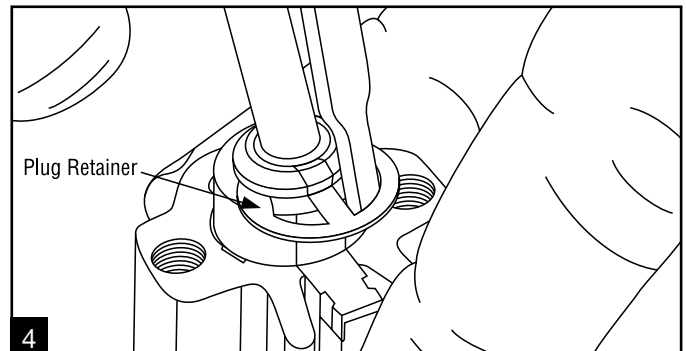

4 Move the plug retainer out the rest of the way with the other end. **Use care not to deform retainer.**

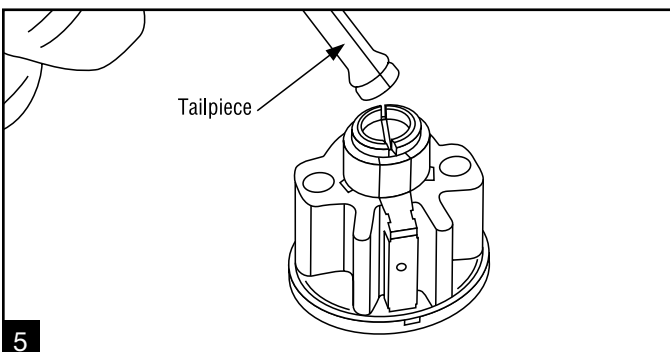

5 Remove the tailpiece and proceed the same as you did with the knob lock.

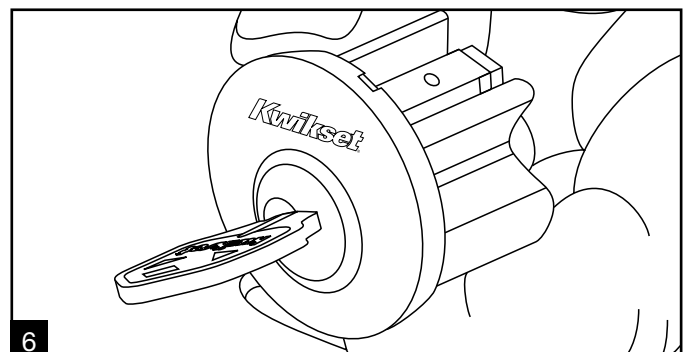

6 Insert the old key, turn it 45° to the right or left. Keep key at this angle for next step.

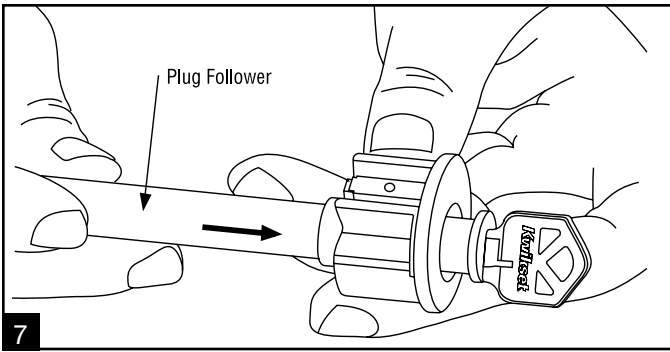

Use the flat end of the plug follower to push the plug slowly and evenly out from the back. Make sure the follower sticks out at least an inch. **Leave it in place until you reassemble.**

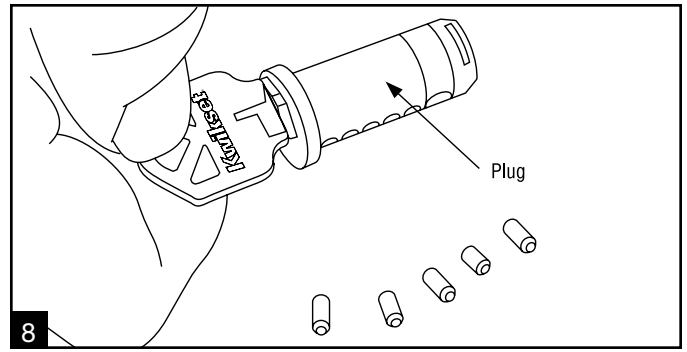

Dump and discard the old pins. Remove old key and insert new key. (We assume you have already gauged the new key.)

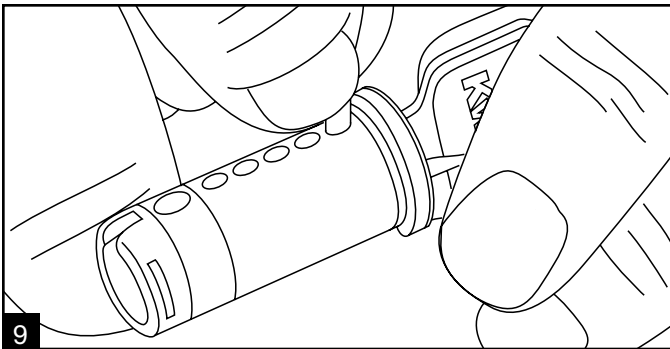

Install the new pins according to the bitting (combination) of the new key. As mentioned earlier, whether you handle the pins with tweezers or your fingertips is your choice.

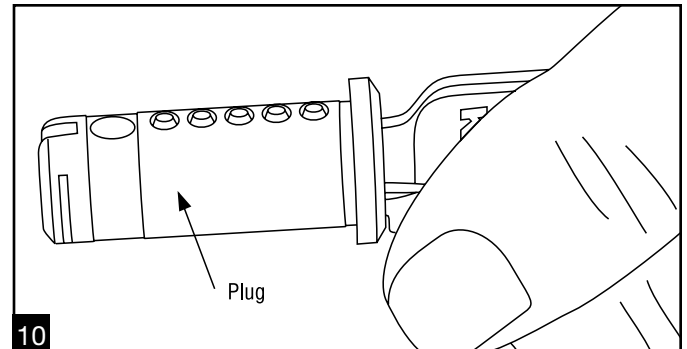

If all the bottom pins are the proper size for the key, they will be at the shear line -- even with the top surface of the plug. **Check this carefully.** A pin which is too long will prevent insertion of the plug while the key is inserted. A pin which is too short will allow the cylinder to lock up with no key operation!

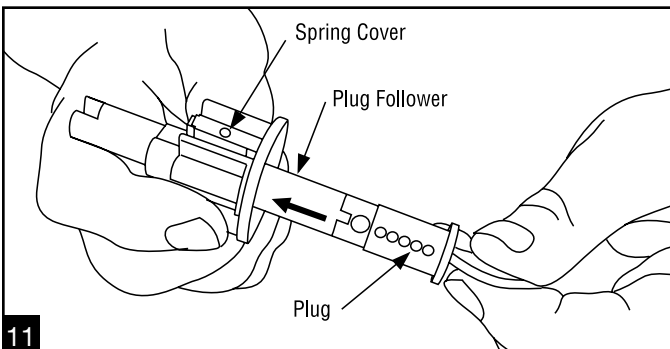

Reassemble the same way. Turn the key 45° to the right or left of the spring cover. Use the plug to push the follower back through the cylinder gently and evenly.

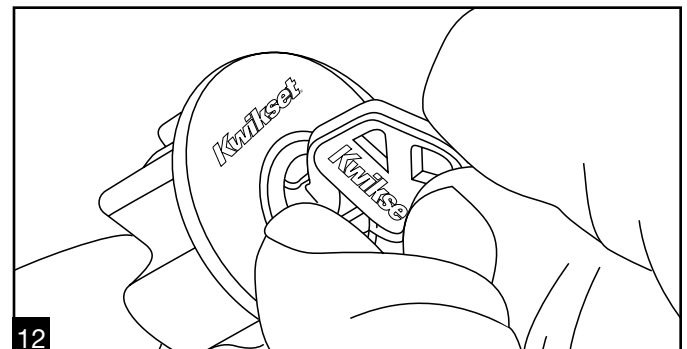

Holding the plug firmly in the cylinder with your thumb, turn the key straight up and remove it carefully.

CAUTION: Do not allow plug to come out as you remove the key!

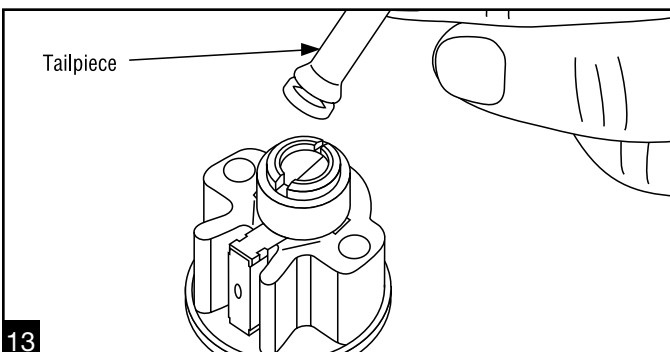

Install the tailpiece. If servicing a double cylinder model, be sure each cylinder has the right tailpiece. Align the notches in both the plug and tailpiece.

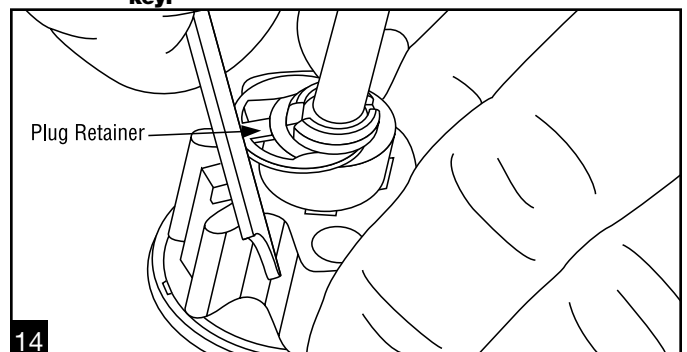

Use the Cylinder Removing Tool to reset the retainer. Insert the key and test for proper operation.

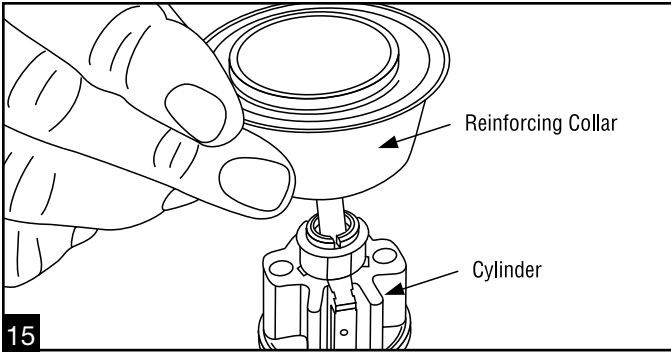

15 Put the reinforcing collar and cover back on.

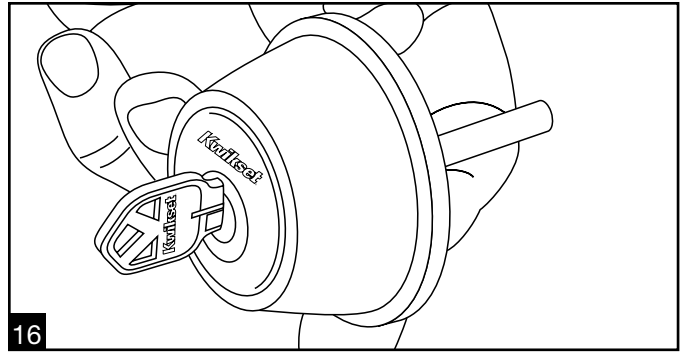

16 Your deadbolt rekeying is complete. If your customer has purchased a Kwikset double cylinder model, simply rekey the other cylinder in exactly the same manner, and to the same combination.

Step-by-step instructions for:



Rekeying 780 Deadbolt with a control key

When making a new key, also make a new control key with the same bitting (combination) as the new key.

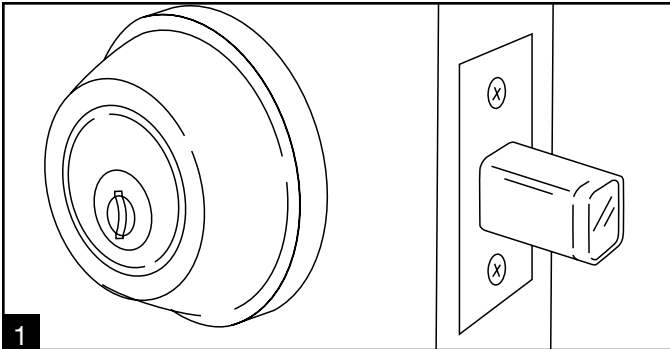

1
Deadbolt on door.

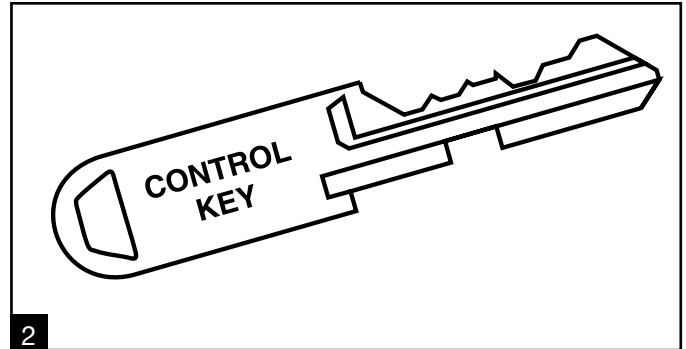

2
Locate the special "control key" which is cut specifically for the combination of your lock, but with a notch on the bottom of the key blade.

NOTE: If not available, cut a blank "control key" to match existing key.

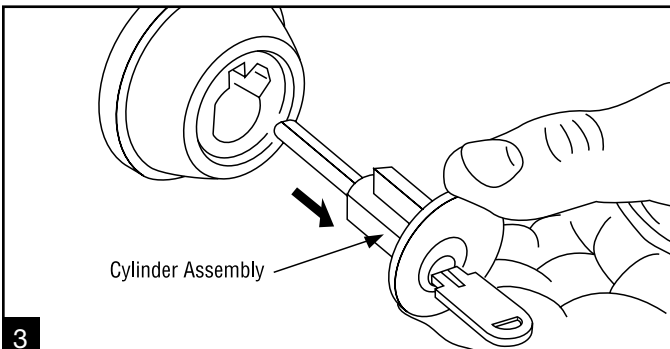

3
Insert this control key fully and turn it 120° (slightly more than 1/4 turn) counterclockwise. Pull the cylinder assembly straight out. Turn the key back to the vertical position and remove it.

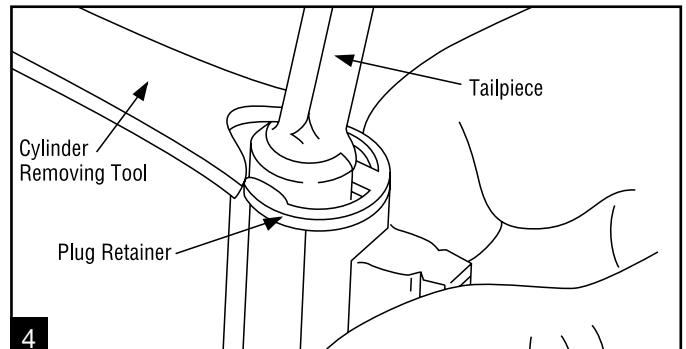

4
Lay the cylinder assembly face down on a flat surface. The tailpiece must be removed. To do this, fit the forked end of the Cylinder Removing Tool into the open end of the plug retainer and push it out. If the cylinder has a sleeve on the tailpiece, remove first and set aside.

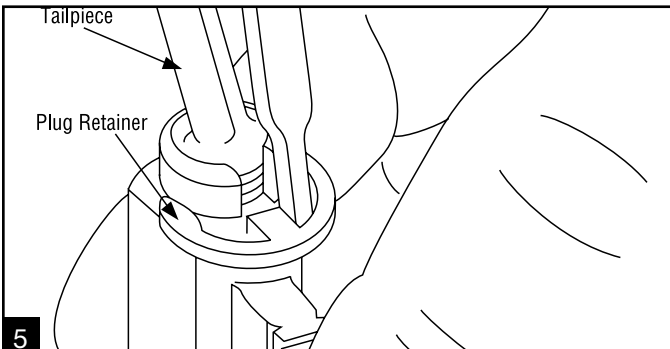

5
Remove the retainer completely using the other end of the tool. **Use care not to deform retainer.**

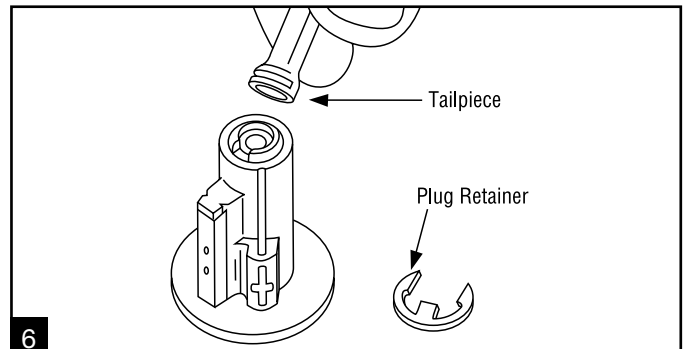

6
Lift out the tailpiece.

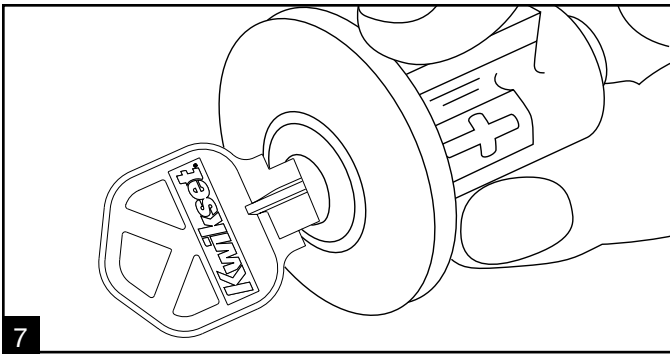

7
Insert old key or Control Key, turn 45° to the right or left. Keep key at this angle for next step.

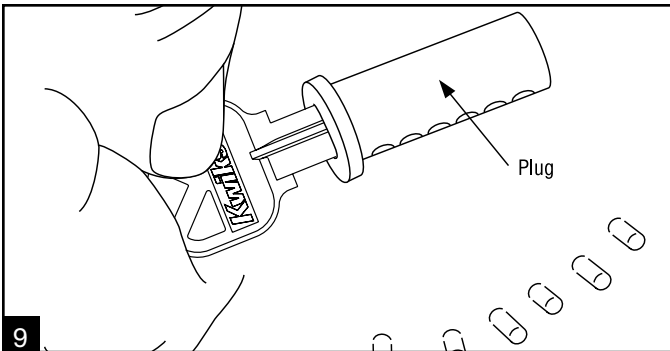

9
Drop out the old pins, remove the old key and insert the new key. (We will assume you have already gauged the new key.)

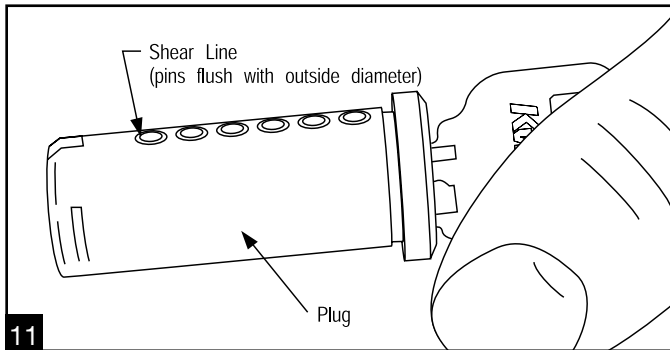

11
If all the bottom pins are the proper size for the key, they will create the shear line. **Check this carefully.** A pin too long will prevent insertion of the plug while the key is inserted. A pin too short will allow the cylinder to lock up with no key operation, which will require complete disassembly.

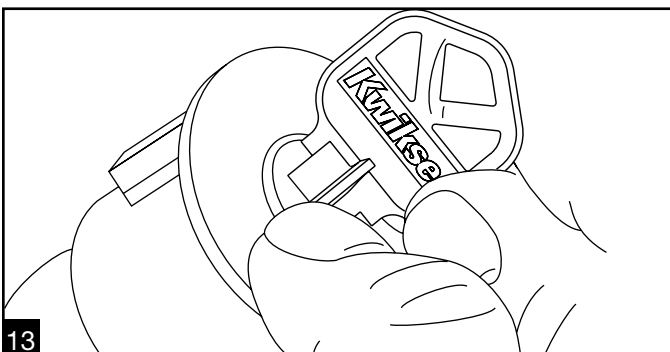

13
Holding the plug firmly in the cylinder with your thumb, turn the key straight up and remove it.

CAUTION: Do not allow the plug to come out as you remove the key.

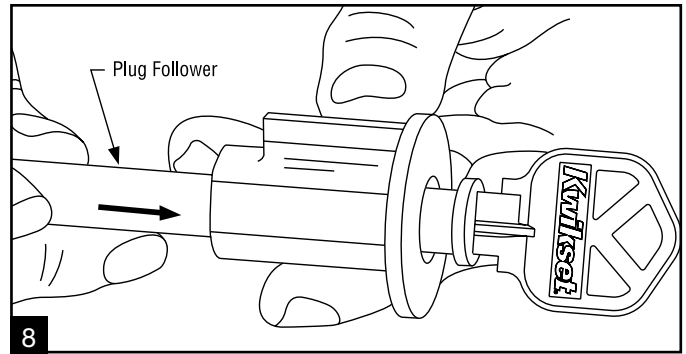

8
Using the follower, push the plug out from the back. Make sure it stays tight against the plug or the top pins and springs will fall out (see page 19 if top pins and springs fall out). Also, make sure the follower sticks out at least one inch. **Leave it in place until you reassemble.**

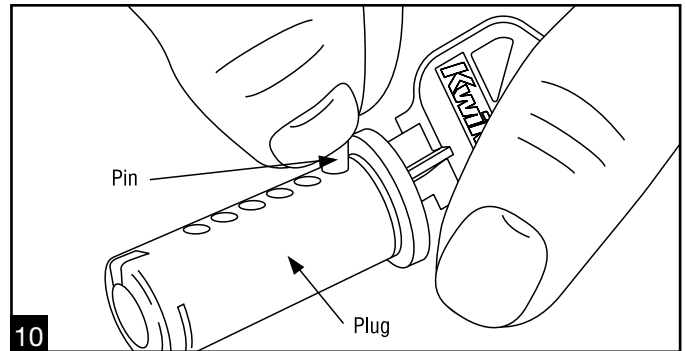

10
Begin inserting the new bottom pins from the rekeying kit according to the cut combination of the new key. You may handle the bottom pins with tweezers or your fingertips. As in our example (324625), use a #3 bottom pin for position one (which is a "3" depth on the key). A #2 bottom pin for position two, #4 pin for position 3, etc. Pins actually used will correspond with the key available.

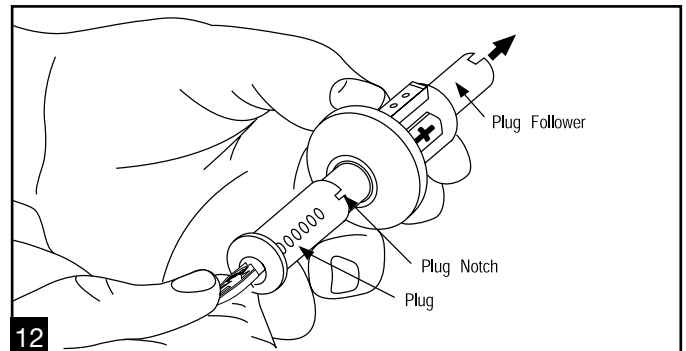

12
Begin reassembly in the same manner you started; position the key 45° to the right or left so that the top pins will not fall into the cylinder. Then use the plug to push the follower back through the cylinder.

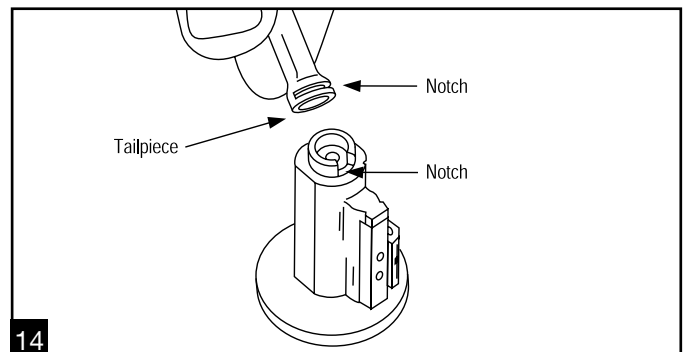

14
Install the tailpiece with the notches in the plug and tailpiece aligned.

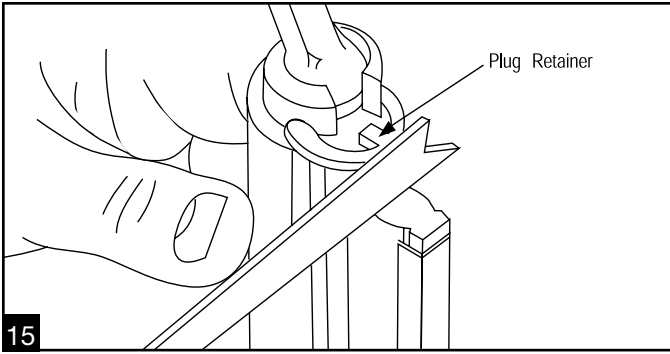

Use the cylinder removing tool to reseat the plug retainer. Then insert the key and test to make sure everything turns and operates properly. **If a tailpiece sleeve was used with your particular model and removed for rekeying, replace it now.**

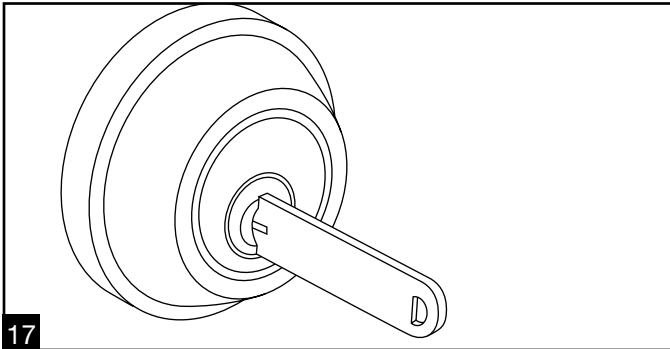

Insert cylinder assembly into deadbolt.

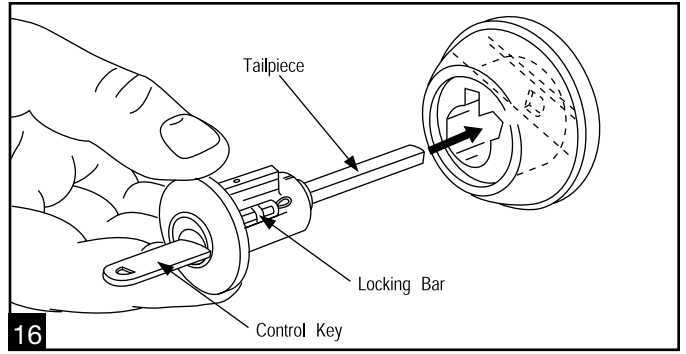

Turn the new control key (cut to match new deadbolt key) about 120° counterclockwise until locking bar is flush with the cylinder body. Look into the cylinder hole to observe the orientation required for the tailpiece. Rotate the tailpiece accordingly.

Model 780 (single cylinder) — Make sure the tailpiece aligns properly with latch hole and thumbturn hole.

Model 785 (double cylinder) — When inserting outside cylinder, turn control key to vertical position with cuts of key up. This will turn the solid tailpiece so it will not droop down. Insert cylinder assembly into lockset until it stops. Rotate the control key clockwise until locking bar is flush with cylinder. Then push cylinder in fully. Rotate tool clockwise to vertical position and withdraw. Check with new deadbolt key for proper function.

Rekeying 780 & 980 Deadbolt without a control key

(If no control key exists, use the customer's existing key to cut one. When making the new key, also make a new control key with the same bitting (combination) as the new key.)

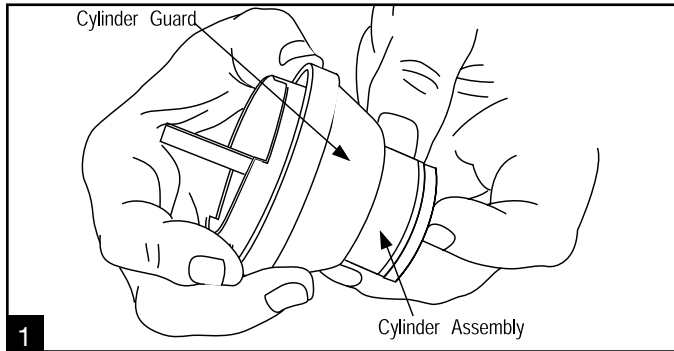

1 Remove cylinder assembly from cylinder guard.

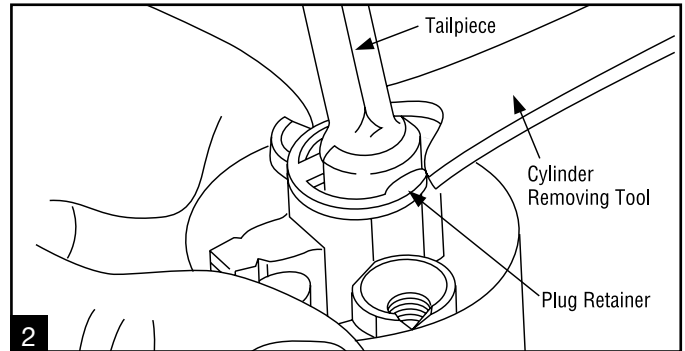

2 Disengage the plug retainer by pushing the forked end of the cylinder removal tool into the open end of the retainer and pushing it out. If the cylinder has a sleeve on the tailpiece, remove first and set aside.

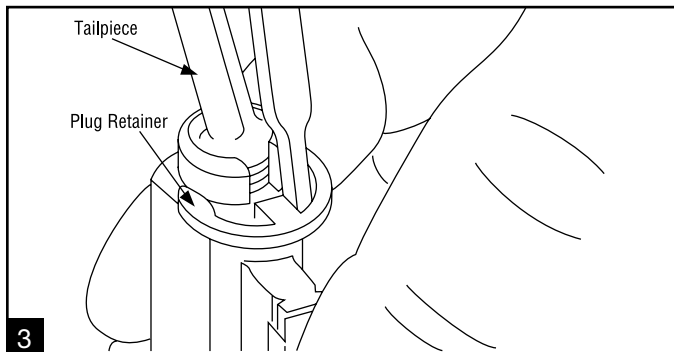

3 Remove the retainer completely using the other end of the Cylinder Removing Tool. **Use care not to deform retainer.**

Lift out the tailpiece.

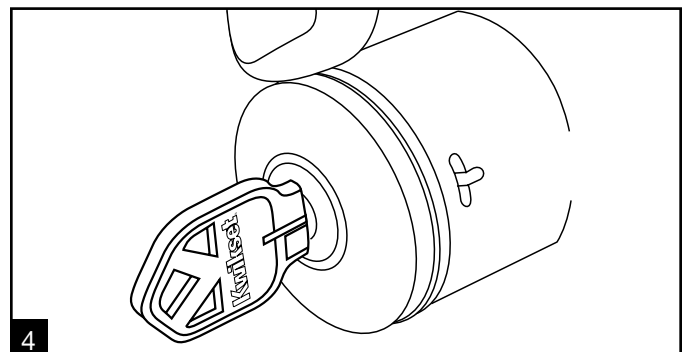

4 Insert old operating key and turn 45° to the right or left. Keep key at this angle for next step.

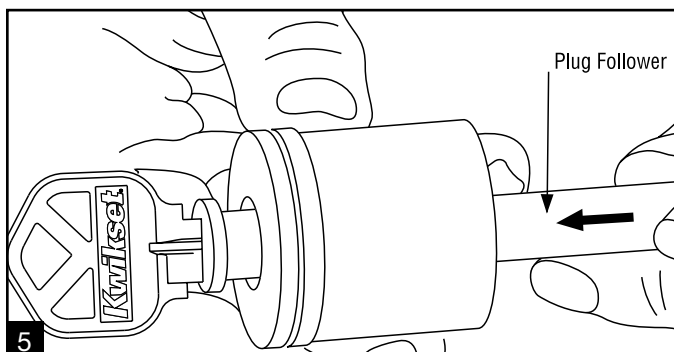

5 Using the plug follower, push the plug out from the back. Make sure the Plug Following Tool stays tight against the plug or the top pins and springs will fall out (see page 00 if this happens). Make sure the follower sticks out at least one inch. **Leave it in place until you reassemble.**

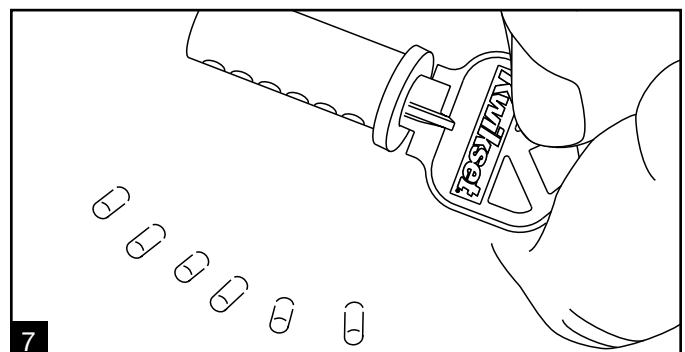

7 Drop out the old pins, remove the old key and insert the new key. (We will assume you have already gauged the new key.)

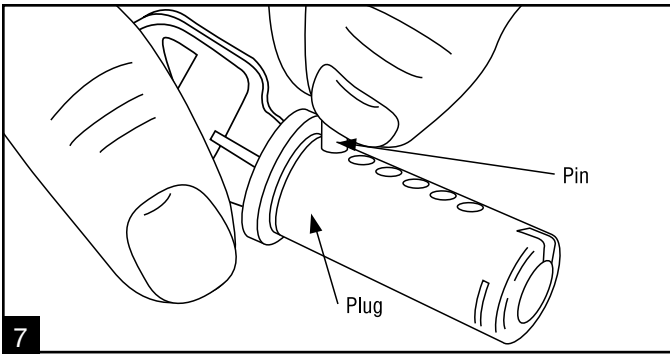

Begin inserting the new bottom pins from the rekeying kit according to the cut combination of the new key. You may handle the bottom pins with tweezers or your fingertips. As in our example (324625), use a #3 bottom pin for position one (a 3 depth on the key). A #2 bottom pin for position two, #4 pin for position three, etc. Pins actually used will correspond with the key available.

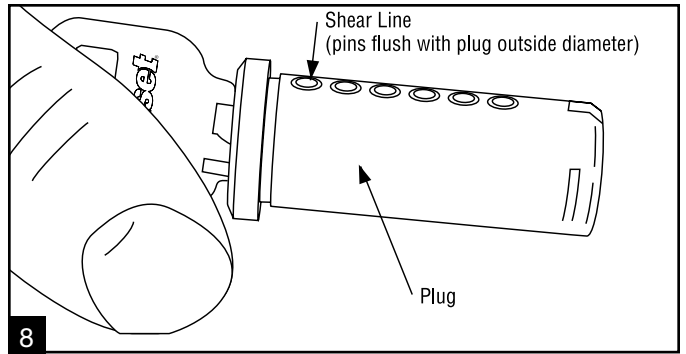

If all the bottom pins are the proper size for the key, they will create the shear line. **Check this carefully.** A pin too long will prevent insertion of the plug while the key is inserted. A pin too short will allow the cylinder to lock up with no key operation, which will require complete disassembly.

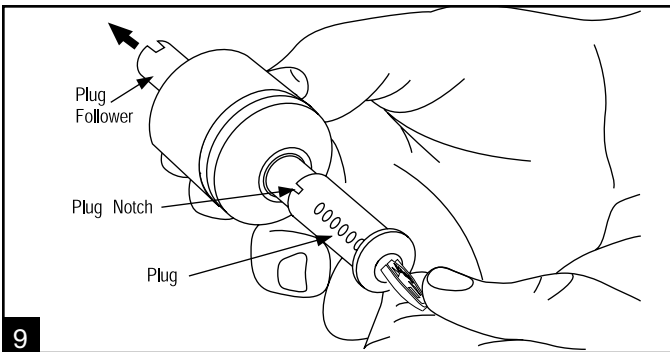

Begin reassembly in the same manner you started; position the key 45° to the right or left so that top pins will not fall into the plug notch, then use the plug to push the follower back through the cylinder.

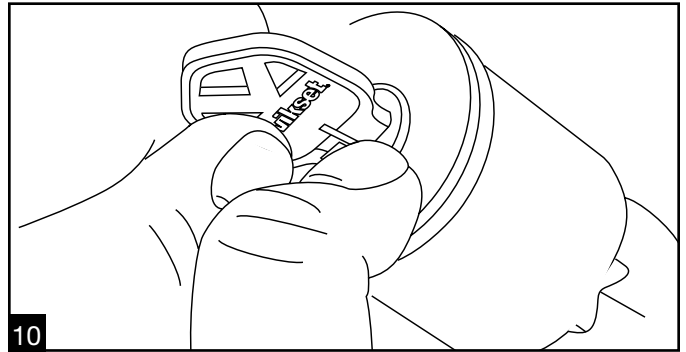

Holding the plug firmly in the cylinder with your thumb, turn the key straight up and remove it.

CAUTION: Do not allow the plug to come out as you remove the key!

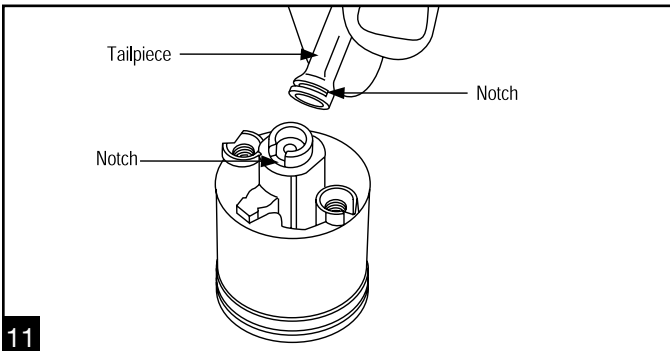

Install the tailpiece with the notches in the plug and the tailpiece aligned.

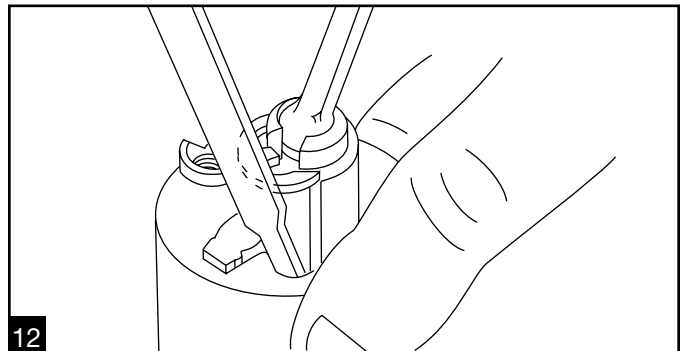

Use the cylinder removing tool to reseat the plug retainer. Then insert the key and test to make sure everything turns and operates properly. If a tailpiece sleeve was used with your particular model and removed for rekeying, replace it now.

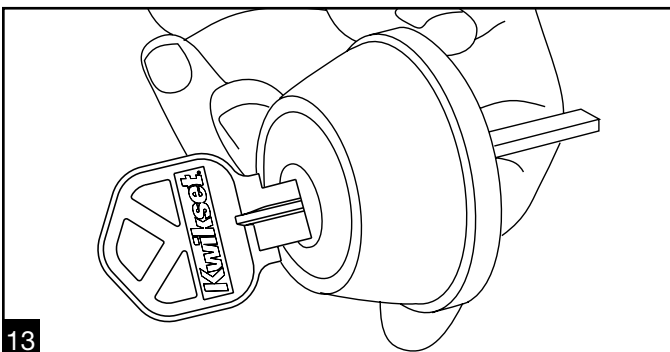

Insert the rekeyed cylinder back into the collar assembly. Rekeying is complete. If your customer has purchased a double cylinder model, simply rekey the other cylinder in exactly the same manner, and the same combination. Check for proper operation.

Rekeying 780 & 980 Deadbolt without a key or control key



Procedure to remove cylinder assembly from housing. This also applies to TITAN NightSight products.

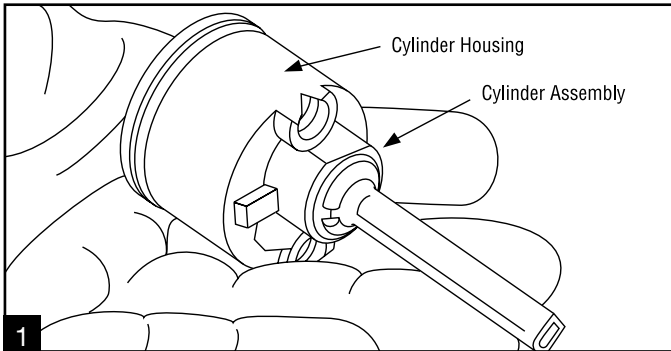

1 Complete cylinder assembly.

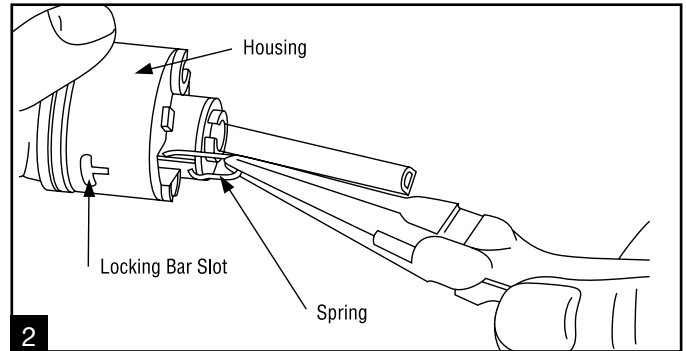

2 Remove spring with long nose pliers. Pull straight back, using care not to deform spring. Use the U-shaped spring you just pulled out to pick out the locking bar from the slot in the housing.

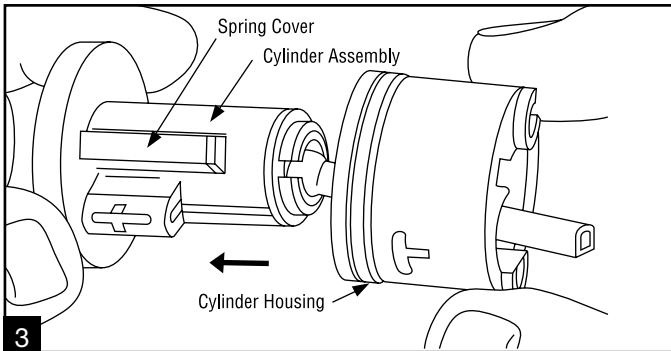

3 Remove cylinder assembly from housing. Then disassemble by removing spring cover and dropping out all pins and springs. Remove plug retainer and plug. Begin rekeying with new keys and reassemble locking bar and spring with housing, while using methods described in Section III step 12.

Notes: If a control key is made, the cylinder assembly can be installed into the housing easily. Follow instructions on rekeying with a control key.

However, if only a standard operating key is used, follow Section III instructions (rekeying if top pins and springs accidentally drop out.)

Step-by-step instructions for:

Kwikset
UltraMax
SECURITY

Rekeying 980 Deadbolts

What to do if the top pins and springs drop out during rekeying

This section deals with the situation when an accident occurs using a follower and one or more top pins and springs come out of the cylinder shell. Now, all the top pins, springs and spring cover must be removed.

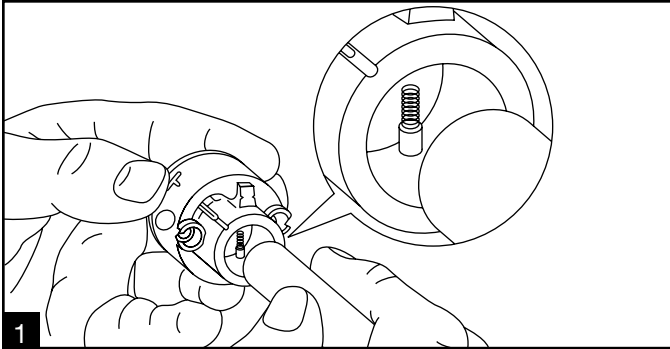

1 Pins and springs accidentally drop.

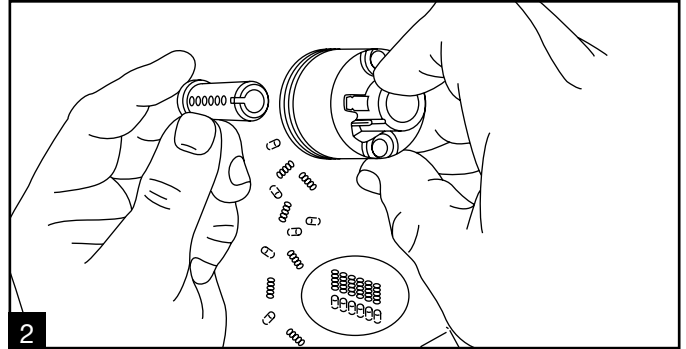

2 Pull plug completely out of cylinder shell allowing all top pins and springs to fall out. Carefully remove the spring cover. Do not deform it during removal or you will have to replace it with a new one.

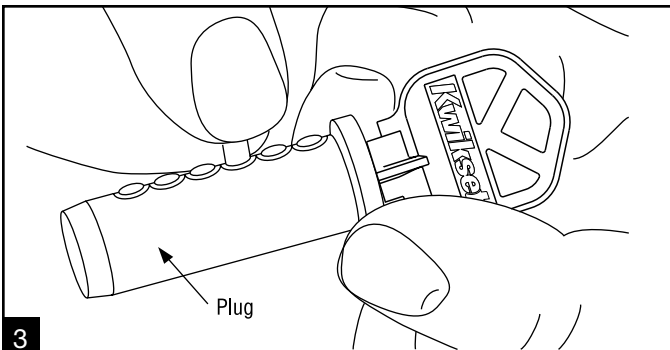

3 Insert the new key into the plug and add correct bottom pins to be flush with the shear line. (Outside surface of plug.)

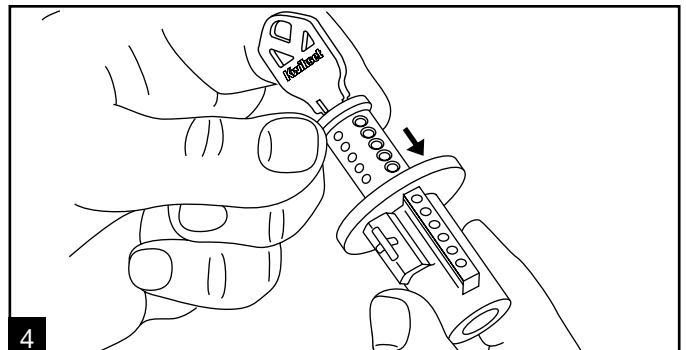

4 Insert the loaded plug (with key still inserted) into cylinder shell.

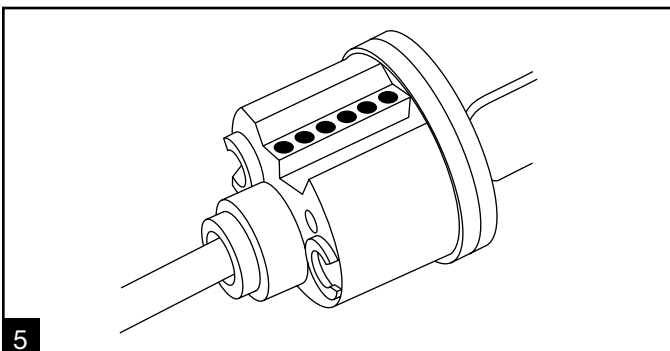

5 Insert/install the tailpiece and plug retainer.

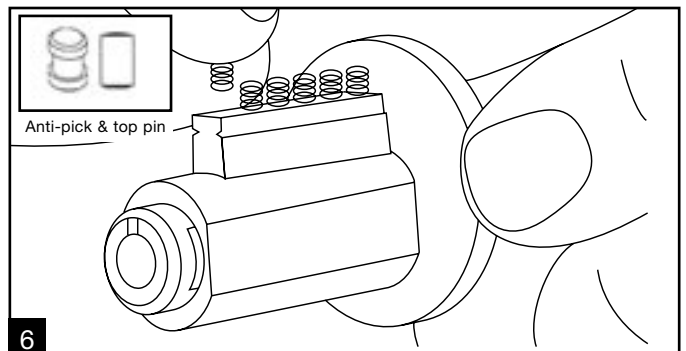

6 Add one top pin then one spring to each pin chamber. The anti-pick top pins should be placed in the first three pin chambers (1,2,3). By placing the conventional top pins (with full diameter) in the last chambers (4, 5, 6), this will provide smoother operation during the key insertion process. Conventional top pins will reduce plug rotation and maintain better chamber hole alignment between plug and cylinder body. Because tumblers 4, 5, and 6 are the last to be raised during key insertion, they will hold the plug during this process.

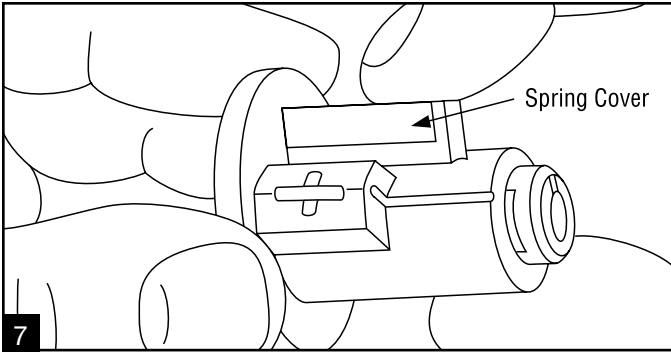

Install the spring cover by applying even pressure over springs until all four detent clamps are engaged.

Step-by-step instructions for:

SOCIETY BRASS
COLLECTION

Rekeying Knobs & Levers

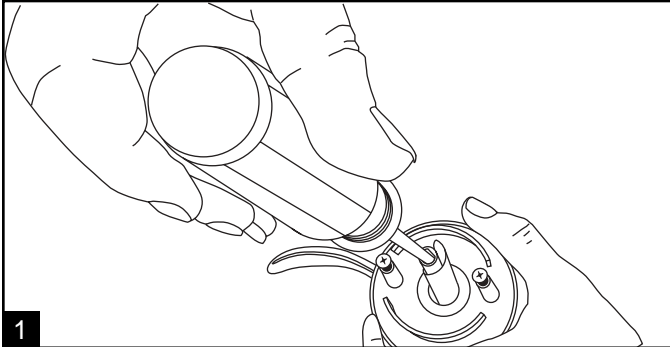

1

Remove product from box, look into end of spindle.

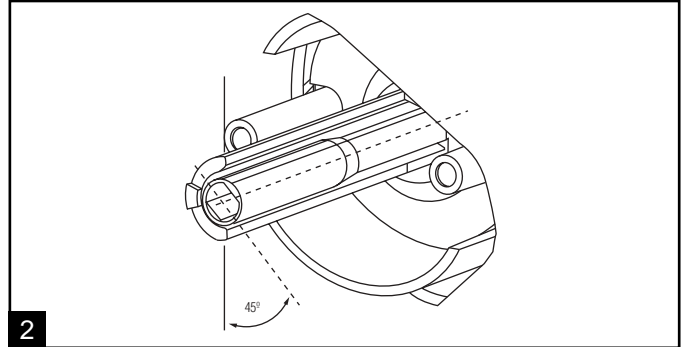

2

With a slotted screwdriver, turn spindle so that it is 45° to the half-round. Or . . .

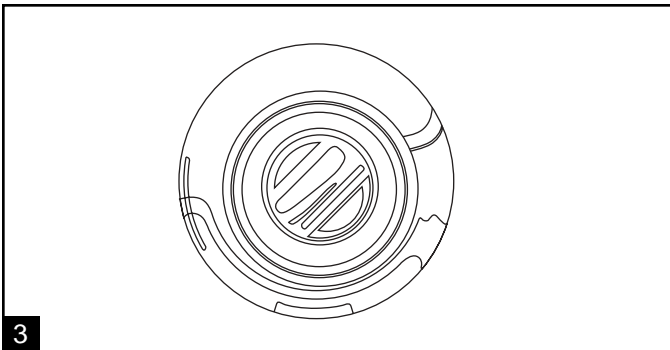

3

. . . if product is installed, turn button to 45°.

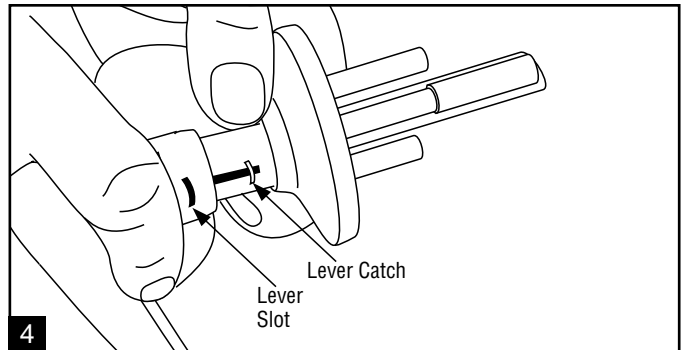

4

Depress lever catch (with a slotted screwdriver) to remove from chassis, if the lever catch does not depress easily, check your 45° angle.

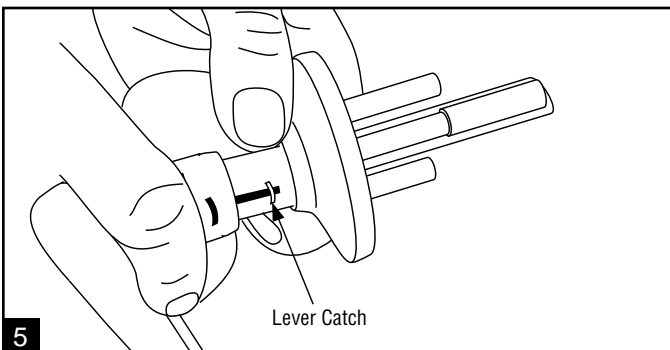

5

Slide knob or lever off the chassis. There are no screws to remove on the lever so just slide off interior shield and the cylinder will then come out.

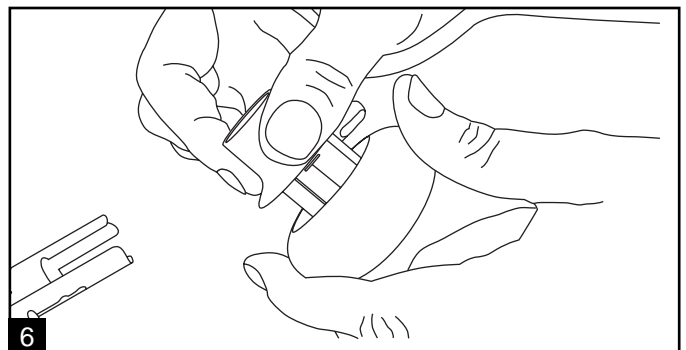

6

For Windham and Bedford knobs, slide the exterior sleeve off.

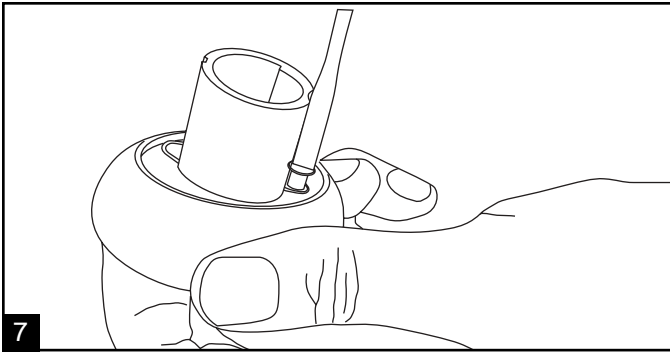

7 Using a slotted or torque screwdriver, remove both screws from the knob.

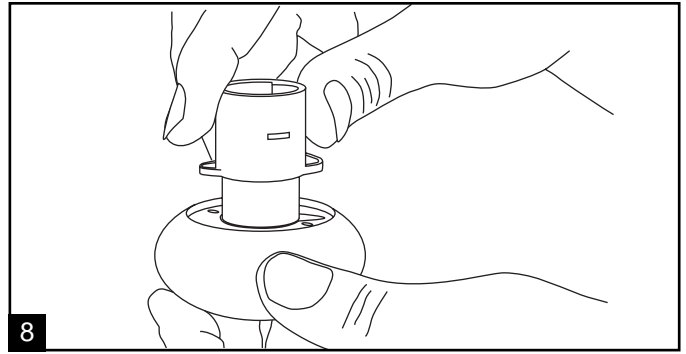

8 At this point, remove the interior sleeve.

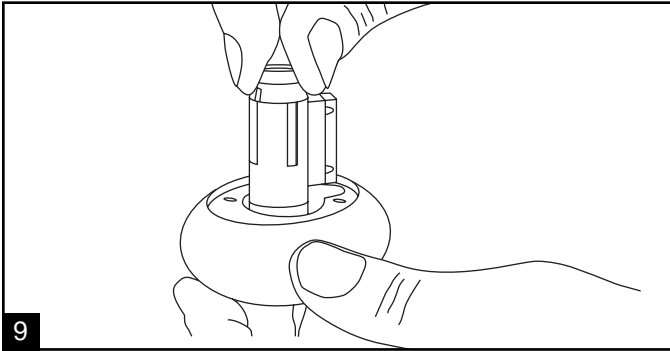

9 Remove the cylinder from the knob. You can now re-key the lock.

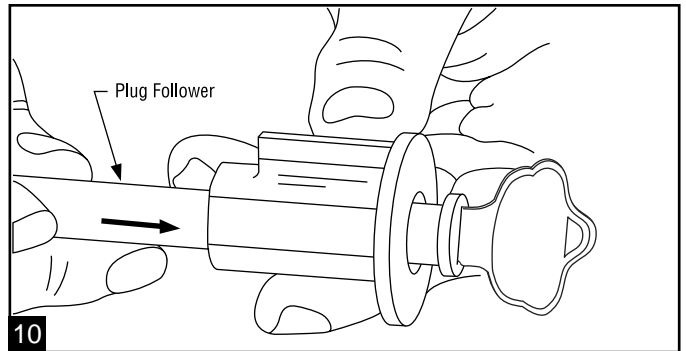

10 Remove C-clip and turn key off center. Using the follower, push the plug out from the back. Make sure it stays tight against the plug or the top pins and springs will fall out (see page 23 if top pins and springs fall out). Also, make sure the follower sticks out at least one inch. **Leave it in place until you reassemble.**

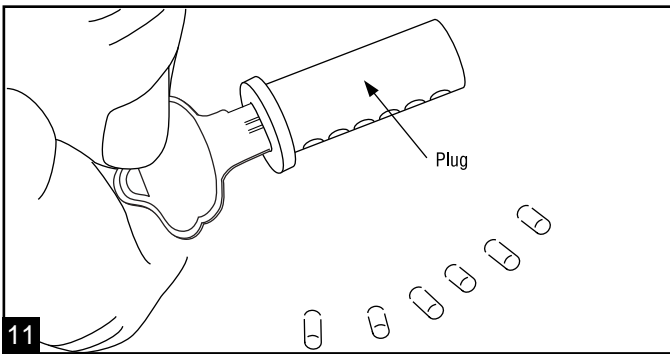

11 Drop out the old pins, remove the old key and insert the new key. (We will assume you have already gauged the new key.) Re-pin plug and reassemble the C-clip.

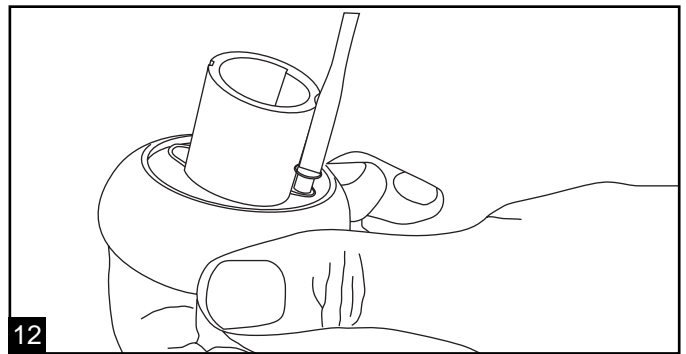

12 Place interior sleeve on top of the cylinder. Insert both screws firmly back into place.

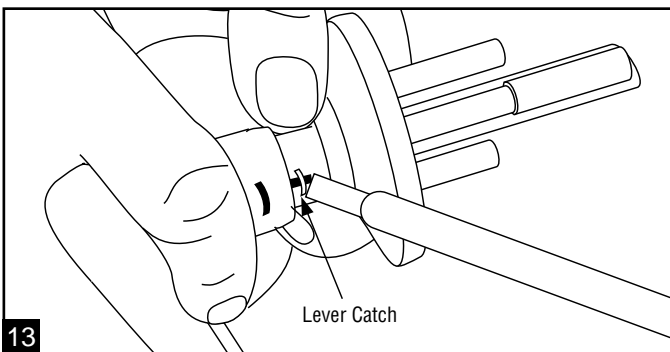

13 Place the exterior sleeve back into place.

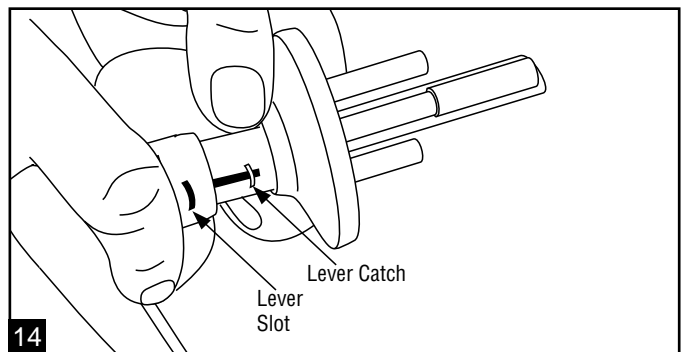

14 With spindle still in a 45 degree position, place back onto chassis.

Step-by-step instructions for:

SOCIETY BRASS
COLLECTION

Rekeying Low Profile Deadbolt with existing key

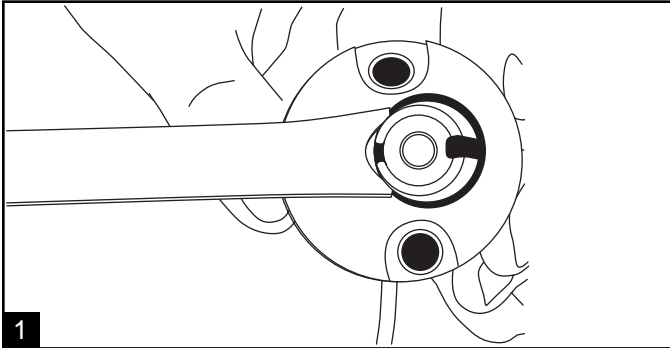

1 Remove the E-clip from the plug with the C-shaped side of your removal tool.

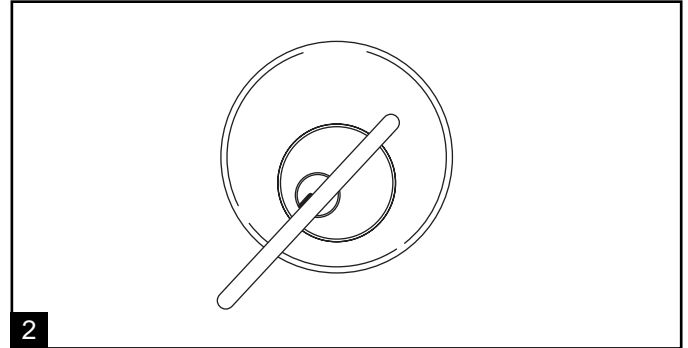

2 Turn key off vertical, so you do not allow the springs to release.

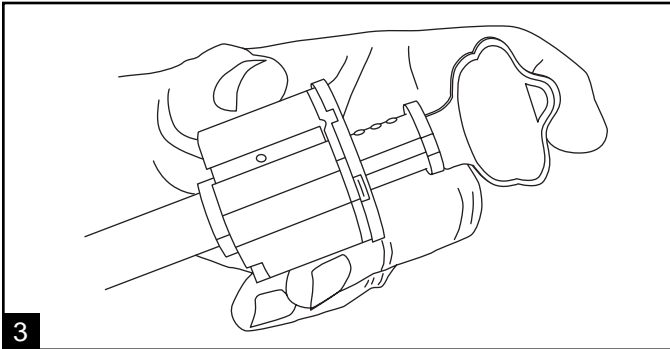

3 Use plug follower to remove plug.
(Note: The key pictured is the FINAL SBC key)

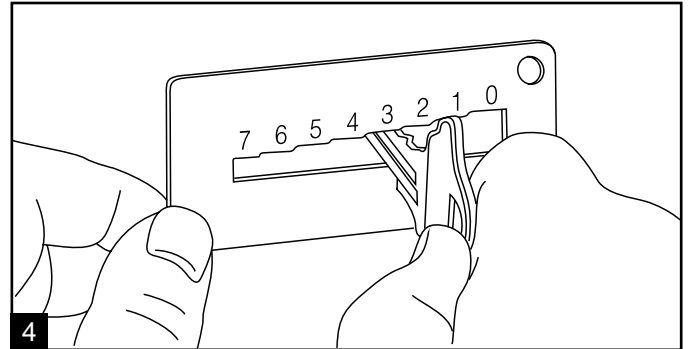

4 Gauge key and re-pin plug.

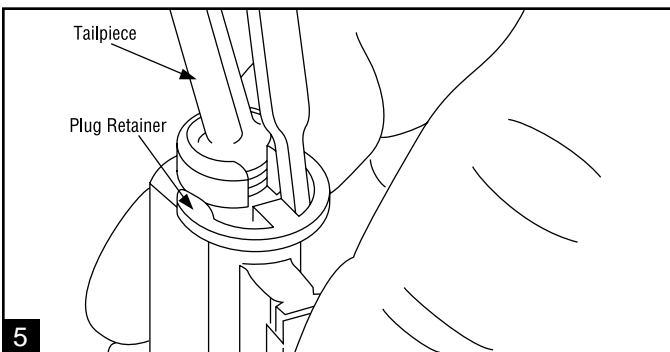

5 After re-pinning, use plug follower to slide back into cylinder then replace E-clip with tailpiece in place (if the E-clip has spread apart too far, replace with new clip from kit).

Rekeying Low Profile Deadbolt

without existing key
or if springs have fallen out

Step-by-step instructions for:
SOCIETY BRASS
COLLECTION

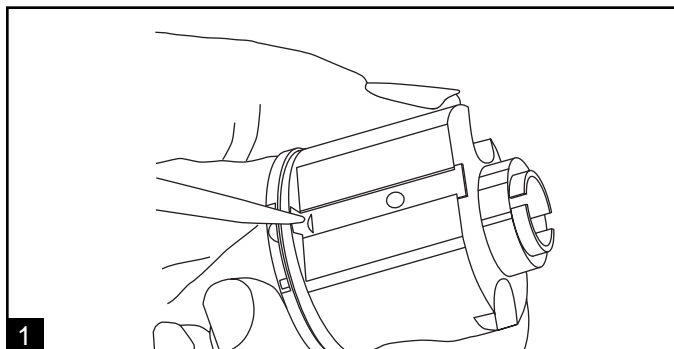

1 Slide spring cap back with awl or small slotted screwdriver.

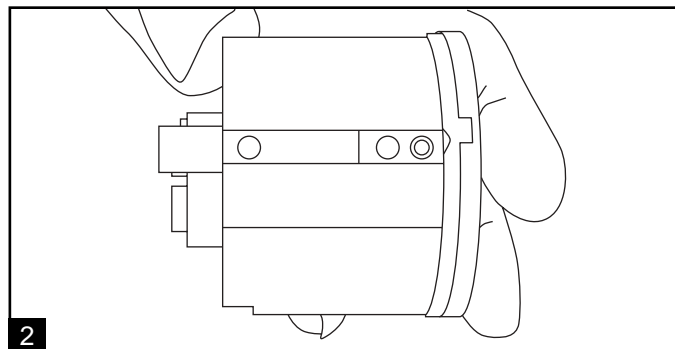

2 If you slide this slowly, your springs will not fly.

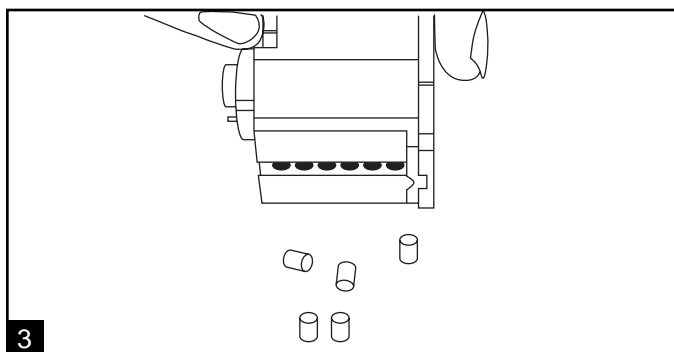

3 Remove springs and top pins, then remove E-clip and re-key plug. After replacing pins and springs, slowly slide cap back on.

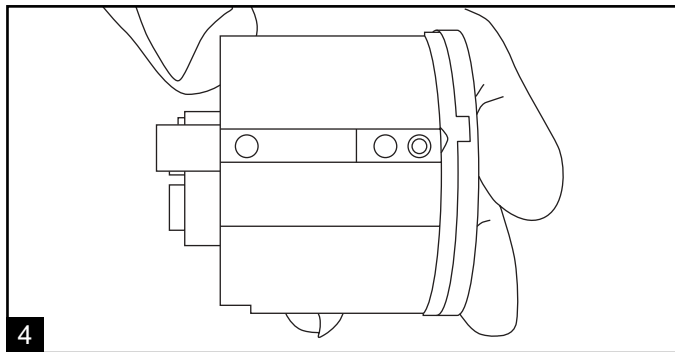

4 Load top pins (.180) and springs from top, slide spring cover back on, pressing the springs down, one at a time, with a small slotted screwdriver, as you slide cap over them.

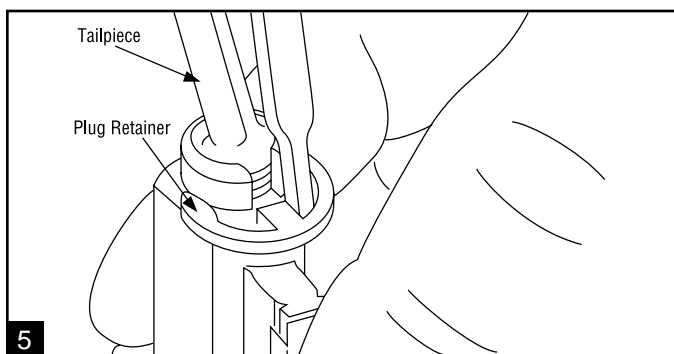

5 After re-pinning, replace plug and apply E-clip and torque blade.

Kwikset[®]

A  **BLACK & DECKER** COMPANY

Copyright © 2003 Kwikset Corporation Lake Forest, California 92610

Products and specifications subject to change without notice.

LIT 7-2-01 12/03

1-800-327-LOCK (5625)

Visit our website at: www.kwikset.com