



**SMALL FORMAT
INTERCHANGEABLE CORE
SERVICE MANUAL**

Table of Contents

Unique Qualities of CX5 Cylinders	1
Principle	1
Construction	2
Exploded View	2
Sidebar & Finger Pins	3
Operation & Hardware Installation	6
Compatibility	6
Key Blank Overview	7
Key Specifications	8
Pin Specifications for CX5 Security SFIC	8
A2 SFIC Pin Chart Specifications	9
A4 SFIC Pin Chart Specifications	10
Combining & Capping Procedures	11
Service Equipment	12
Troubleshooting	15
Interchangeable Core References	16

Note of Thanks

CX5 Security Solutions would like to thank William (Bill) M. Lynk, CRL for his considerable effort in assisting with the production of this service manual. Bill is an IC specialist and author, Certified ALOA A.C.E. instructor and ALOA content expert

Unique Qualities of CX5 Cylinders

The CX5 line of high security cylinders is a proprietary designed range of products providing outstanding quality in craftsmanship and strict policies of key control. Its unique features render these cylinders to be virtually pick resistant and bump proof. With more than 60 different **Security Groove Code** combinations per SFIC key profile and the strict adherence to control policies in key blank distribution, these products support all priorities in today's security minded environments.



Why is this core unique?

The CX5 Security Small Format Interchangeable Core (S-SFIC) was designed with added core security in mind, especially with regard to pick resistance utilizing finger pins that match a **Waved Security Groove** (side milling) on the correct key. The cores and keys are patented providing legal protection for infringement against those who attempt to produce or manufacture these key blanks. This protection allows for greater emphasis on key control, since many organizations using SFIC's encounter problems with the unauthorized duplication of keys.

Principle

The CX5 Security SFIC is similar to most SFIC's (Arrow, BEST, Falcon, Ultra, Schlage, KSP, etc.) with regard to servicing. The security sidebar does not play a role in the combining (pinning) of the core, or in the origination of the key. These two factors are determined at the factory and are of no consequence to those who must combine cores or originate keys, since the sidebar rests inside the plug of the core (unnecessary to dismantle) and the key blank with matching sidebar grooves are predetermined at the time of key blank manufacturing.

Service equipment

Pin kits (A2 or A4), tools for combining / capping and key origination remain consistent with other brands. No new equipment is necessary to service the CX5 Security SFIC.

Construction

Core configuration

The CX5 Security SFIC comes in either 6-pin or 7-pin configuration. This Patented small format interchangeable core includes the **Waved Security Groove** key technology, which offers over 60 sidebar combinations per each individual keyway configuration. Caps are of the screw-type and can be reused. Available soon will be pressed caps. Both types of caps will be able to be utilized with the CX5 Security SFIC.

Model No.:	Pins:	Keying	Finish Code
9806	6-pin	KD, KA, MK, 0-Bitted, Uncombined	10B, 26D, PVD*
9807	7-pin	KD, KA, MK, 0-Bitted, Uncombined	10B, 26D, PVD*

*Polished Brass

The cylinder plug within the SFIC contains four security finger pins. These non-spring loaded finger side pins, along with random mushroom top pins, make the CX5 cylinder virtually pick-resistant.

Exploded View

CX5 Security Small Format Interchangeable Core

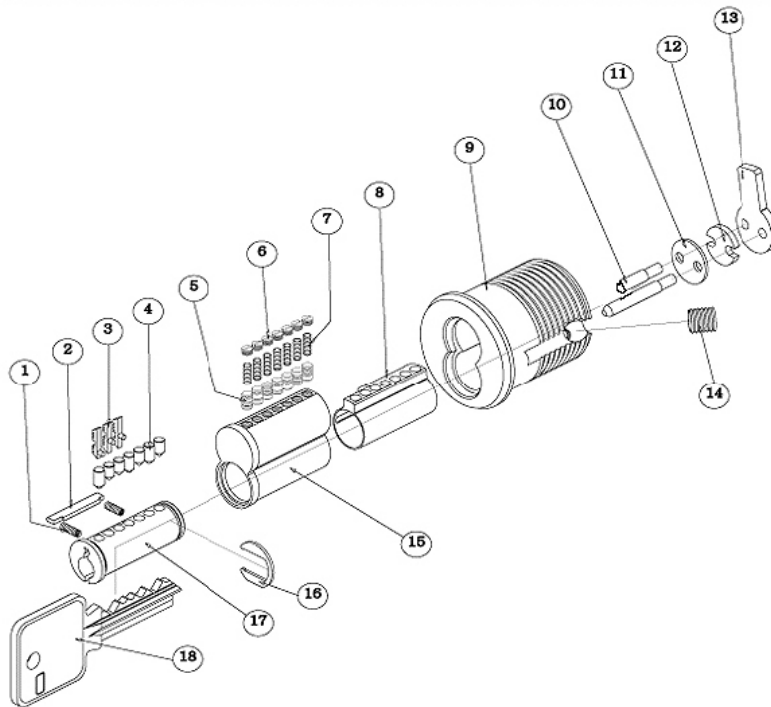

CX5 Security SFIC

NO	NAME	QTY	FINISH
1	SIDEBAR SPRINGS	2	AB
2	SIDEBAR	1	SB
3	FINGER PINS	4	ABZ
4	BOTTOM PIN	6-7	SBZ
5	UPPER PIN	21-28	SCR
6	CAP	6-7	PCR
7	CHAMBER SPRING	6-7	10B
8	SLEEVE	1	
9	MORTISE HOUSING	1	SIZE
10	THROW MEMBER	2	
11	CAM HEADER	1	
12	CAM SPACER	1	
13	CAM	1	
14	CYLINDER SET SCREW	1	
15	SHELL	1	
16	PLUG RETAINER (C-CLIP)	1	
17	PLUG	1	
18	KEY	2	

Sidebar & Finger Pins

As stated previously, there is no need to disassemble the SFIC cylinder plug from the core assembly. If, for some reason, this must be done, several cautions should be heeded.

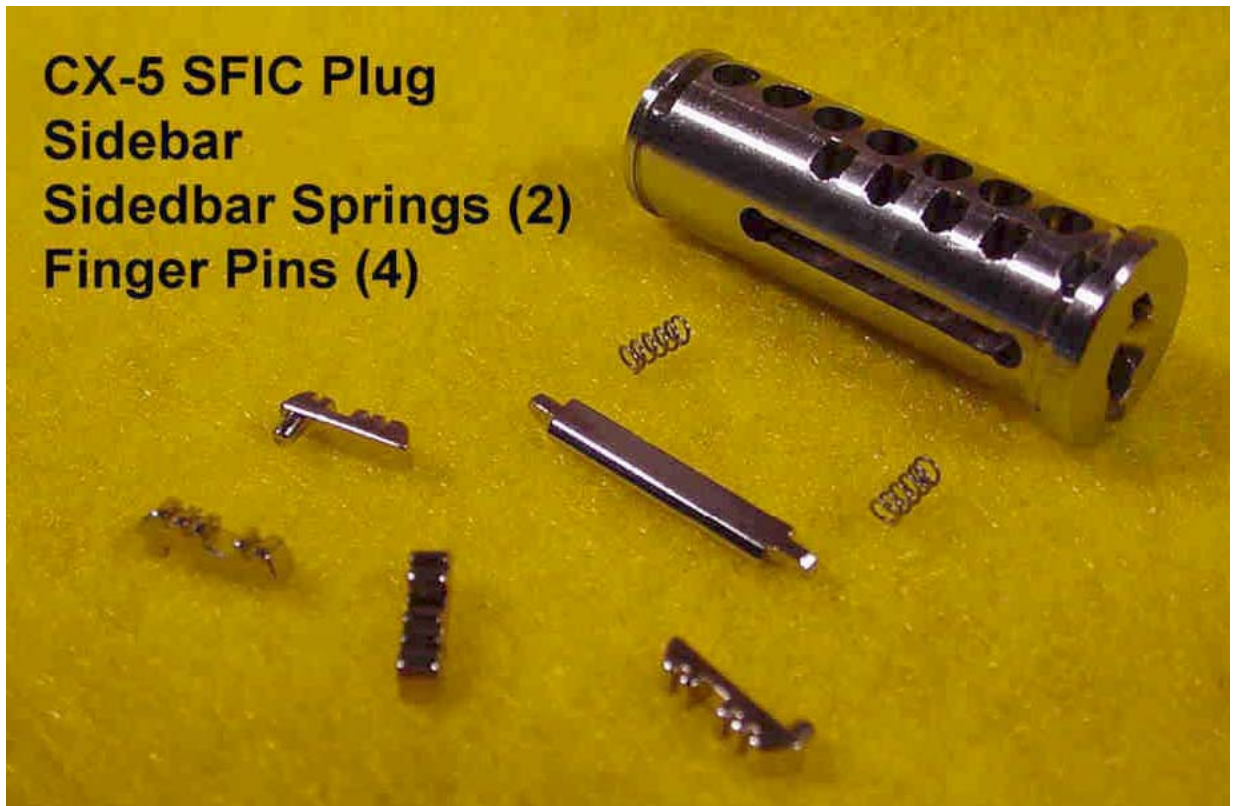

Sidebar & finger pin cautions

From the photo above, one can see that there exists four (4) finger pins within a CX5 SFIC. Note that there are five (5) within the conventional CX5 cylinders because there is more room for an additional finger pin. Within the small core assembly, room must be made for the throw member, which actuates the locking mechanism. Notice that the finger pins will have differing locations where the "open space" falls on the pin. This will match the **Waved Security Groove** (snake milling) of the key. This open space is there to accept the width of the sidebar, permitting it to retract into the plug to allow rotation.

There are two springs that push outwardly against the security sidebar. Once the plug is removed from the shell, use caution as the sidebar and springs are free to fall from the plug.

Here are the most important factors to consider if removing the plug from its shell:

Finger pin replacement procedure

1) The four sidebar finger pins are held in place ONLY if the key is in the plug. If the key is removed when the plug has also been removed the finger pins will fall out from the bottom of the plug. Replacement and realignment may be done visually.

If the finger pins fall out of the plug, you can reinsert them. Keeping in mind that each pin has a specific location, replace the first finger pin (your choice) and insert key. Make sure visually that the "open space" is visible in the sidebar area when the key is inserted. If a horizontal bar appears anywhere in the sidebar space, that particular finger pin belongs in one of the **other** positions. Remove the key and let the finger pin fall out the bottom, being ready to catch it. Continue placing that pin in another slot until the **Waved Security Groove** (snake milling) of the key matches the finger pin. Continue this process until the four pins align so the sidebar can be retracted. This should take a minimal amount of time.



2) The sidebar and its two springs will fall out if they are not held in place with the thumb and/or fingers. You may consider using the CX5 Plug Holder, shown in the Service Equipment section that follows.



3) CAUTION!!! The sidebar can be rotated (like the hands of a clock) 180 degrees with no adverse effect. However, it **CANNOT be flipped** 180 degrees (away from you)! If this is done, when the plug is reassembled, the core **will remain in a permanent locked position** and the plug cannot be removed. Thus, the core will have to be discarded as it will remain inoperable and can no longer be used.

Another key control option

The CX5 S-SFIC provides another keying advantage with its sidebar technology. Since a 7-pin key can be used to access both 7-pin and 6-pin cores of the same keyway, an alternative method of key control can be utilized. With minor shifting of the finger pin arrangement (and discarding the finger pin to the far right), 6-pin cores can be coordinated to work in conjunction with a 7-pin CX5 key.

Within a 6-pin core, a 7-pin key, with the example side milling of 1312 can operate the 6-pin core with finger pin modifications. Because the 7-pin key will not be able to be fully inserted into a 6-pin core (of the same keyway), only the first three finger pins will be used to operate the core – in this example it is 131. However, the finger pins must be shifted in order from left to right within the plug to the following pattern:

x131 (the x represents an empty finger pin position)

Key Control Alternative

using a 7-pin CX5 SFIC key in a 6-pin CX5 SFIC (same keyway)

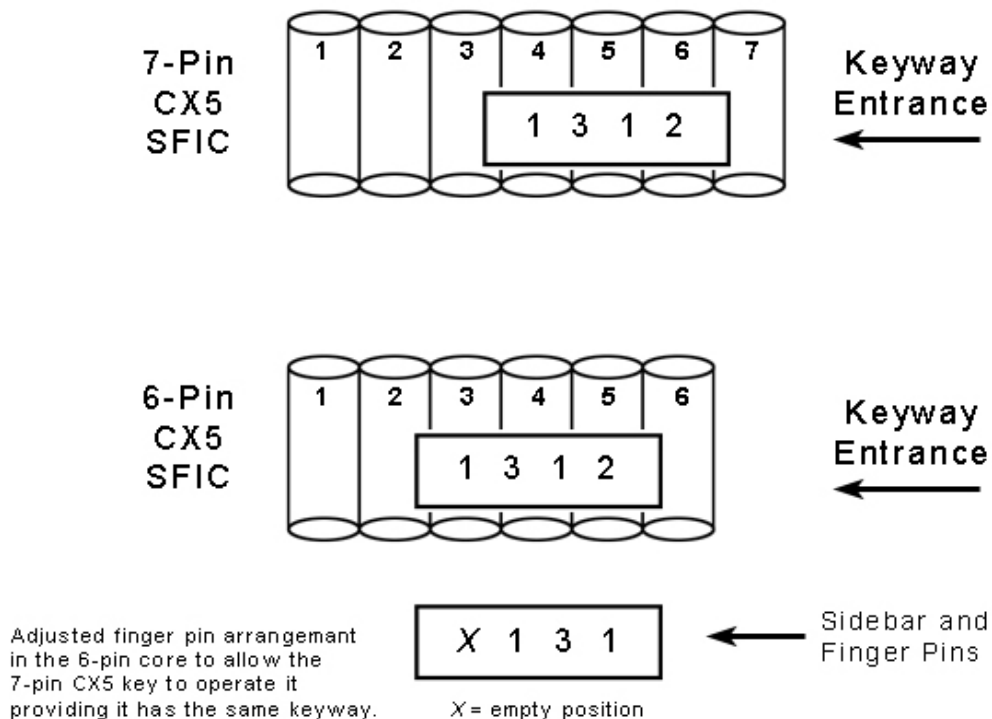

Operation & Hardware Installation

The CX5 SFIC operates similarly to that of any standard small format core. Installing the CX5 SFIC into SFIC hardware, the following two exceptions should be noted:

- ❖ When installing the CX5 SFIC into an existing mortise housing, the left throw pin must be sheared in order to accommodate the security side bar. This can be easily accomplished with the CX5 Shear Tool.
- ❖ When installing the CX5 SFIC into a leverset, use the correct CX5 tailpiece that matches the pin configuration of the core (6-pin or 7-pin).

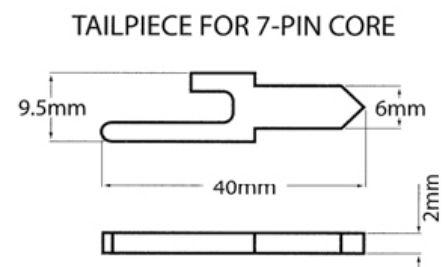
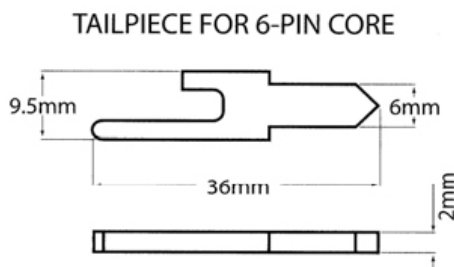

Compatibility

The CX5 Security Core can be used similarly as with any other SFIC with one exception: When using the Security core in a pre-existing IC mortise housing, one of the two throw pins must be sheared in order to accommodate the security sidebar. This is the throw pin that aligns with the security sidebar.

The CX5 Shear Tool (pictured to the right) can easily accomplish this task. It has been carefully designed to remove a small piece of the throw pin so that the core will fit properly into its mortise housing by a swift turning motion of the wrist. This tool can be utilized when installing a six or seven pin CX5 core into its respective housing, OR, when installing a 6-pin CX5 core into a 7-pin housing.



Key Blank Overview

Key blank orientation

It is generally accepted that SFIC key blanks are originated and gauged from the tip stop. Some, such as the CX5 SFIC key blank can be originated from either the tip stop or the shoulder stop, depending on the key equipment being used.

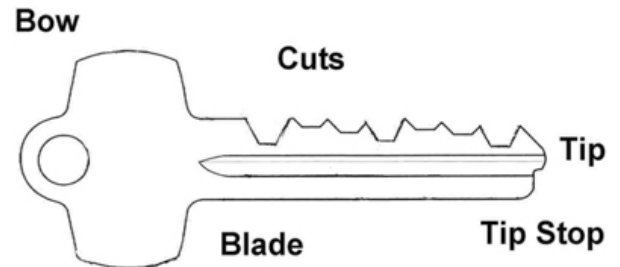

Originating/duplicating CX5 keys

Keys can be originated on standard key code cutting equipment. In addition, keys can be duplicated on any standard key duplicating machine. There exists an HPC card for those using HPC code card machines. The DSD for the HPC Blue Shark can be entered manually, using the Shoulder Stop reference. Since the side millings are factory controlled, the top bitting is all that is necessary to duplicate or originate keys.

Ordering key blanks

Distribution of key blanks is carefully managed by authorized distributors. Within the Standard Product Line, CX5 **Waved Security Groove** technology offers over 900 sidebar configurations per keyway. Each official CX5 distributor is assigned a unique sidebar configuration. Any locksmith or institution that meets required quantities may purchase an exclusive sidebar configuration. A signature card is required to permit duplication of a CX5 key.



CX-5 SFIC 9864-Key

Key blank lengths

There are two (2) key blanks available for the CX5 SFIC. Unlike most SFIC key blanks, which can be used interchangeably in either a 6-pin or 7-pin core, the specific key blank size is intended to match the CX5 core configuration, as shown:

9864-CX5.....I-Core, 6-pin CX5 Key Blank

9874-CX5.....I-Core, 7-pin CX5 Key Blank

Key Specifications

CX5 Security SFIC Key Spacing & Depth Specifications (Key gauged from shoulder stop or tip stop)

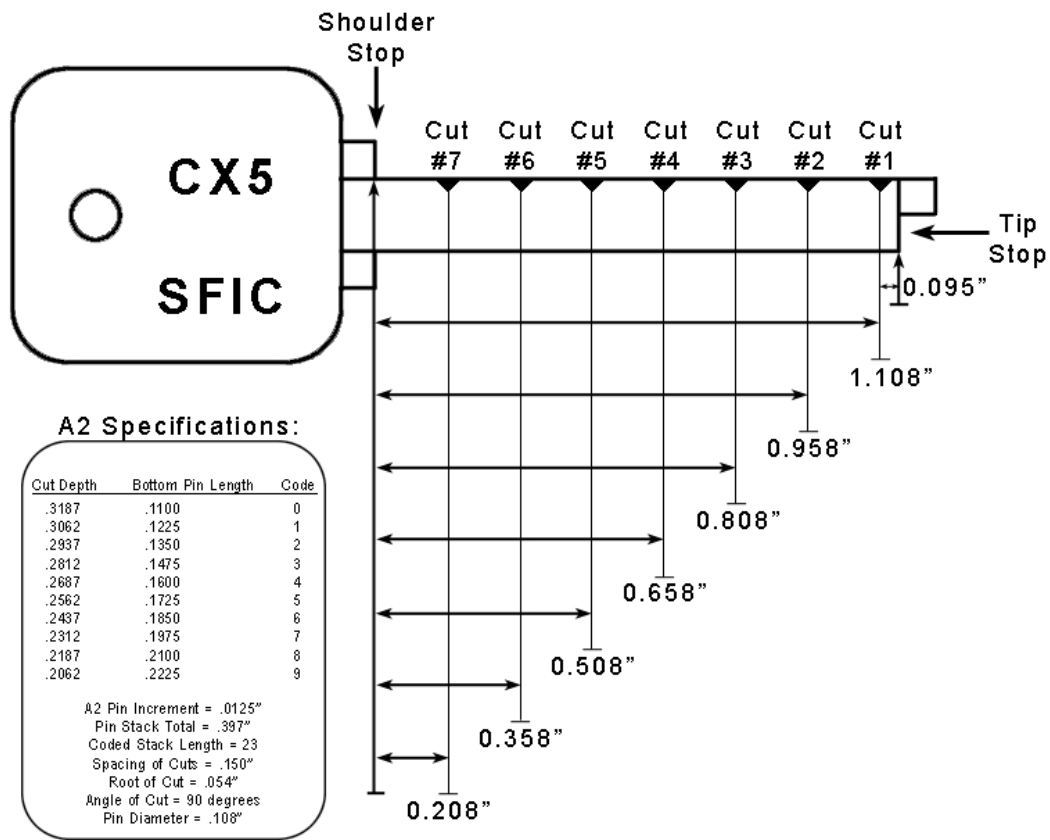

Pin Specifications for CX5 Security SFIC

Most SFIC systems follow the A2 System of pin depths created by BEST Lock Company. It is by far the most common. The A3 System was discontinued due to core failure and key interchange. The A4 System of pin depths is used especially when large numbers of key combinations are required. The A2 and A4 Systems are listed here.

When ordering combined CX5 cores from the factory, the A2 System is standard, and is the factory default when no pin increment system is specified.

A2 SFIC Pin Specifications Chart

Two-Step Master Keying System - .0125" Increments

<u>Key Depth</u>	<u>Bottom Pin Length</u>	<u>Coded Number</u>
.3187	.1100	0
.3062	.1225	1
.2937	.1350	2
.2812	.1475	3
.2687	.1600	4
.2562	.1725	5
.2437	.1850	6
.2312	.1975	7
.2187	.2100	8
.2062	.2225	9

<u>Wafer Pin Length</u>	<u>Coded Number</u>
.0250	2
.0375	3
.0500	4
.0625	5
.0750	6
.0875	7
.1000	8
.1125	9
.1250	10
.1375	11
.1500	12
.1625	13
.1750	14
.1875	15
.2000	16
.2125	17
.2250	18
.2375	19

Pin Stack Total: .397 **Decoding:** Subtract 13 minus code of top pin
Coded Stack Length: 23 **Multiplier:** Top Pin Length X 80 = Coded Length [rounded]
Cut: TIP to BOW **Root of Cut:** .054 **Angle of Cut:** 90° **Pin Diameter:** .108
Spacing (Tip to Bow from center of cut): From tip stop, each cut:
 #1 = .088 #2 = .238 #3 = .388 #4 = .538 #5 = .688 #6 = .838 #7 = .988

A4 SFIC Pin Chart Specifications

One-Step Master Keying System - .021" Increments

<u>Key Depth</u>	<u>Bottom Pin Length</u>	<u>Coded Number</u>
.318	.110	0
.297	.131	1
.276	.152	2
.255	.173	3
.234	.194	4
.213	.215	5
	<u>Wafer Pin Length</u>	<u>Coded Number</u>
	.021	1
	.042	2
	.063	3
	.084	4
	.105	5
	.126	6
	.147	7
	.168	8
	.189	9
	.210	10
	.231	11
Pin Stack Total: .404	Decoding: Subtract 8 minus code of top pin	
Coded Stack Length: 14	Multiplier: Top Pin Length X 48 = Coded Length [rounded]	
Cut: TIP to BOW	Root of Cut: .054	Angle of Cut: 90°
Pin Diameter: .108		
Spacing (Tip to Bow from center of cut): From tip stop, each cut:		
#1 = .088	#2 = .238	#3 = .388
#4 = .538	#5 = .688	#6 = .838
#7 = .988		

Combining & Capping Procedures

Combining (Pinning) the CX5 SFIC is no different than other small format cores. It is assumed that you have the bitting lists and pin segments for each chamber of every core. If you do not, you must secure this information or construct a system via mathematical calculations, slide charts, computer software or another appropriate source.

The basic combining procedure is as follows:

- 1)** Use your Ejector Pin (or Downie Pin) and line up the shear lines in the empty core. Keep the aligning tool in place in the last chamber, if you like, or the Xperinetix P3 tool to get started.
- 2)** Insert the Bottom Pin in Chamber #1 while placing core in the Xperinetix **QU-I.C Loading Block** or on suitable device. Take pin from pin kit or combining bin.
- 3)** Insert the Master Pin or Control Pin next, depending on the keying structure. If the next pin is a small wafer, you might hold the core in your hand and tilt it slightly to the side, watching the pin as it is placed so that it does not fall quickly into the hole and turn sideways.
- 4)** Insert the Top Pin.
- 5)** Check that each pin has fallen to its lowest level in the chamber and is situated flat. Use Ejector tool to push down to even out the stack.
- 6)** Test core with all keys, using the Xperinetix **QU-I.C Test Tool**, or with finger atop chambers with springs inserted [then remove springs].
- 7)** Place core into Capping Device (if individually capped).
- 8)** After slightly gently stretching spring, insert spring into chamber.
- 9)** Carefully screw on each individual Cap Cover atop each chamber.
- 10)** If the core is designed for pressed caps, use Capping Press (or Capping Tool and locksmith hammer) and tap several times so that cap is **BELOW** the flush top line of the core. BEST recommends that the cap depth be at .025" to .040" from the top of the core.

CX-5 SFIC - Top View

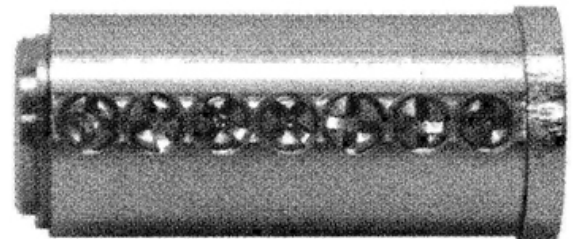

Service Equipment

There exists a plethora of excellent service equipment for the interchangeable core specialist. Because the CX5 SFIC was designed to work in conjunction with current systems, you may find the following items a valuable addition to your collection of SFIC tools and equipment – saving you time, providing efficiency and minimizing errors.

The CX5 Plug Holder is excellent for securing the sidebar while pinning or servicing the cylinder plug.

CX5 Security Solutions (866)-387-7868
www.cx5security.com

CX-5
Plug Holder

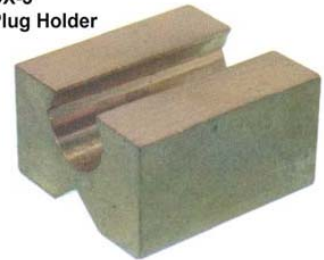

CX-5 SFIC Pin Kit



The CX5 SFIC Pin kit is available to assist in the combining of the CX5 SFIC.

CX5 Security Solutions (866)-387-7868
www.cx5security.com

The HPC Card is helpful when using HPC key origination equipment regarding the CX5 Line.

CX5 Security Solutions (866)-387-7868
www.cx5security.com

HPC Card



The CX5 Shear Tool - Allowing mortise adjustments for the CX5 SFIC.

CX5 Security Solutions (866)-387-7868
www.cx5security.com

Pro-Lok Blue Punch originates SFIC keys with accuracy and ease.

Pro-Lok (714)-633-0681

www.pro-lok.com

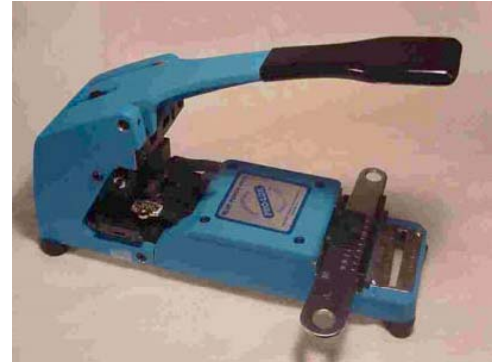

HPC's Blue Shark is the ultimate in computerized key code origination equipment.

HPC (847) 671-6280

www.hpcworld.com

The LAB IC Annex is an exceptional tool that caps cores, provides for combination & helps to decode cores. LAB also manufactures quality IC pin kits of various types.

LAB (800)-234-8242

www.labpins.com

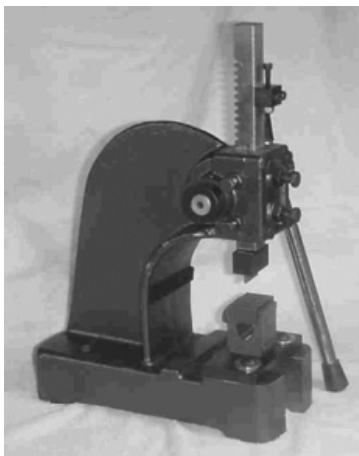
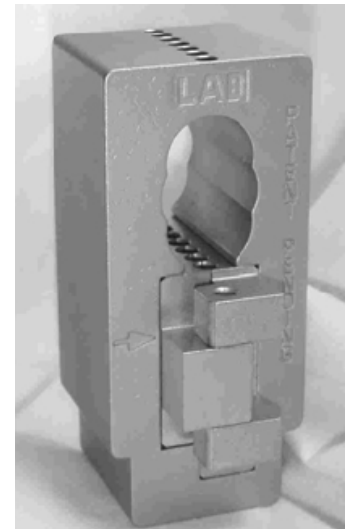

A-1 Manufacturing offers a wide array of SFIC tools, especially the Capping Press for all pressed capped cores.

A-1 (804)-359-9003

www.demandA1.com

The Henry Evers Company provides a variety of stamping tools that can assist those requiring stamping identification.

Evers (401)-781-4767

www.henryevers.com

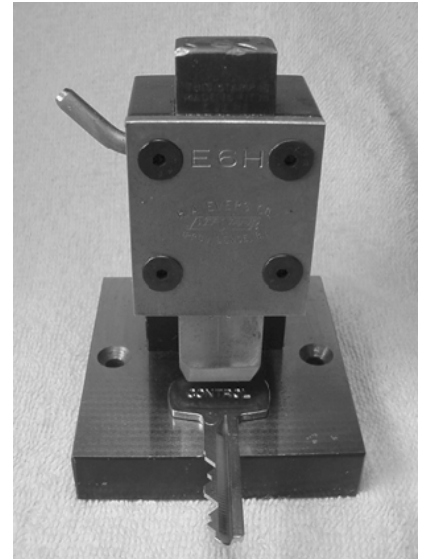

Xperinetix, through **ICLS**, offers a wide array of innovative tools for the IC Specialist. They include tools for loading, testing, checking, combining and creating SFIC systems, along with IC key control - key retainer devices (KRDs).

ICLS (313) 884-9800

www.ICLSglobal.com

Troubleshooting

Why doesn't my key rotate the CX5 plug or move the control lug?

Some of the possibilities may include that the pins were not installed correctly, a bottom pin was inserted upside down, a pin was dropped into the wrong compartment in the pin kit or the key is not the correct key for that core. Also check to see that the correct bitting was used to create the key. Double-check the key equipment for accuracy/adjustments. Make sure the key is correct. Recombinate the core. Confirm the key with a key gauge to make certain the key is cut (and spaced) properly.

My key works but it does not do so smoothly - Why?

Many of the same error checks need to be made as described in the previous concern. In addition, key wear, an improper key cut, an incorrect pin in one chamber are all possible errors.

Why won't my CX5 small core format core fit into its housing?

If using a mortise housing, check to see if one of the throw pins is shorter. If not, use the CX5 Shear Tool to correct the problem. Make certain that the throw member is aligned to accept the holes in the back of the core. Also, the mortise set screw cannot be installed too tightly. If using a tailpiece, make sure it is a CX5 tailpiece and that the correct size is used, matching the core length. Also make certain that the control lug (using the control key) is in its retracted state so that the core will be able to be inserted into its housing. Double-check that there is no foreign material in the cylinder housing, preventing the core from being inserted properly.

Why is it so difficult for me to insert/remove the key?

Sometime the key (especially the tip) may be slightly bent, thus preventing smooth operation. Check to make sure the correct keyway is being used. At times, people inserting screwdrivers or other objects into the keyway might damage the core. Have a new key made and see if that doesn't correct the problem. In some instances, improper pin stacks or even caps inserted too deeply may make key insertion/removal difficult.

Technical Support

If the troubleshooting suggestions do not solve the problem, you may contact CX5 Customer Support directly for assistance.

CX5 Security Solutions Inc.

Toll free at 866-387-7868

or

Email info@cx5security.com

www.cx5security.com

Interchangeable Core References

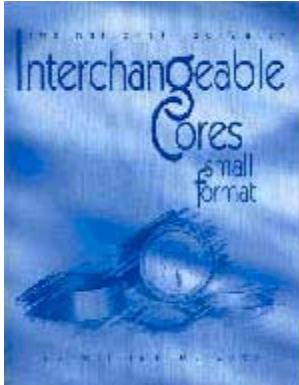

“Interchangeable Cores: Small Format”, ©2000 by William M. Lynk/TNL, has now become a standard in the international market! This book covers everything you need to know about how to service, sell, install and troubleshoot small format I-Cores. Learn the basics in an easy-to-understand (and sometimes humorous) format that is excellent for beginning locksmiths or those new to the SFIC world. Forget about the problems with math and all the specifics, William Lynk, an IC Specialist for 30 years, explains it all in a way that is fun to learn. Chapters include: Terminology, IC Advantages, Blanks, Tools, Removing Cores from Stubborn Shells, Decoding Cores, Pinning, Record Keeping, Installing & Planning a System, Master Keying, Billing/Pricing and Tips for Success. Each chapter has a quiz, including a Final Exam to help reinforce your understanding. There are over 140 pages of priceless information designed to make I-Core work quick, easy and profitable! This book is a valuable addition to anyone's library,

“Removable Cores: Large Format” ©2003 by William M. Lynk/TNL, is packed with exploded views, photos, diagrams, pictures, charts, line art, drawings and various graphics, that will aid the reader in understanding and in solving individual RC problems on your job site! Written by an IC Specialist who has been working with cores since 1974, why worry about Sargent, Kaba, Schlage, CorbinRusswin, Medeco or Yale again??? Get this book and have an up-to-date resource at your fingertips. Each chapter is dedicated to a single manufacturer (with Chapter Quizzes) and was created under the auspices of the six major core manufacturers, namely: **Yale, CorbinRusswin, Medeco, Schlage, Kaba and Sargent**. This was a cooperative milestone, which became a “first” for the competitive lock manufacturers, and coordinated by Bill Lynk! The book was written and then each chapter was submitted to the respective manufacturer for accuracy and comments. But.....if you are only interested in ONE particular manufacturer for your current job...excellent!! This book, all 240 pages with Final Exam, is organized *[with a superb index]* just for you! You can look up what you need to know and then move on.....allowing for accurate and fast information delivery. This book is a 'must have' and is essential in understanding and properly servicing the popular large format interchangeable core.

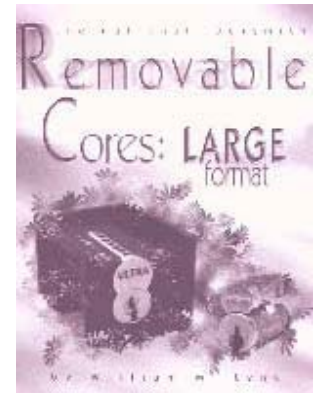

“SFIC: Advanced” ©2005 by William M. Lynk/TNL is *THE* book for anyone who has worked on or now works with SFICs on a regular basis. A true break-through in the SFIC arena, this comprehensive 309-page collection contains never-before printed information on keyway profiles, graphic pin segments for all systems, a new IC pin chart, master keyed control key lists, and much, much more! This revolutionary book includes 249 crisp digital photos, 58 easy-to-read charts, 112 superb diagrams (with exploded views) and even nine exams to test your knowledge! Review SFIC original patent diagrams along with historical information, previously only shared with a select few. In addition, this is the most complete, up-to-date assembly of SFIC tools anywhere, coupled with detailed information on creating, decoding and servicing existing and NEW types of SFIC systems. This virtual "*Encyclopedia of SFIC*" was written by one who teaches IC for ALOA, locksmith associations and security conferences nationally. Absolutely everything you need to know is here.....so, don't miss out on an easy way to increase your sales with the help of this SFIC gem!

Books Available through:

National Publishing Company/The National Locksmith: (630) 837-2044 in Chicago, Illinois
The Associated Locksmiths of America (ALOA): (214) 827-1701 in Dallas, Texas