

CodeMax[®]

Computerized Code Cutting Machine

No. 1200MAX

No. 1200MAXAA

Exploded View
&
Parts List Inside



© 2013 HPC, Inc. • Schiller Park, IL • 60176 • USA • www.hpcworld.com

041013 36012_000_00

The CodeMax[®]

Computerized Code Key Machine



This manual and the internal software and data of the CodeMax[®] described in this manual are copyrighted by:

HPC, Inc., Schiller Park, Illinois, U. S. A.

The internal software and data is a work fully protected by the United States Copyright Laws.

Federal Law: This manual or the internal software of the CodeMax[®] may not be copied, translated, photocopied, microfilmed, or reproduced in any manner to be machine readable in any form (in whole or in part), without the express written consent of the copyright holder.

HPC, Inc.
Schiller Park, Illinois
Copyright 2008



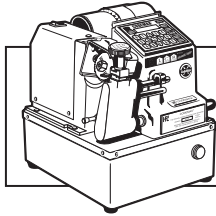

Visit the CodeMax® web page at www.hpcworld.com/km/codemax to learn about your machine.



Look For...



Watch Our Other Videos

To watch the videos showing the important features of the CodeMax®.

Look For...



Features of the CodeMax®

To learn the features of CodeMax® Version 10 (Upgrades are available).

Look For...



Depth & Space Data

To view or download the current list of DSD numbers and the key cutting details for each one.

Look For...

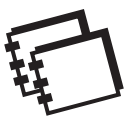

Manuals and Exploded Views

To view or download a PDF of the CodeMax® Operation Manual.

Look For...



Exploded Views

To access the Exploded View and Parts List to identify a spare part needed.

Look For...



Key Machine Accessories

To see the accessories that are available for your CodeMax®.

Index

1. Introduction	4
1.1 Product Packaging Checklist	5
1.2 Parts Designation	7
1.3 Preparation of the CodeMax®	8
1.4 Basic Codemax Setup	9
1.5 Emergency Button	10
2. Cutter Wheels	11
2.1 Cutter Wheel Descriptions	11
2.2 Changing Cutters	12
2.3 Resharpener Cutters	14
3. Holding And Gauging Keys	15
3.1 Vise Jaws	15
3.2 Key Gauges	19
3.3 Gauging Methods	19
3.3.1 Standard Cylinder Key With Shoulder Gauge Using Jaw A	19
3.3.2 Standard Cylinder Key With Shoulder Gauge Using Jaw B	21
3.3.3 Red Full Short Tip Stop Gauging Using Jaw A	23
3.3.4 Red Middle Short Tip Stop Gauging Using Jaw A	24
3.3.5 Black Horseshoe Tip Stop Gauging Using Jaw B	25
3.3.6 Medeco® – Standard Commercial Jaw Using Jaw C (optional equipment)	26
3.3.7 Black Horseshoe Full End Tip Stop Gauging Using Jaw A or B	27
4. Key Cutting Methods	29
4.1. Stand Alone Key Cutting	30
4.1.1 Standard Keys	30
4.1.2 Medeco® Keys	32
4.1.3 After The Key Has Been Cut	35
4.1.4 Additional Notes	36
4.2 Computer Assisted Key Cutting	37
4.3 Micrometer Key Cutting	39
5. Recalibration Of The CodeMax®	43
5.1 Electronic Calibration	43
5.1.1 Depth Instructions	44
5.1.2 Space Instructions	46
5.1.3 DSD Specific Instructions	48
5.2 Manual Calibration	50
Space Calibration	50
5.2.1 Cutting Too Close To The Tip On Keys Gauged From The Tip	51
5.2.2 Cutting Too Far From The Tip On Keys Gauged From The Tip	53
5.2.3 Cutting Too Far From The Shoulder	55
5.2.4 Cutting Too Close To The Shoulder	57
5.3 Depth Adjustment	59
6. Updates	60
7. Troubleshooting	61
8. Glossary	62
9. Exploded Views	64
10. Preventive Maintenance, Lubrication, Repairs, and Guarantee	68



1. Introduction

Thank you for purchasing this CodeMax[®] Machine; we appreciate your business.

The CodeMax[®] represents the latest development in the industry's first computerized code machine. Utilizing cutting edge technology, this version allows for electronic calibration, DSD modification, and updates installed by your computer.

Please read this manual to become familiar with the features and operation of your CodeMax[®]. This machine is updated every year with new information and features. Please complete and return the enclosed warranty registration card to ensure you receive notice of future updates.

We are confident your CodeMax[®] will provide years of service for you. If you have any questions or comments about this machine (or any HPC products), please contact us.

Thank you,

HPC, Inc.
3999 N. 25th Avenue
Schiller Park, Illinois 60176
U.S.A.
Tel: 847.671.6280
Toll-free in U.S.A. and Canada: 800.323.3295
Fax: 847.671.6343
Email: hpc@hpcworld.com
www.hpcworld.com

1.1 Product Packaging Checklist

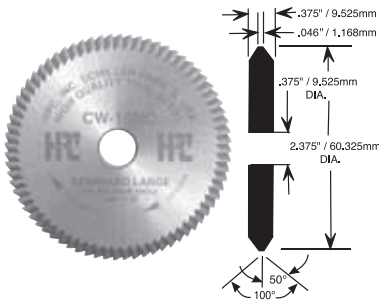

HPC Cutter Wheel (installed)
(CW-14MC)

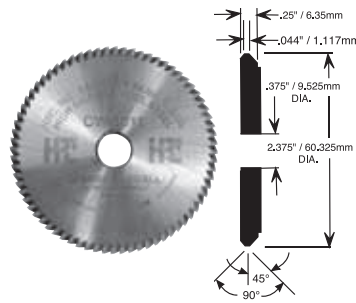

HPC Cutter Wheel
(CW-1011)

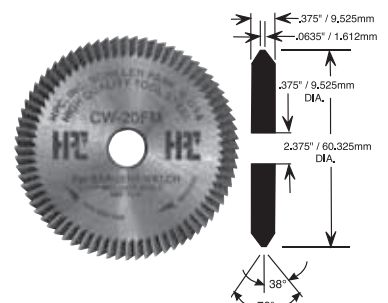

HPC Cutter Wheel
(CW-20FM)

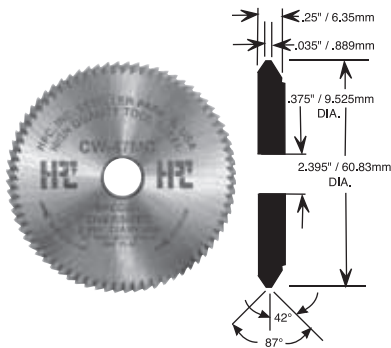

HPC Cutter Wheel
(CW-47MC)

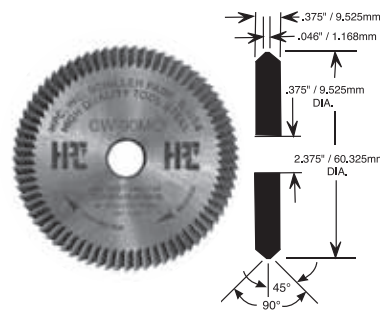

HPC Cutter Wheel
(CW-90MC)



Cutter Wrench
(WRENCH-3)



Allen Wrench, 5/64"
(WRENCH-2)



Cutter/Adjustment Wrench
(WRENCH-1)



Red Tip Gauge
(CM-1054MA)

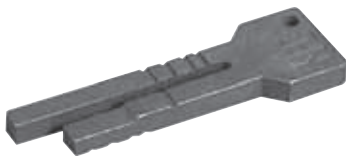

Horseshoe Tip Gauge
(CM-1054R)



DSD List
CodeMax® Update &
Restore CD
(MAX-CD)

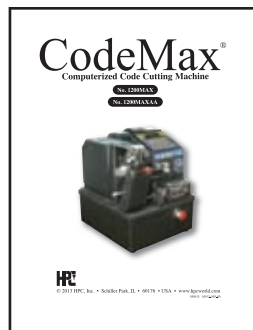

CodeMax® Manual
(1200MAX-MAN)



Serial Cable
(CABLE-25S)

Your CodeMax® computerized code machine comes with the following additional items (see the photos on the previous page):

<i>Qty.</i>	<i>Stock No.</i>	<i>Description</i>
1	CW-14MC	HPC Cutter Wheel (Installed on Machine)
1	CW-1011	HPC Cutter Wheel
1	CW-20FM	HPC Cutter Wheel
1	CW-47MC	HPC Cutter Wheel
1	CW-90MC	HPC Cutter Wheel
1	WRENCH-1	Cutter Shaft/Adjustment Wrench
1	WRENCH-3	Cutter Nut Wrench
1	WRENCH-2	Allen Wrench, 5/64-inch
1	CM-1054R	Black Horseshoe Tip Gauge
1	CM-1054MA	Red Tip Gauge
1	MAX-CD	DSD List, CodeMax® Update and Restore CD
1	1200MAX-MAN	CodeMax® Manual
1	—	Warranty Registration Card
1	CABLE-25S	Serial Cable

1.2 Parts Designation

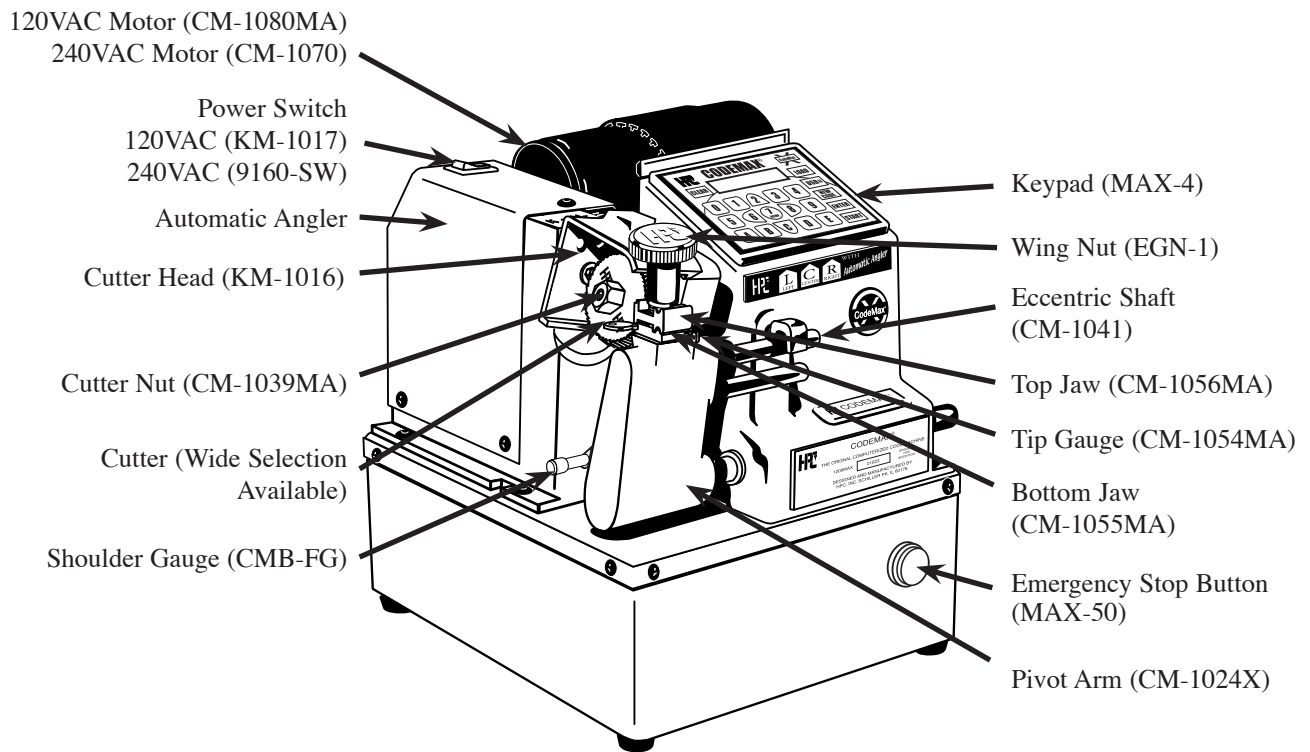

1.3 Preparing To Use The CodeMax® Computerized Key Machine

Before using the CodeMax® key machine, read this manual in order to gain a thorough understanding of all of its capabilities. You will receive peak performance and efficiency from your machine by fully comprehending all of its functions.

Make sure that the power outlet that the CodeMax® will attach to is properly wired, i.e., grounded with correct hot and neutral leads. If the outlet is not wired properly or power from the available outlet is not regular (i.e., you experience frequent power brownouts), the CodeMax® may malfunction. While the CodeMax® contains an internal surge protector, it is recommended that you also use an external surge/brownout protector when operating the CodeMax®.

1.4 Basic CodeMax® Setup

Find a suitable location for the CodeMax® machine. This should be an area with good ventilation for the cutter motor and easy access to the front and top of the machine for use and cleaning.

Plug the cord into the back of the CodeMax® and then into the appropriate electrical outlet. Turn on the CodeMax® using the switch located at the left rear of the machine.



The display will read “Emergency Stop Depressed”. Make sure there is nothing interfering with the pivot arm, cutter wheel, and motor. Push the large, red emergency stop button located at the front of the CodeMax® until it pops out.

The CodeMax® will go through a brief test routine to prepare itself for use. The CodeMax® display will read “CodeMax Ready”, indicating that the machine is in its main screen and ready for use.

CODEMAX®

**CodeMax Ready
HPCSoft Version 10.0**

1.5 The Emergency Stop Button

The CodeMax® has an emergency stop button installed.

Pushing the emergency stop button at any time will immediately freeze the operation in which the machine is engaged. For example, if you started the cutting process and realized you had the wrong cutter or key blank, pushing the emergency stop button would instantly turn off the cutter motor and stop the pivot arm from traveling.

To reset the CodeMax®, after the machine freezes, push the emergency stop button until it pops out, and the machine will return to its Home Position. Make the necessary adjustments (e.g. put the shoulder gauge down, or install the correct cutter or key blank), and start the key cutting process again.



**Note: When the emergency stop button is pushed, the CodeMax® will clear the bittings entered, if the bittings were entered directly on the CodeMax® keypad.*

If you have any questions, please call the HPC Service Dept. 1-800-323-3295.

2. Cutter Wheels

2.1 Cutter Wheel Descriptions

The model CodeMax® is supplied with five standard cutter wheels. The CW-1011 cutter is used for cabinet, padlock, and most vehicle applications. The CW-14MC cutter is used for cutting most standard cylinder keys. The CW-90MC is similar to the CW-14MC but makes cuts with a steeper slope for special applications. The CW-20FM cutter is a 76 degree cutter used for Sargent applications. The CW-47MC is an 87 degree cutter used for certain automotive applications.

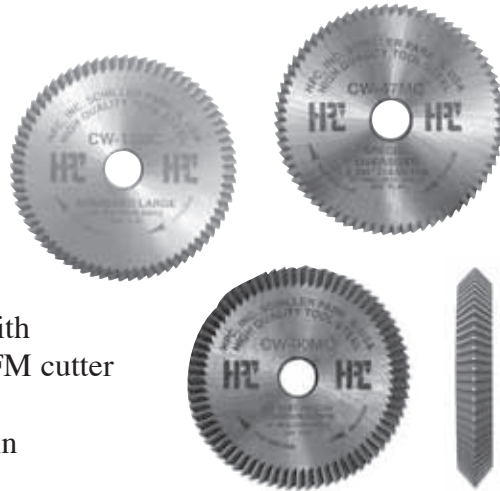

Flat steel cutters, the Medeco® cutter (CW-1012), the Emhart cutter (CW-1013), and the Assa Cutter (CW-32MC) are all optional cutter wheels that are available for use with the CodeMax®. Additionally, the Medeco® Commercial Jaw (MJ-1) is an optional jaw for cutting the Medeco® Standard Commercial Keyway (Air). The KeyMark® Jaw is available from Medeco®.

2.2 Replacing Cutter Wheels

The following procedure is recommended when changing cutters:

IMPORTANT NOTE: Be sure the cutter is installed for a clockwise rotation, with the arrow facing the outside, so it can be seen.

- 1) Turn the CodeMax® off.



- 2) Hold the cutter shaft with the 1/2 inch end of WRENCH-1.

- 3) Loosen the cutter shaft nut with the 3/4 inch WRENCH-3 by turning it clockwise (left hand thread). The cutter shaft is threaded with reverse, left-hand thread.

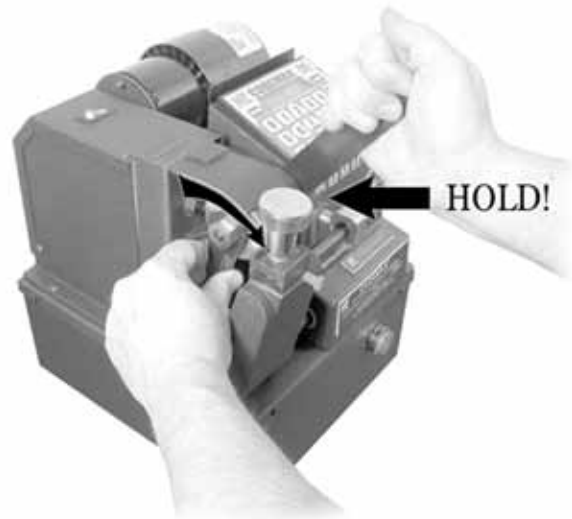

- 4) Remove the cutter. Slide the replacement cutter onto the shaft.



IMPORTANT NOTE: Be sure the cutter is installed for a clockwise rotation, with the arrow facing the outside, so it can be seen.



- 5) Hold the shaft with the 1/2 inch WRENCH-1.

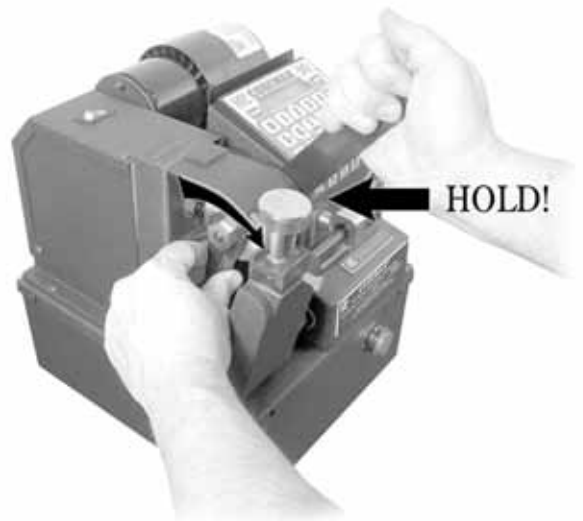

- 6) Install the nut, turning **counterclockwise** onto the cutter shaft with the 3/4 inch wrench.
Do not overtighten the nut!

2.3 Resharpener Cutter Wheels

One of the most important features of the CodeMax® is its capability to maintain correct depth and spacing with virtually no setup time involved, including the changing of the cutter wheels. This capability is dependent upon the use of cutters whose outside diameters are carefully calibrated. We recommend using only HPC cutter wheels.

Eventually, cutters become worn and should be replaced. We do not recommend sharpening cutters. The diameter of a resharpened cutter is smaller and will therefore make cuts shallower if no depth adjustment is made. See Depth Adjustment Section (5.2) for further information.

In order to maintain matched cutter diameters, all cutters for the CodeMax® must be resharpened at the same time to account for material lost during this process.

3. Holding And Gauging Keys

The CodeMax[®] comes from the factory calibrated and ready to cut keys to manufacturers' specifications. The necessity for special gauges and adapters has been held to a minimum. Basically, one upper Vise Jaw, which is removable and reversible, covers the greatest range of key cutting. This upper Vise Jaw (CM-1056MA) is marked "A" on one side and "B" on the other. When the A side is in use, the letter "A" faces up, in sight of the operator. The B side is in position when the "B" is seen. Manufacturers' data and information about the corresponding jaws can be found on the DSD-CD.

3.1 Vise Jaws

Jaws A & B – Standard Jaws (CM-1056MA) Installed

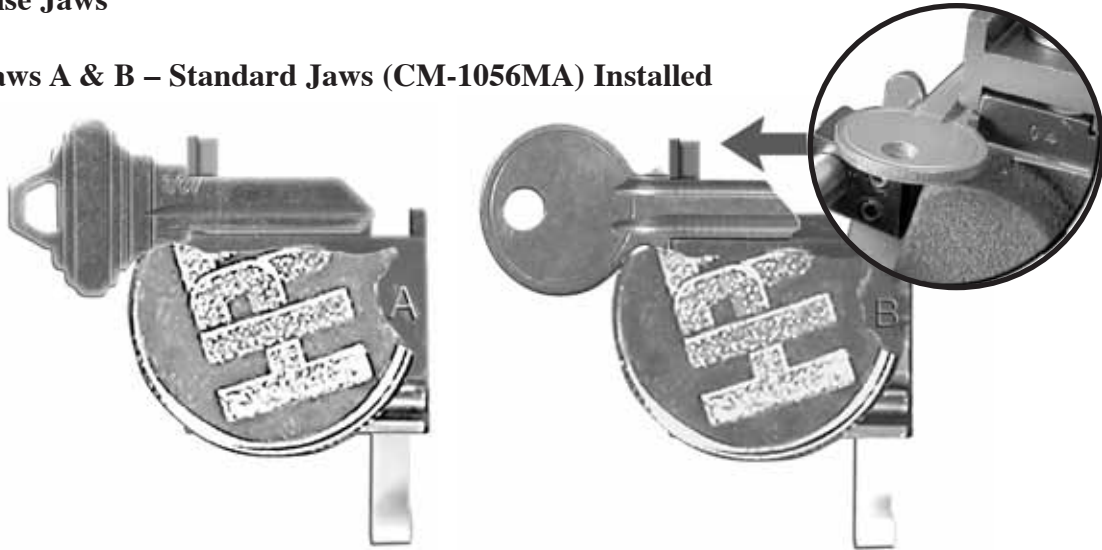

Fig. 1A. Properly seated key in jaw A.

Fig. 1B. Properly seated key in jaw B.

Vise jaw A is used for all standard keys with the deepest cut no less than .142 inches (see Fig. 1A). Jaw B is used for small keys that use cuts of such great depth that a lip on the jaw is provided to hold the key closer to the cutter. See Fig. 1B.

Some keys (Best[™] for example) will tip when using Jaw A. If there is a problem holding the key in Jaw A, use Jaw B by placing the lip of Jaw B on the edge of the blank. The blank must still be positioned at the back of the bottom jaw. See Fig. 2.

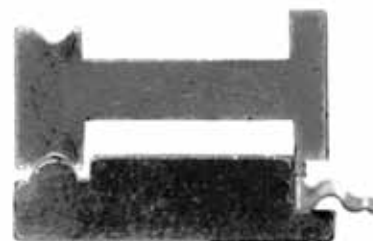

Fig. 2.

Jaw C – Medeco® Jaw (MJ-1) Optional Equipment Required For Cutting Medeco® Keys (Not Required For Biaxial Keys)

Shoulder Gauge

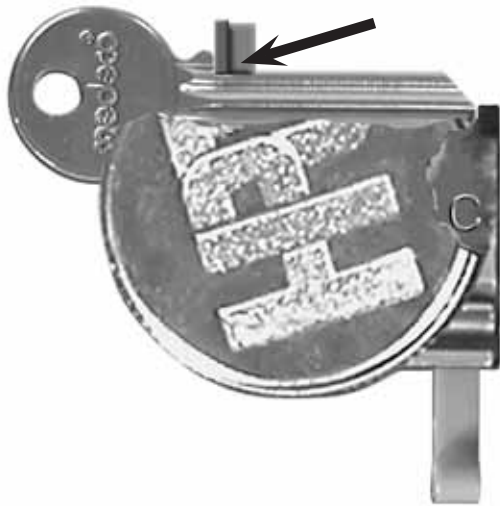

Fig. 3A.



Fig. 3B. Properly seated key in jaw C.

An optional cutter (CW-1012) and Jaw C (MJ-1) are required to cut commercial level Medeco® keys. Both parts are readily available from your HPC distributor. Biaxial keys only require the CW-1012 cutter, not MJ-1.

The optional Jaw C is a specially milled CodeMax® jaw. It is required for holding the standard Medeco® keys (see Fig. 3A). Vise Jaw C is milled to fit and firmly nest into the Medeco® commercial key grooves. The proper and firm grip provided by Jaw C is necessary due to the extremely deep cuts used on Medeco® keys. Instructions for using Medeco's KeyMark® Jaw are available from Medeco®.

Gauge the key from the shoulder, making sure the key grooving and special jaw milling are nested together (see Fig. 3B).

3.2 Key Gauges

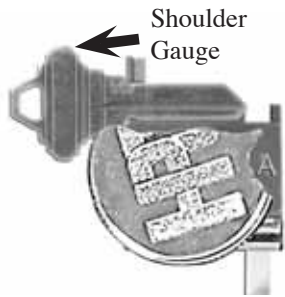

Fig. 4

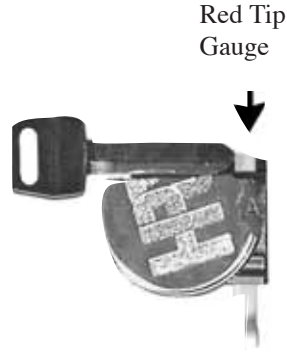

Fig. 5

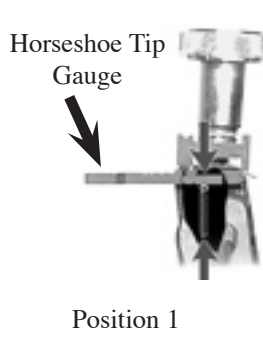

Fig. 6

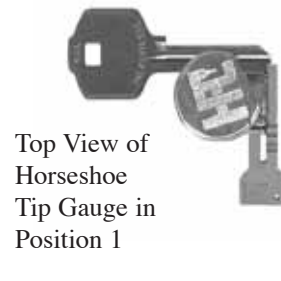

Fig. 7

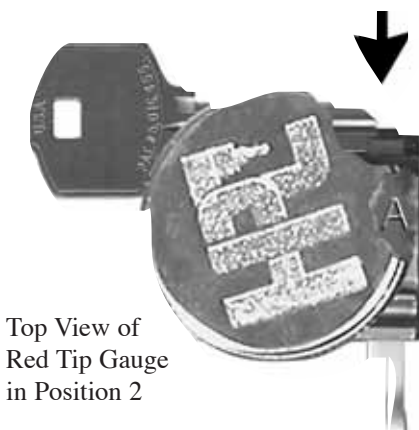

Fig. 8



Fig. 9

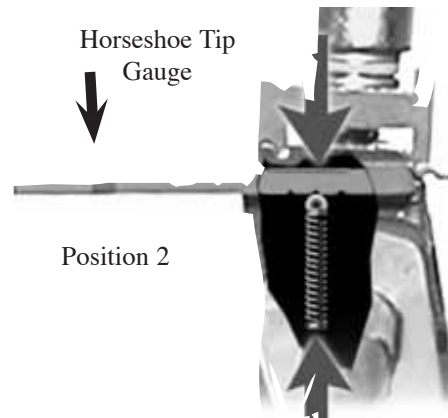

Fig. 10

Keys with shoulders are gauged by placing them squarely into the vise assembly and swinging the key Shoulder Gauge (CMB-FG) upward. The key is moved laterally, as required, until the key's shoulder just touches the left hand surface of the gauge (see Fig. 4).

Note: Be sure to tighten the wing nut and swing the Shoulder Gauge back down before starting the cutting process.

Keys without shoulders are properly gauged by using the Red Tip Gauge (CM-1054MA) or the black Horseshoe Tip Gauge (CM-1054R). The bottoms of these tip gauges have several grooves, allowing them to be held in different positions by a spring loaded ball bearing. These tip gauges are pulled back to the first position where they are held within the base of the lower jaw (Figs. 5 & 6) safely out of the path of the cutting wheel.

See Figs. 7, 8, 9, & 10 for tip gauge references.

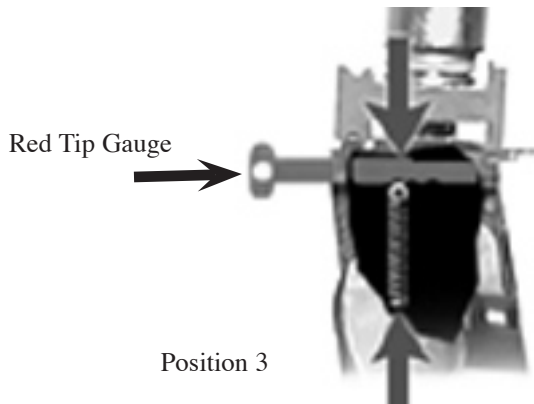

Fig. 11.

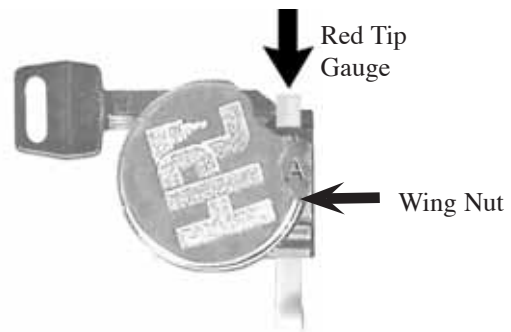
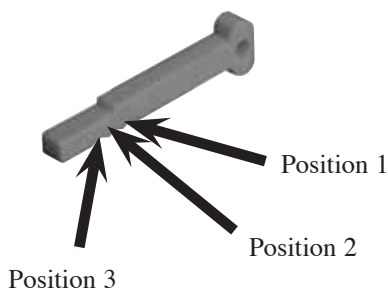

Fig. 12. 5 Pin Ford.

In the third position, the Red Tip Gauge is sent forward into the third groove and this is the proper setting for old, 5-pin Ford keys (see Figs. 11 & 12). To clamp and gauge double sided Ford type keys, the offset of the key is set against the face of the jaw. Slide the key to the right until the tip butts against the tip gauge and tighten the wing nut. The blank is held off the key rest by this method, thereby eliminating the need for any special blocks (see Figs. 11 & 12).



Red (Plastic) Tip Gauge (CM-1054MA)

Position 1: Out of the way
 Position 2: Best
 Position 3: Ford

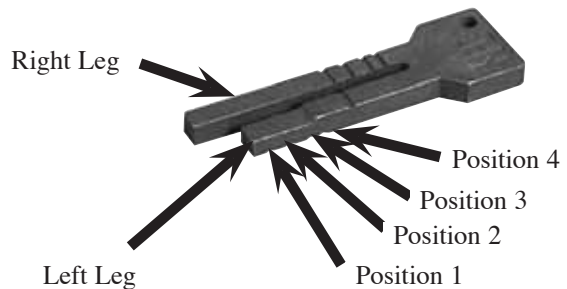

(Black) Horseshoe Tip Gauge (CM-1054R)

Position 1: Best – Right Leg
 Position 2: Ford – Right Leg
 Position 3: Best – Left Leg (same as 2 red)
 Position 4: Ford – Left Leg (same as 3 red)

Note: Red Tip Gauge should be pulled back to position 1 or removed when cutting shoulder gauged keys.

Remove Black Horseshoe Tip Gauge completely when gauging or cutting shoulder gauged keys or when gauging from positions 3 and 4 prior to cutting.

Positions 1 and 2 of Horseshoe Tip Gauge are designed to bring the tips of key blanks even with the right side of the jaw. If the right leg is bent inward (so the tip gauge doesn't enter the jaw) or bent outward (so key blanks gauge beyond the right side of the jaw) the right leg should be gently tapped back into alignment.

3.3 Gauging Methods

3.3.1 Standard Cylinder Key With Shoulder Gauging Using Jaw A (Example: Schlage, DSD #60)

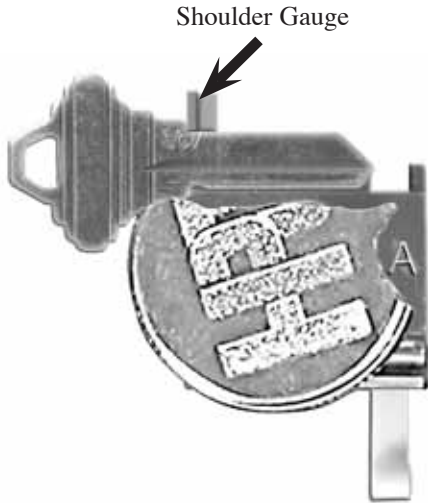

- 1) Place the key blank in Jaw A. Raise the Shoulder Gauge to its upright position. Position the key blank with the shoulder of the key lightly touching the left hand edge of Shoulder Gauge (avoid undue pressure – see Note below).

Note: The spacing of the key cuts can be significantly affected by any damage incurred to the Shoulder Gauge. Handle the Shoulder Gauge with care! Damage to the Shoulder Gauge most often occurs when the gauge comes in contact with the cutter, or when undue pressure is used when gauging against the key's shoulder. Make sure to gently position the key blank against the Shoulder Gauge to avoid damage.

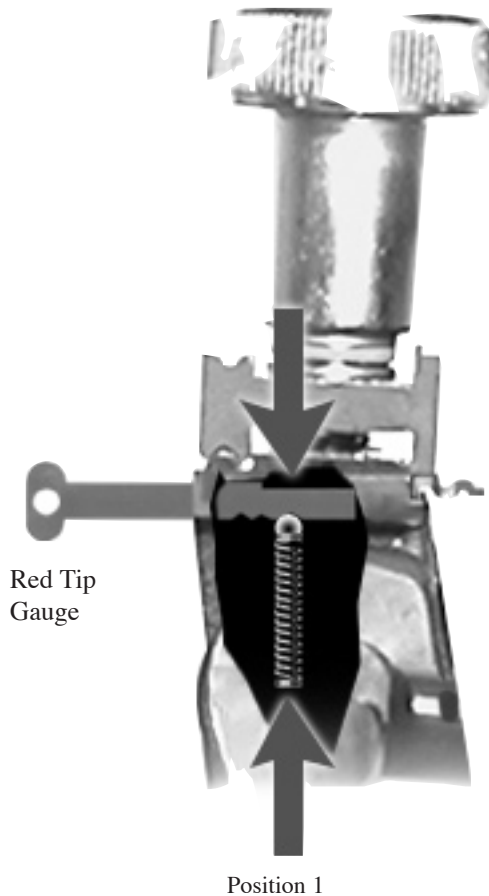

- 2) Make sure the Tip Gauge (if installed) is out of the way. The Red Tip Gauge is pulled to the rear and safely in the detent position (Position 1) before continuing, and the Horseshoe Tip Gauge is removed.

- 3) Tighten the Wing Nut and flip the Shoulder Gauge down before continuing.

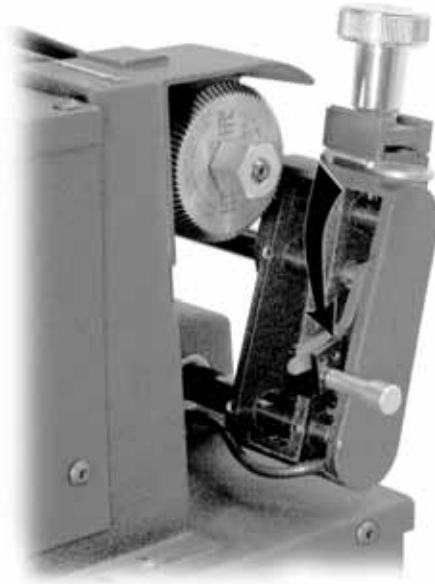
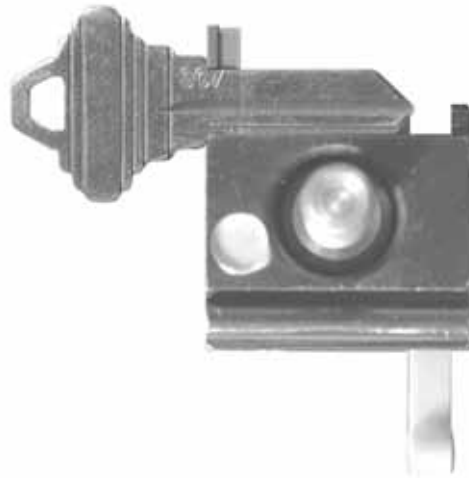
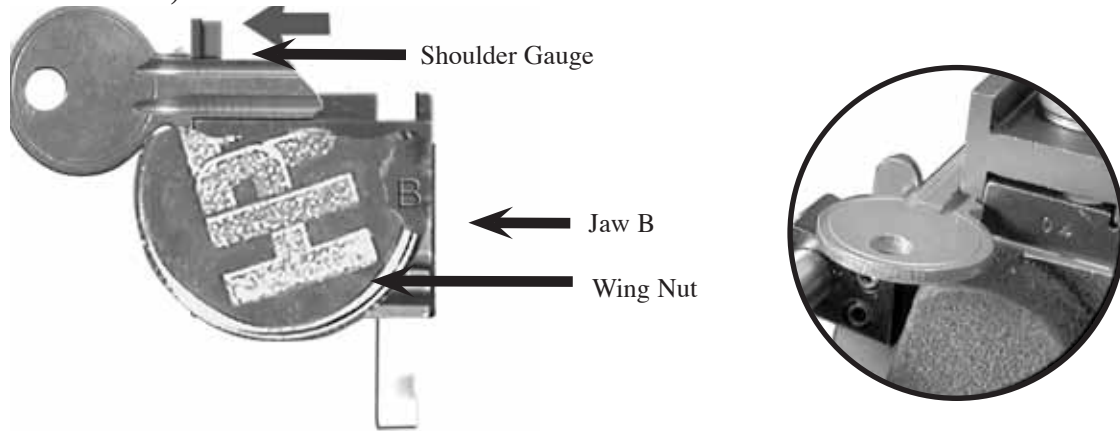

Fig. 4. Wing Nut and Top Jaw of vise removed to show top view of the Bottom Jaw only, for key positioning.

- 4) Make sure the key is lying flat against the back of the Bottom Jaw before tightening the Wing Nut.



3.3.2 Standard Cylinder Key With Shoulder Gauging Using Jaw B (Example: Master, DSD #49)



- 1) Place the key blank in Jaw B. Make sure that the key lies in front of the lip, and flat against the lip. Raise the Shoulder Gauge to its upright position. Position the key blank with the shoulder of the key lightly touching the left hand edge of Shoulder Gauge (avoid undue pressure – see Note below).

Note: The spacing of the key cuts can be significantly affected by any damage incurred to the Shoulder Gauge. Handle the Shoulder Gauge with care! Damage to the Shoulder Gauge most often occurs when the gauge comes in contact with the cutter, or when undue pressure is used when gauging against the key's shoulder. Make sure to gently position the key blank against the Shoulder Gauge to avoid damage.

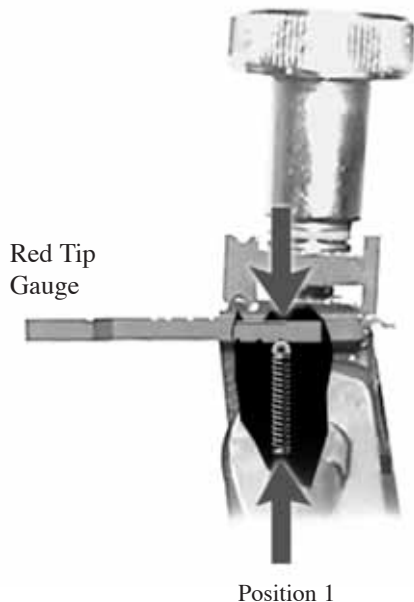

- 2) Make sure the Tip Gauge is completely out of the way, and that the Horseshoe Tip Gauge is removed.

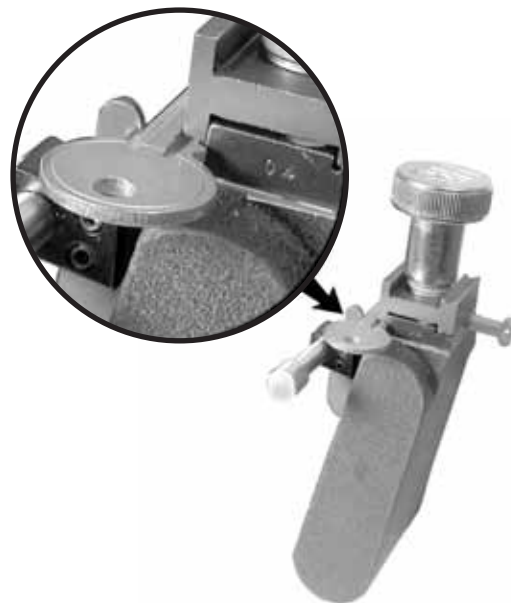

- 3) Make sure that the key lies in front of the lip, and flat against the lip.

- 4) Tighten the Wing Nut and flip the Shoulder Gauge down before continuing.

Wing Nut

Shoulder Gauge
in the Down Position

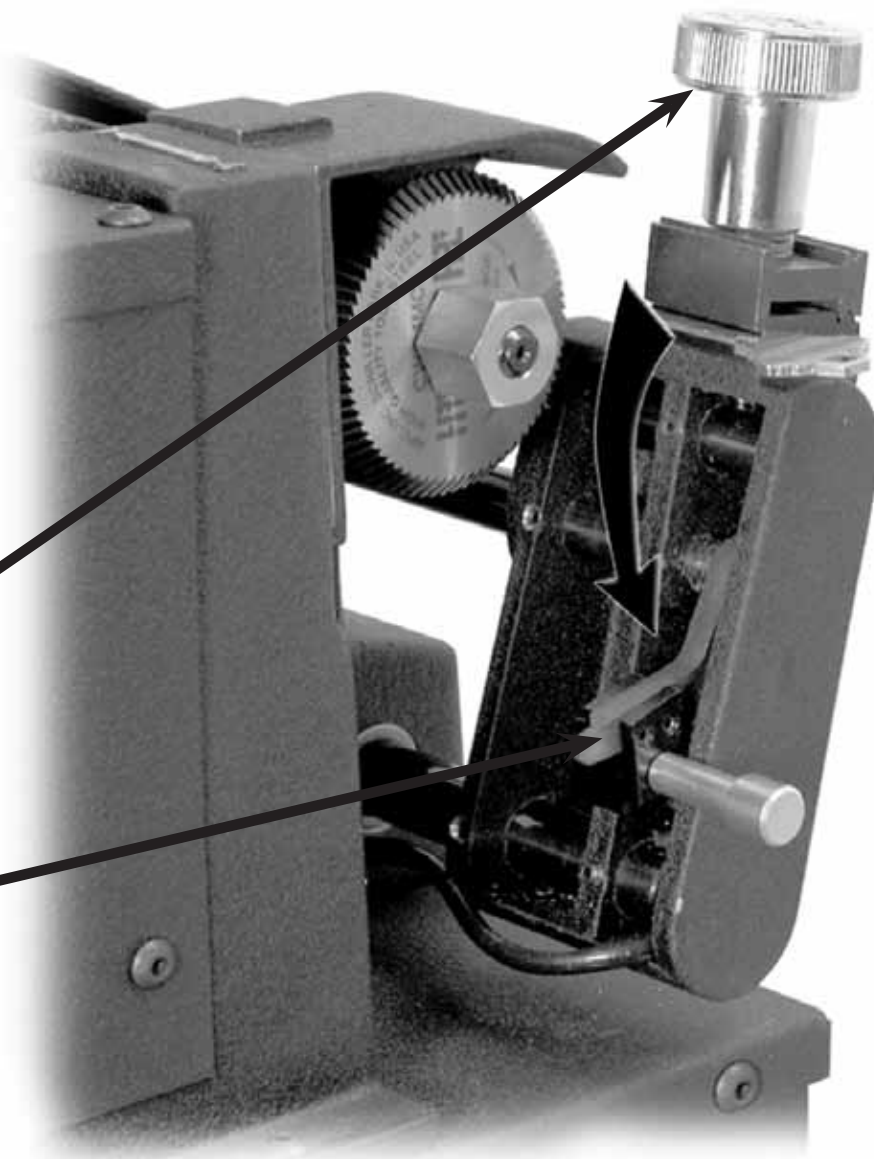

3.3.3 Red Tip Gauge In Position 3 (Full Short Tip Stop) Using Jaw A (Example: Ford, DSD #34)

- 1) The Red Tip Gauge is pushed inward to position 3.

Note: Make certain to pull the Tip Gauge to the rear (position 1) before cutting.

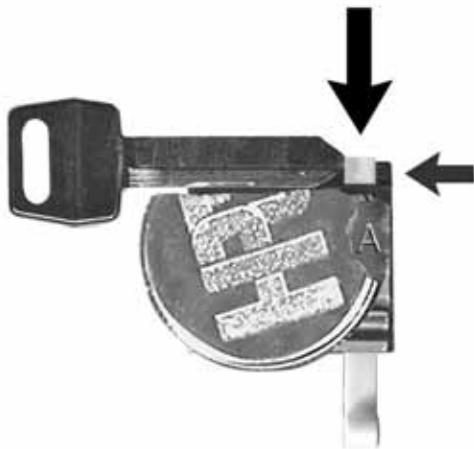
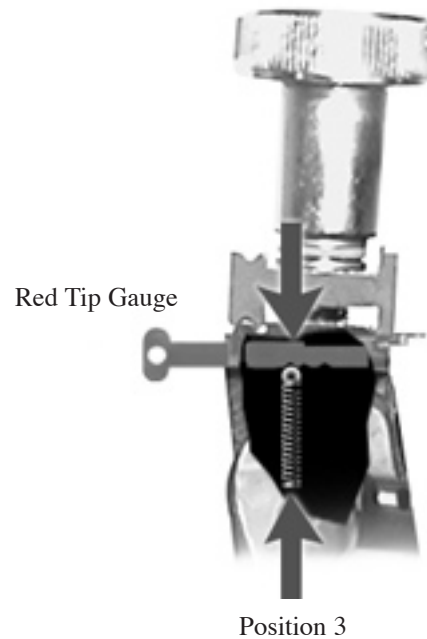

- 2) The key is gauged from the tip. Make sure the Shoulder Gauge is lowered before continuing.



Fig. 3. The Wing Nut and Top Jaw of the vise removed to show a top view of the Bottom Jaw only, for key positioning and Tip Stop settings.

- 3) Make sure the blank is lying flat on the ledge against the back of the Bottom Jaw before tightening the Wing Nut.

Note: For Ford blanks (DSD#34), the key blank grooving edge lies directly on the face of the jaw for ignition and trunk keyways. No riser blocks are used.

3.3.4 Red Tip Gauge In Position 2 (Middle Short Tip Stop) Using Jaw A (Example: KABA-PEAKS 6-Pin, DSD #608)

- 1) The Red Tip Gauge is pushed inward to Position 2. The Tip Gauge is pulled to the rear (position 1) while cutting.

Note: Make certain to pull the Tip Gauge to the rear (position 1) before cutting.

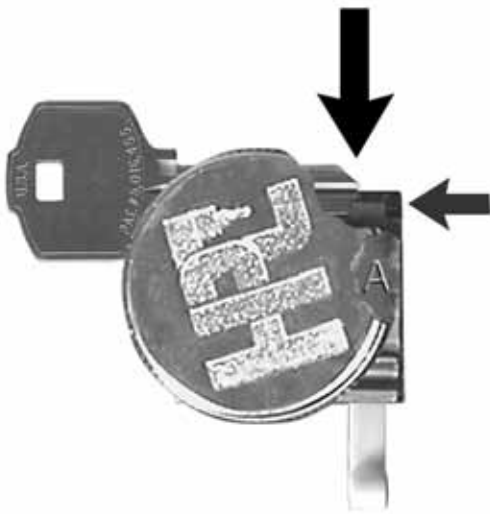
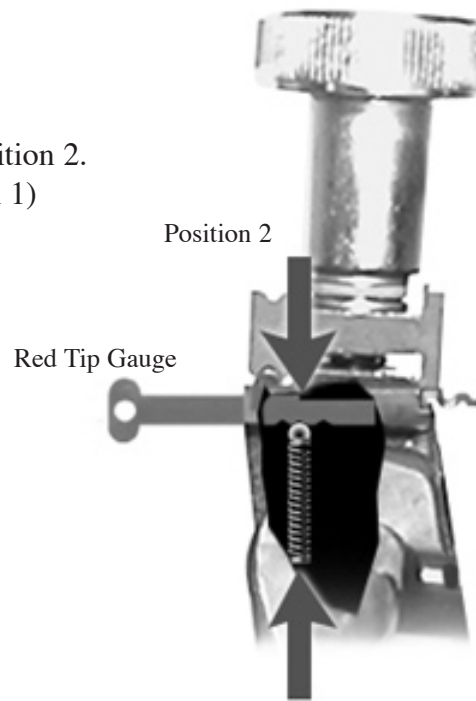

- 2) The key is gauged from the bottom stop, not the tip.

- 3) Be sure the key lies flat against the back edge of the Bottom Jaw before tightening the Wing Nut.

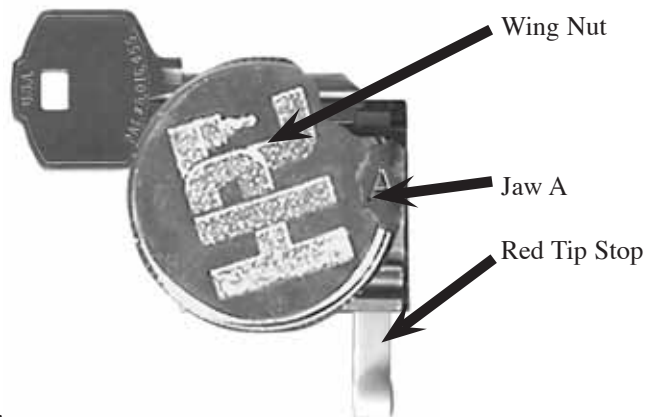

Fig. 3. The Wing Nut and Top Jaw of the vise partially removed to show a top view of the Bottom Jaw only for key positioning and Tip Stop settings.

3.3.5 Black Horseshoe Tip Gauge In Position 1 (Short Tip Stop) Using Jaw B (Example: DSD #3)

- 1) The Tip Gauge is pushed inward to position 1.



Horseshoe Tip Gauge

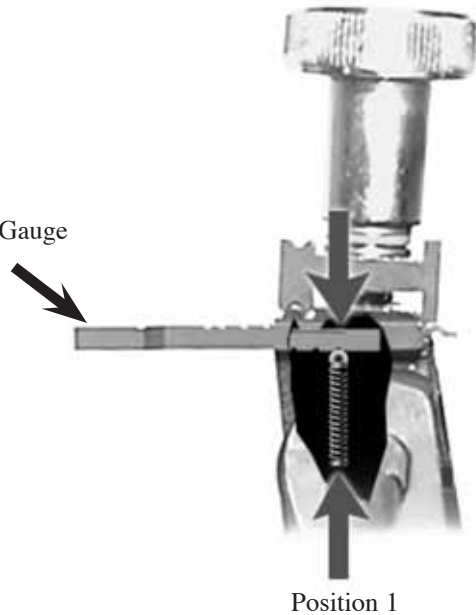

Position 1

- 2) The key is gauged from the bottom stop of the key, not the tip.

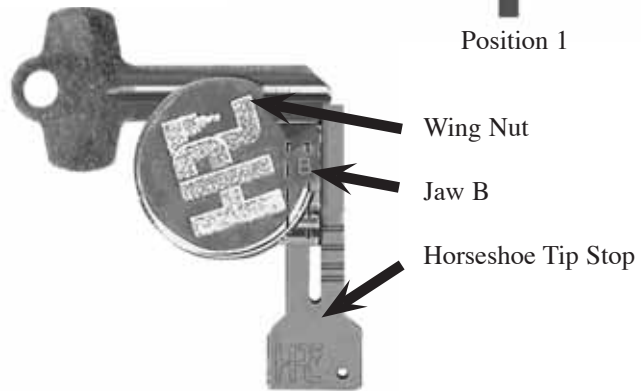
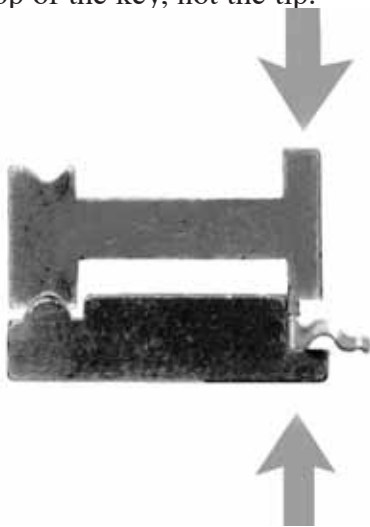

Wing Nut

Jaw B

Horseshoe Tip Stop

- 3) Slide the key to the right until the bottom stop of the key touches the right leg of the Horseshoe Tip Stop. Be sure the key lies flat against the back edge of the bottom jaw before tightening the wing nut.

Note: Undue pressure against the right leg will cause the legs to spread, resulting in inaccurately cut keys.

- 4) Note the special holding on the key milling using Jaw B. (The key must be lying flat against the back ledge of the Bottom Jaw as shown.)

3.3.6 Medeco® Standard Commercial Key Using Jaw C (Optional Equipment) With Shoulder Gauging (Example: DSD #51)

- 1) The key shoulder touches the left hand edge of the Shoulder Gauge. Avoid undue pressure – see note below.

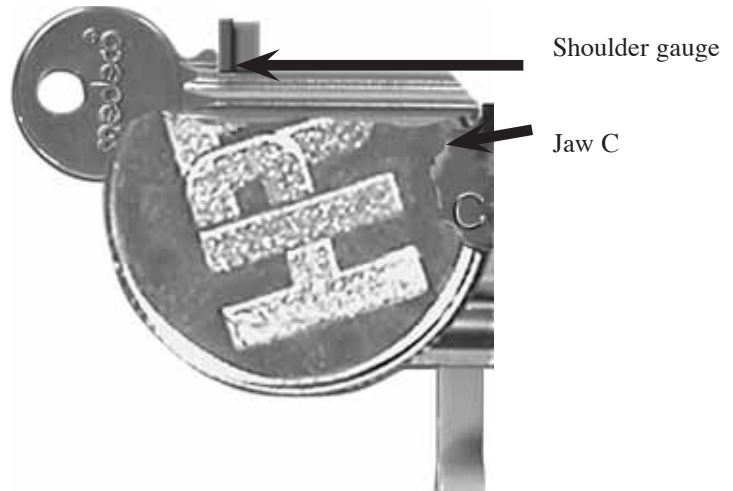

Note: The spacing of the key cuts can be significantly affected by any damage incurred to the Shoulder Gauge. Handle the Shoulder Gauge with care. Damage to the Shoulder Gauge most often occurs when the gauge comes in contact with the cutter, or when undue pressure is used in gauging against the key's shoulder. Make sure to gently position the key blank against the Shoulder Gauge to avoid damage.



The jaw and key grooves “nest” into each other. The Tip Gauge (if installed) is pulled back to the rear to position 1 (Horseshoe Tip Gauge is removed). Open Jaw C only enough to slide the key into position. Be sure the key groove and jaw milling mate before tightening the Wing Nut.

- 3) Flip the Shoulder Gauge down and tighten the Wing Nut before proceeding.

Medeco® is a registered trademark of Medeco Security Locks, Inc.

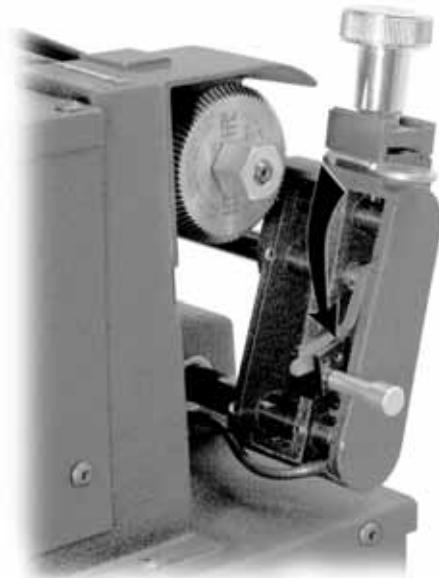

3.3.7 Black Horseshoe Tip Gauge In Position 2 Using Jaw A or B (Example: GM Modular 94+, DSD #259)

- 1) The Horseshoe Tip Gauge is pushed inward to position 2.

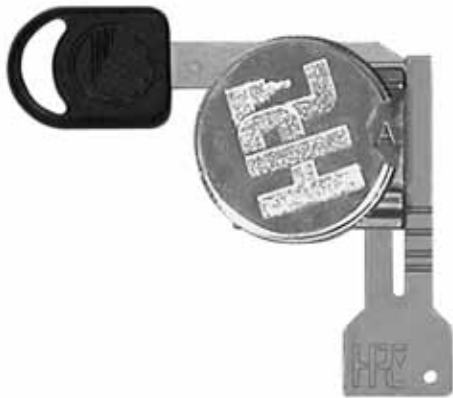
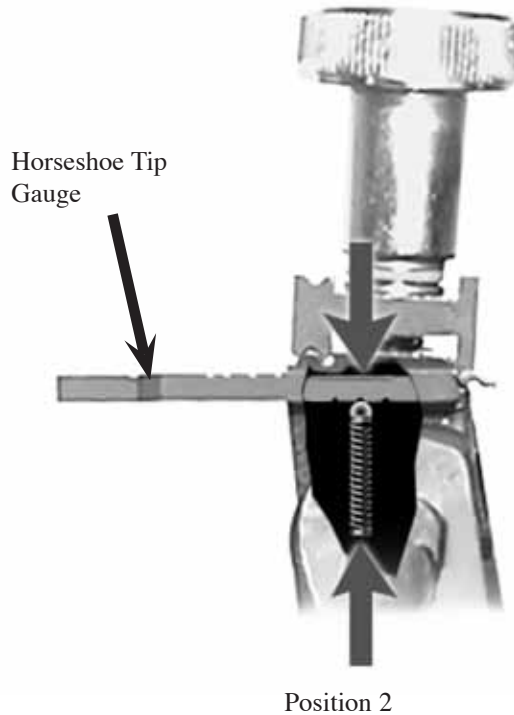

- 2) The key is gauged from the tip as shown. Be sure the key lies flat against the back of the Bottom Jaw before tightening the Wing Nut. Lower the Shoulder Gauge.

Note: Undue pressure against the right leg will cause the legs to spread, resulting in inaccurately cut keys.

Note: On Ford blanks (DSD's 35 and 261) the key blank grooving edge lies directly on the face of the key vise. No riser blocks are used.

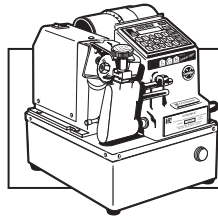

Visit the CodeMax® web page at www.hpcworld.com/km/codemax to learn about your machine.



Look For...



See it in use!

To watch the videos showing the important features of the CodeMax®.

Look For...



Features of the CodeMax®

To learn the features of CodeMax® Version 10 (Upgrades are available).

Look For...



Depth & Space Data

To view or download the current list of DSD numbers and the key cutting details for each one.

Look For...

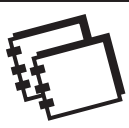

Manuals and Instructions

To view or download a PDF of the CodeMax® Operation Manual.

Look For...



Exploded Views

To access the Exploded View and Parts List to identify a spare part needed.

Look For...



Key Machine Accessories

To see the accessories that are available for your CodeMax®.

4. Key Cutting Methods

- 1) *Stand Alone Key Cutting* utilizing the internal capabilities of the CodeMax®.
- 2) *Computer Assisted Key Cutting* using a computer loaded with HPC software connected to the CodeMax® via a serial cable (No. CABLE-25S) attached to the back of the CodeMax®.
- 3) *Micrometer Key Cutting* using space and depth information manually inputted into the CodeMax®.



4.1 Stand Alone Key Cutting

4.1.1 Standard Keys

The computer chip in the CodeMax® contains a database of nearly 1000 DSD Numbers. DSD stands for Depth and Space Data, these are charts of key-cutting information.

For Direct Digit keys (such as Schlage or Kwikset) or if you know the bitting needed for an indirect-coded key (such as an automotive or furniture key), you can utilize the internal DSD to cut a new key. Refer to the DSD List or to CodeSource® for the applicable DSD number, gauge point and cutter to use.

For example, if you were cutting a key for a standard Schlage large pin cylinder you would: Press DSD#. Enter “60” (press “6”, then press “0”, then press ENTER to accept this selection)

Note: At anytime during this process you can clear a wrong entry or return to the previous screen by pressing CLEAR.

The CodeMax® displays the name of the selected manufacturer and displays the correct gauging point.

For example, the Schlage display will read “Use Shoulder Stop as Gauge”.

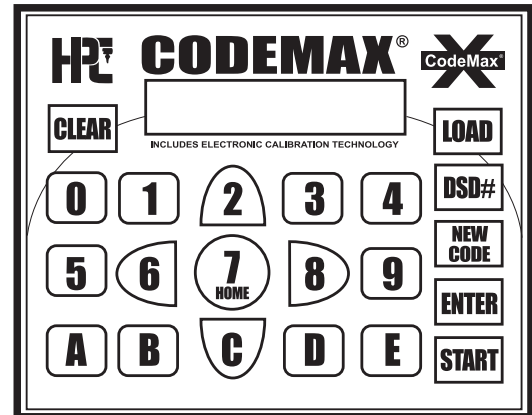
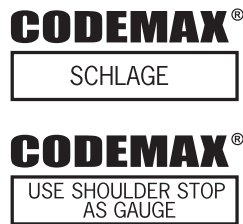

**Note: Certain manufacturers, such as Best, list bittings tip to bow. Tip to bow bittings need to be reversed to bow to tip order when inputting.*

Insert and gauge the key accordingly (refer to Section 3, Key Gauging for details).

The display then indicates “Enter Bitting”.

Enter the bitting desired starting with the cut closest to the bow.* For this example we will make thebitting “43264”. Enter “43264” by pressing “4”, “3”, “2”, “6”, “4”, and then ENTER.



The display now shows the CodeMax® is READY to cut the key.



From the Ready screen, you have several options:

1. Press START to begin cutting the key bitting shown on the screen.
2. Press NEW CODE or CLEAR and enter in a new bitting. (Remember to press Enter to accept the new bitting.)
3. Press CLEAR twice to return to the “Enter DSD Number” prompt, or twice more to reset the CodeMax®.

- Press “A” to change to the Contour Cutting Mode. Contour Cutting will remove peaks between cuts on a key, for smoother operating automotive keys (only recommended for automotive keys). Press “A” again to return to the Standard Cutting Mode.

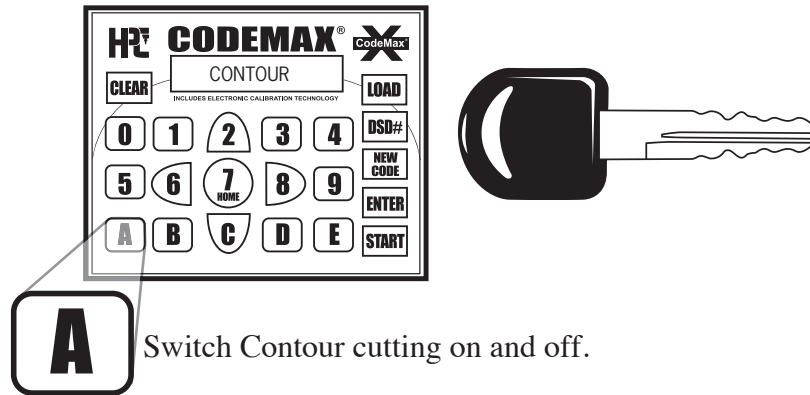

Switch Contour cutting on and off.

- Press “6” to decrease the rate of speed at which the pivot arm approaches the cutter or press “8” to increase the rate of speed at which the pivot arm approaches the cutter. This is particularly useful when dealing with hardened keys and wanting to cut them at a slower rate.

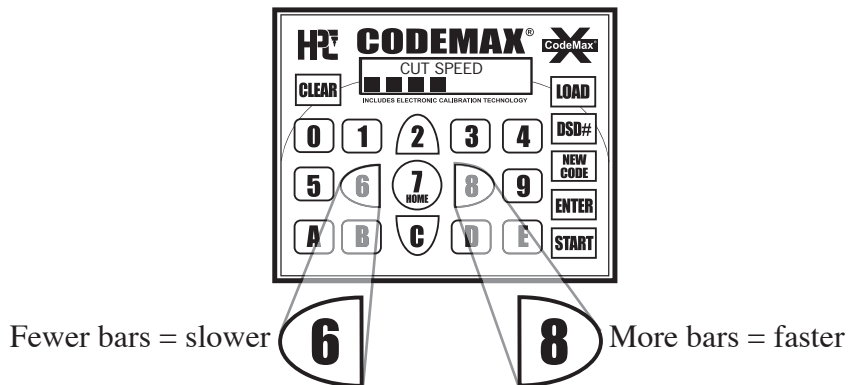

- In the case of “Double-Sided Different” keys, after cutting the first side, press ENTER to autoload the next DSD Number associated with the manufacturer chosen. If cutting a single-sided key or if the second side is the same as the first, pressing ENTER will return to the Main Screen.

4.1.2 Medeco® Keys

Some high security keys, such as Medeco and Emhart, incorporate angles in their cuts. Both the depths and angles must be determined prior to cutting the key.

Use the HPC Pocket Size Decoder (No. HKD-75) to decode the depths and angles of these high security keys, as well as standard keys.

When cutting angle-cut keys on the **CodeMax® Automatic Angler model**, the cutter head rotates automatically to make the angle cuts.

If you are using the **Standard Model CodeMax®**, then the machine pauses at each position and prompts you to manually rotate the cutter head.

1. Pull the spring loaded Angle Index Pin back.
2. Rotate the cutter head using the Pivot Pin, to the “L” on the machine to make a left angled cut, or to the “R” to make a right angled cut.
3. Release the Angle Index Pin making sure it is properly seated before proceeding to the next cut.
4. Once the Cutter Head is properly positioned, press “Enter” to begin the next cut.

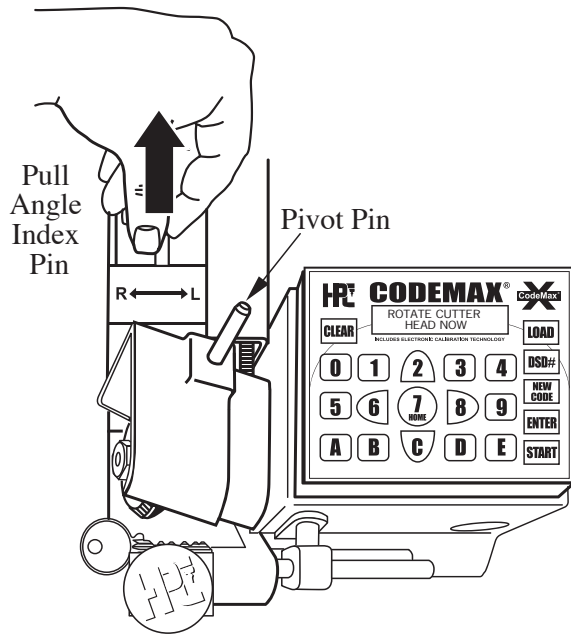

Cutting Medeco Standard Keys

Medeco Standard keys have an angle (Left, Right or Center) associated with each cut.

On the standard model CodeMax®, use DSD Number 51.

The machine will pause after each cut and prompt you to rotate the cutter head as needed.

For the **Automatic Angler model**, use **DSD Number 3051**. The bitting screen has room for 12 characters. Think of the 12 characters as 6 sets of 2 characters each, one number for the bitting and one letter for the direction of the angle, to represent each cut on the key.

For example, the bitting of **324323** with the first cut being a “**Left**” angle, the second a “**Right**” angle, the third a “**Center**”, fourth a “**Left**”, fifth a “**Right**” and sixth a “**Left**.” Using the “**B**” key for Left, the “**C**” key for Center and the “**D**” key for Right, the bitting would be entered as:**3L2R4C3L2R3L**

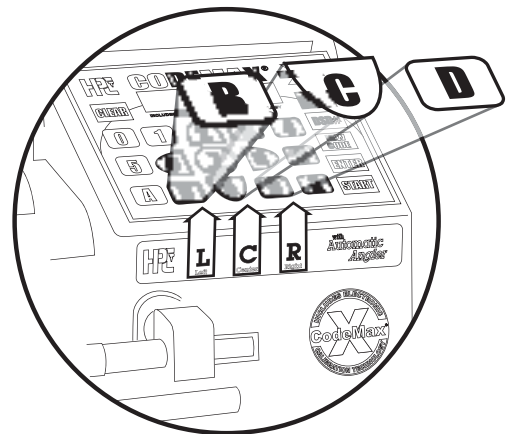

Cutting Medeco Biaxial Keys

Medeco Biaxial keys utilize the Left, Right and Center angles and add the position of the angle: “Fore” (the depth comes before the angle) or “Aft” (the depth comes after the angle). Medeco designates the angles and positions as follows:

Medeco® Code	Position & Angle
K	Fore, Left
B	Fore, Center
Q	Fore, Right
M	Aft, Left
D	Aft, Center
S	Aft, Right

On the standard model CodeMax®, use DSD Number 76.

The bitting screen will display 12 spaces to accommodate the position of the angle relative to the depth on a 6-space key. This is accomplished by inserting a zero (0) (representing the position of the angle) before the depth for an AFT cut or after the depth for a FORE cut. For example, a key that reads:

D4 3B M5 D2 3K S2
aft fore aft aft fore aft

On the standard model CodeMax® it is entered as:

043005023002

The machine will pause at each position and prompt you to rotate the cutter head as needed.

4.1.3. Use of the CodeMax® AA Automatic Angler

On the Automatic Angler model, use DSD Number 3076.

The bitting screen will display 12 spaces to accommodate both the angle and the position.

The position is designated by the sequence it is input relative to the depth.

Medeco® Code	Position & Angle	DSD 3076 Buttons
K	Fore, Left	Depth, then Left
B	Fore, Center	Depth, then Center
Q	Fore, Right	Depth, then Right
M	Aft, Left	Left, then Depth
D	Aft, Center	Center, then Depth
S	Aft, Right	Right, then Depth

Use the “B” key for Left, the “C” key for Center and the “D” key for Right.

To specify a 3-depth in the FORE position, with a LEFT angle, enter the depth then the angle: 3L.

To specify a 5-depth, in the AFT position with a RIGHT angle, enter the angle then the depth: R5.

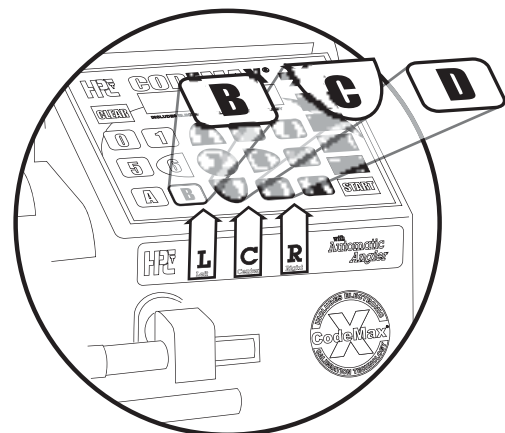

Example: 3LR2C43LR23L

3L number 3 depth in the “Fore” position with a Left angle.

R2 number 2 depth in the “Aft” position, with a Right angle.

C4 number 4 depth in the “Aft” position with a Center or no angle.

3L number 3 depth in the “Fore” position with a Left angle.

R2 number 2 depth in the “Aft” position with a Right angle.

3L number 3 depth in the “Fore” position with a Left angle.

4.1.3 After The Key Has Been Cut

After the key has been cut you will have four options:

- 1) Press START to cut an additional key to the same bitting.
- 2) Press NEW CODE or CLEAR to enter a new bitting, using the same DSD.
- 3) Press CLEAR twice to enter a different DSD number.
- 4) Press ENTER to autoload the next DSD number associated with a “Double-Sided Different” key. If no autoload specifications are present, the CodeMax® will return to the main screen.
- 5) Press CLEAR until you reach the main screen.

NOTE: At all screens you may press CLEAR to return to the previous screen.



4.1.4 Additional Notes

- 1) The CodeMax® always cuts shoulder-gauged keys from bow to tip, and tip-gauge keys from tip to bow. However, all bittings must be entered into the CodeMax® in bow to tip order.
- 2) If the original manufacturer (such as Kwikset) widens some or all of the cuts, the CodeMax® will automatically do the same.
- 3) When cutting double-sided keys where there is a shoulder on only one side of the key, or where the shoulders are not symmetrical (such as some VW keys), always cut the shoulder gauged side of the key first, then press ENTER to cut the plain side.
- 4) Because most double-sided keys are gauged by placing an uncut blade against the back of the jaw, the recommended cutting procedure is to cut the first side on the CodeMax® and then cut both sides of another blank in a duplicator, using the code-cut key as the original.
- 5) At all screens you may press CLEAR to return to the previous screen.

4.2 Computer Assisted Key Cutting

A personal computer that uses a Current Version of Windows® as its operating system, and has authorized HPCSoft™ software products properly installed, can be connected to the CodeMax® using a serial cable for computer assisted key cutting.

The CodeMax® cable (CABLE-25S) is a 25-foot serial cable designed for this purpose. It is attached to the serial port on the computer and to the RS422 port on the back of the CodeMax®. Refer to your computer manual to locate the serial port on the computer. For computers without serial ports there are USB to serial adapters available at most computer stores.

A single bitting may be downloaded from CodeSource® or KeyTrail® to the CodeMax®, or as many as 250 different bittings from MasterKing® may be downloaded for master key systems.

To download data from the computer, make sure the CodeMax® is in a clear condition. The display will read:

CODEMAX®

**Codemax Ready
HPCSoft Ver 10.0**

Follow the instructions for each software program to send data to the CodeMax®. The computer will then perform its handshake with the CodeMax® and download the data. The display will read:

CODEMAX®

**Making
Connection**

Once the download transmission is complete, the CodeMax® may display an information message about the incoming keys. This message will appear for approximately 2 seconds, then the key bitting will appear at the Ready screen.

When downloading from MasterKing®, the first bitting appears at the Ready screen and you may:

- 1) Press START to cut the key to the bitting displayed. Press START again to cut additional keys to that bitting.
- 2) Press “C” (DOWN ARROW) to move forward through the key bittings.
- 3) Press “2” (UP ARROW) to move backward through the key bittings.
- 4) Press HOME (7) to change functions. For example, this feature may be used to temporarily stop cutting keys for a master key system, so that one or more keys not in the master key system may be cut. To return to the original function press ENTER, then press HOME (7). The CodeMax® will resume from the point of interruption.

4.3 Micrometer Key Cutting

From the main screen press DSD#. The display shows:

CODEMAX[®]

Enter DSD Number

[]

Press “0” to signify that you wish to use the micrometer function of the CodeMax[®]. Press ENTER and the display changes to:

CODEMAX[®]

**Micrometer Key
Cutting Function**

The display then changes to:

CODEMAX[®]

Enter Jaw Type

[]

Press A, B, or C to signify which jaw will be used. For our example, press A. The display changes to:

CODEMAX[®]

**Choose: A for In
B for mm**

Press A or B to indicate the use of inches or millimeters for space and depth measurements. For this example, press A for inches. The CodeMax[®] advances to the main micrometer screen and the display shows:

CODEMAX[®]

**Space 0.000 In
Depth 0.000 In**

SPECIAL NOTE: To cut keys on the CodeMax® using the micrometer method you must use standard CodeMax® cutters that have a center line of .188" and 2³/₈" diameter. Keys may be gauged from either the shoulder or the tip. Tip gauged keys require special calculations. The zero point for the Horseshoe Tip Stop is 1.215 and all spacing must be calculated from this point. So, even if you are using a Tip Stop you must calculate spacings as though they were from a shoulder. The zero point for the Red Tip Stop is .940" and all spacing must be calculated from this point.

You must indicate that the first cut is to be measured from the shoulder of the key to the right. Press "8" (>). The following display appears:

CODEMAX®

Space 0.000 In>
Depth 0.000 In

The arrow to the right of the spacing display line (>) confirms that the first cut is to be to the right of the shoulder of the key. After setting the direction, set the spacing value from the shoulder to the first cut. For our example, the value is .231, so press "2", "3", "1", then press ENTER. The display changes to:

CODEMAX®

Space 0.231 In>
Depth 0.000 In

Press START and the CodeMax® aligns the Pivot Arm for the first cut. When the CodeMax® stops, press "2" (UP ARROW) to signify that the Pivot Arm will be moving up into the cutter. The display shows:

CODEMAX®

Space 0.231 In
Depth 0.000 In^

Next, indicate the depth of the first cut. Our example requires a depth of .290. Press “2”, “9”, “0”, then press ENTER. You will see the following display:

CODEMAX[®]

**Space 0.231 In
Depth 0.290^ In**

Press start to make the cut. Notice that the CodeMax[®] stays in the cut position and the cutter continues to spin. This allows you to widen the cut, if necessary, by using the space commands. Press HOME (7) to ready the machine for the next cut.

Review Of Micrometer Key Cutting Procedures

Let's quickly review the basic steps required:

- 1) Press “8” (>).
- 2) Set spacing numbers from shoulder to first cut, then press ENTER.
- 3) Press start to activate spacing stepper motor.
- 4) Press “2” (up arrow).
- 5) Enter depth numbers.
- 6) Press start for the CodeMax[®] to make the cut.
- 7) Repeat steps 1, 2, and 3 if the cut has to be widened. If the cut does not have to be widened, press Home (7) to return to the home position.

Final Micrometer Key Cutting Procedures

We will now continue with cutting an example key using the Micrometer Key Cutting Procedure.

Press “8” (>) to set the direction from the shoulder of the key.

Next, enter the cut-to-cut spacing. For our Schlage example, this is .156. Press “1”, “5”, “6”, then press ENTER and START. Notice that the carriage does not move to “.156”, but to “.387”. The CodeMax® totals the distances of our first and second cuts (.231 + .156 = .387) and the display shows the real location, 0.387.

Remember, the cutter wheel does not move laterally. Only the carriage holding the key blank moves. To position the cutter to the right of the shoulder at a designated spacing, the carriage moves to the left. Do not let this confuse you as you watch movements for spacings.

Next, indicate the direction and depth of the cut. For our example, press “2 (up arrow) to set the direction (the carriage moves up to the cutter), then press “2”, “4”, and “5” (the depth of the cut is .245). Press ENTER and START to make the cut. When the cut is complete, press HOME in preparation for the next cut.

Now that you have the hang of things, repeat steps 1 through 7 until all of the cuts are made. Once the key is complete, press CLEAR to return to the main screen.

5. Recalibration Of The CodeMax®

5.1 Electronic Calibration

The CodeMax® is capable of Electronic Calibration. Minor depth and space adjustments, as well as DSD Specific Depth adjustments, can be performed using the CodeMax® keypad and stored in the CodeMax® CPU board. These adjustments can be used to offset normal wear and tear on the machine, or after replacing or sharpening cutters.

DSD Specific adjustments allow you to make minor depth adjustments to accommodate worn locks or keys or special applications.

5.1.1 Depth Instructions

Total Machine adjustments affect all DSD's including keys downloaded from software. To make Total Machine electronic Depth Adjustments on the CodeMax[®] start with the "LOAD" button.

Press "LOAD"
Enter "CC" and press the "ENTER" button

Choose between Inches and Metric.
"A" for Inches and "B" for Metric

CODEMAX[®]

**Choose: A for in
B for mm**

Choose Depth or Space adjustment.
"A" for Depths and "B" for Space

CODEMAX[®]

**Use: A for Depth
B for Space**

If Depths were chosen the screen will read:

CODEMAX[®]

**Depth Adjustment
0.000 In**

Use the Up Arrow (2) keypad button or the Down Arrow (C) button to change the Depths. The Display will show how much of an adjustment you are making. Use the “ENTER” button when you are done.

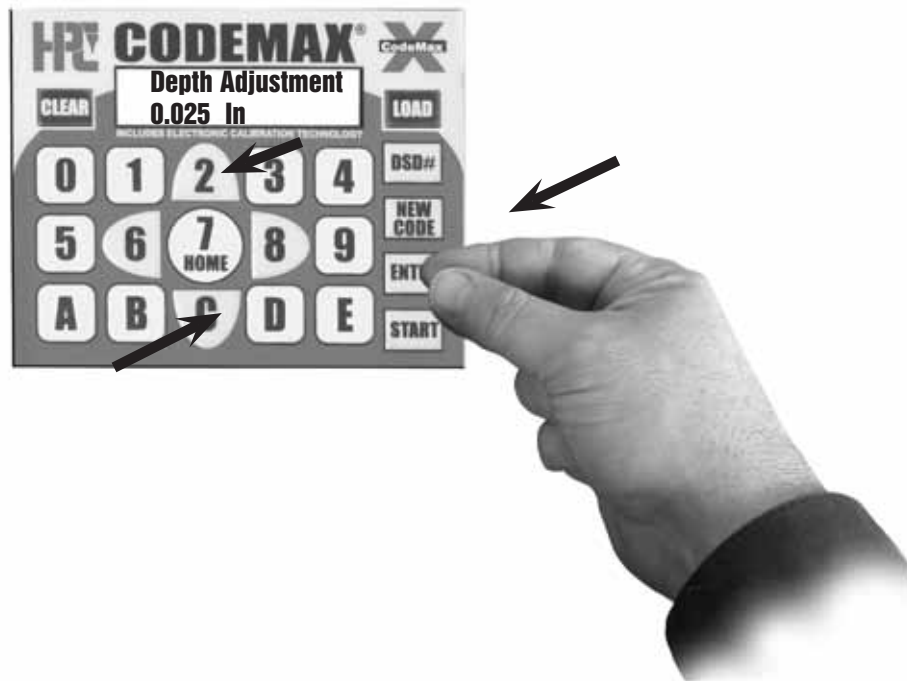

Press “A” to proceed out of the Adjustment screens or “B” to return to the Depth Adjustment screen.

CODEMAX®

Confirm 0.000 In
A=Yes B=No

Depth Adjustment Confirmation Screen will flash twice indicating the adjustment has been saved. The CodeMax® now returns to the Main menu and is ready to use.

(Although the adjustment will not be shown next time you access machine adjustments, CodeMax® saves the adjustment in memory even after power has been turned off.)

5.1.2 Space Instructions:

Total Machine adjustments affect all DSD's including keys downloaded from software. To make Total Machine electronic Space Adjustments on the CodeMax® start with the "LOAD" button.

Press "LOAD"
Enter "CC" and press the "ENTER" button

Choose between Inches and Metric.
"A" for Inches and "B" for Metric

CODEMAX®

**Choose: A for in
B for mm**

Choose Depth or Space adjustment.
"A" for Depths and "B" for Space

CODEMAX®

**Use: A for Depth
B for Space**

If Space was chosen "Space Adjustment" will flash twice and bring you to the next screen. You can choose "A" for Shoulder adjustment and "B" for Black Tip Stop adjustment.

CODEMAX®

**Use: A=Shoulder
B=Black tip**

Increase .000 ^ (no previous adjustments should be displayed)

Decrease .000 v

Use the Up Arrow (2) keypad button or the Down Arrow (C) button to change the Space. The Display will show how much of an adjustment you are making. Use the "ENTER" button when you are done.

CODEMAX[®]

Confirm +.000
A=Yes B=NO

(auto enter)

("No" returns to adjust screen)

Space Adjustment ***FLASH for 1 second***Saved +.000

Press "A" to proceed out of the Adjustment screens or "B" to return to the Space adjustment screen.

Space Adjustment Confirmation Screen will flash the adjustment and that it has been saved. The CodeMax[®] now clears and reinitializes completing the Space adjustment.

5.1.3 DSD Specific Instructions:

Use the “DSD” button and enter the DSD you want to adjust.

After displaying the DSD name and gauge point the “Biting Window” appears.

Enter a biting and hit the “ENTER” button.

Once at the “Ready Screen” press the “LOAD” button to access the DSD Specific Depth adjustment.

Note: A previously adjusted DSD will add “**ADJ**” on the top line of the display.



This DSD can be used as is or adjusted again

After hitting “LOAD” the following message will be on the screen.

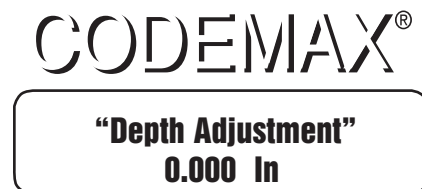

Any previous adjustments will be displayed here.

Use the Up Arrow (2) keypad button or the Down Arrow (C) button to change the Depths. The display will show how much of an adjustment you are making. Use the “ENTER” button when you are done. To clear any previous adjustments just follow the above instructions until the display reads “0.000 In”

Press “A” to proceed out of the Adjustment screens or “B” to return to the Depth adjustment screen.

CODEMAX[®]

Confirm 0.000 In
A=Yes B=No

Depth Adjustment Confirmation Screen will flash twice indicating the adjustment has been saved.

You will now return to the “Ready...**ADJ**” screen and cut your key with the new adjustment. As long as the adjustment is stored all keys cut with this DSD will be offset by the selected amount.



5.2 Manual Calibration

The Electronic Adjustment Function is suitable for making minor adjustments. Manual Calibration will be required if the carriage is replaced or is accidentally moved significantly out of position.

I. Space Calibration

No readjustment of space is required when changing from one depth and spacing specification to another. The information sent by the DSD number or computer positions the correct lateral alignment when using factory cutters. The need to readjust the space is rare and should be attempted only after the more common causes for miscut keys have been eliminated.

Remember, when originating a key by code, quite often, code numbers are misread. Locks can sometimes be coded incorrectly when they are new, and code books occasionally have typographical errors. All this distracts from successful cutting of keys by code.

You may proceed after eliminating the above mentioned causes for miscut keys and checking for correct depth calibration.

5.2.1 Cutting Too Close To The Tip (On Keys Gauged From The Tip Stop)

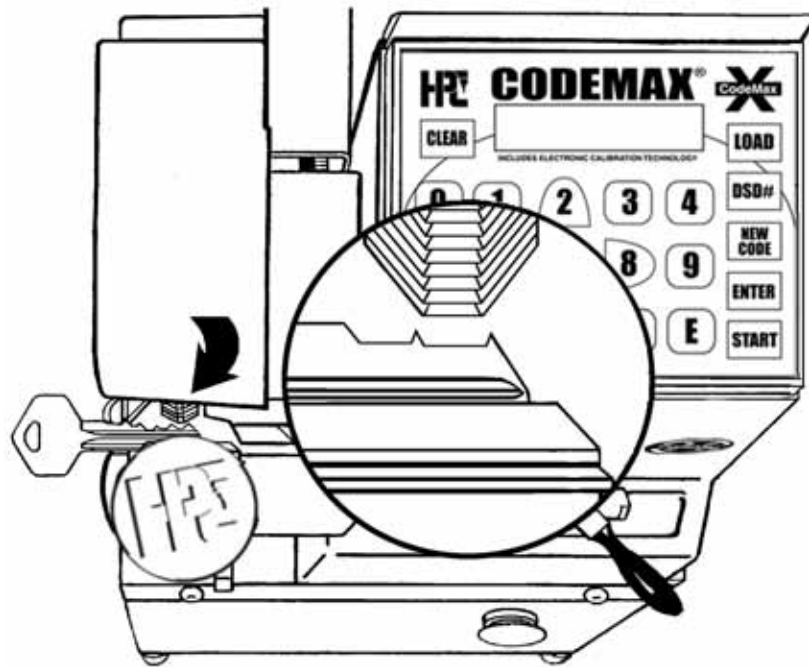

Fig. 1

Tools required: 5/64" Allen wrench, factory cut key, rubber or rawhide mallet.

- 1) Select a tip-gauged, factory cut large cylinder type key, such as Best, Falcon, or Ford. Make sure that all cuts are deeper than a #1 depth.
- 2) Install the correct cutter wheel.
- 3) Turn on the CodeMax®.
- 4) Select and enter the proper Depth and Spacing Data number.
- 5) Enter in all #1 cuts for the depths. Then press ENTER to accept, and then press START to begin the cutting process.
- 6) The CodeMax® will start to travel laterally towards the key. When the machine travels to the first cut (closest to the tip) and the key begins traveling towards the cutter (making depth cut), push the emergency stop button.
- 7) Check to see if the cutter is in the center of the cut (see Fig. 1).
- 8) If the cutter is too close to the tip of the original key, use a 5/64 inch allen wrench to loosen the four set screws on the lower inside and bottom of the pivot arm (CM-1024X).

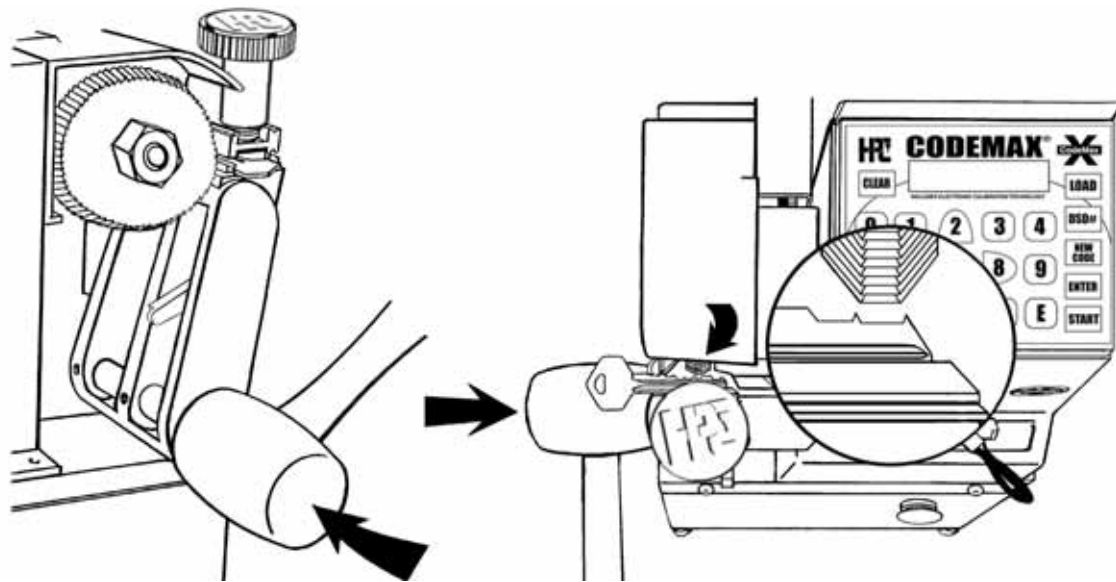

Fig. 2

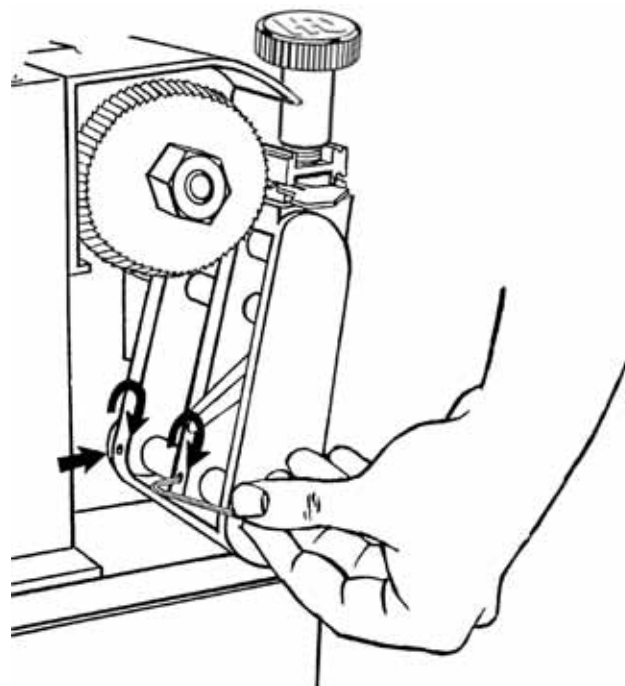

Fig. 3

- 9) With a small rawhide or plastic mallet, lightly tap the lower, left side of the Pivot Arm until the pin seat of the cut is directly opposite the flat of the cutter (see Fig. 2). With the cutter aligned opposite the cut, retighten the set screws (see Fig. 3).
- 10) Release the Emergency Stop Button. The Pivot Arm will return to the HOME position.

Note: You may have to recalibrate the Shoulder Gauge after recalibrating the Tip Gauge.

5.2.2 Cutting Too Far From The Tip (On Keys Gauged From The Tip Stop)

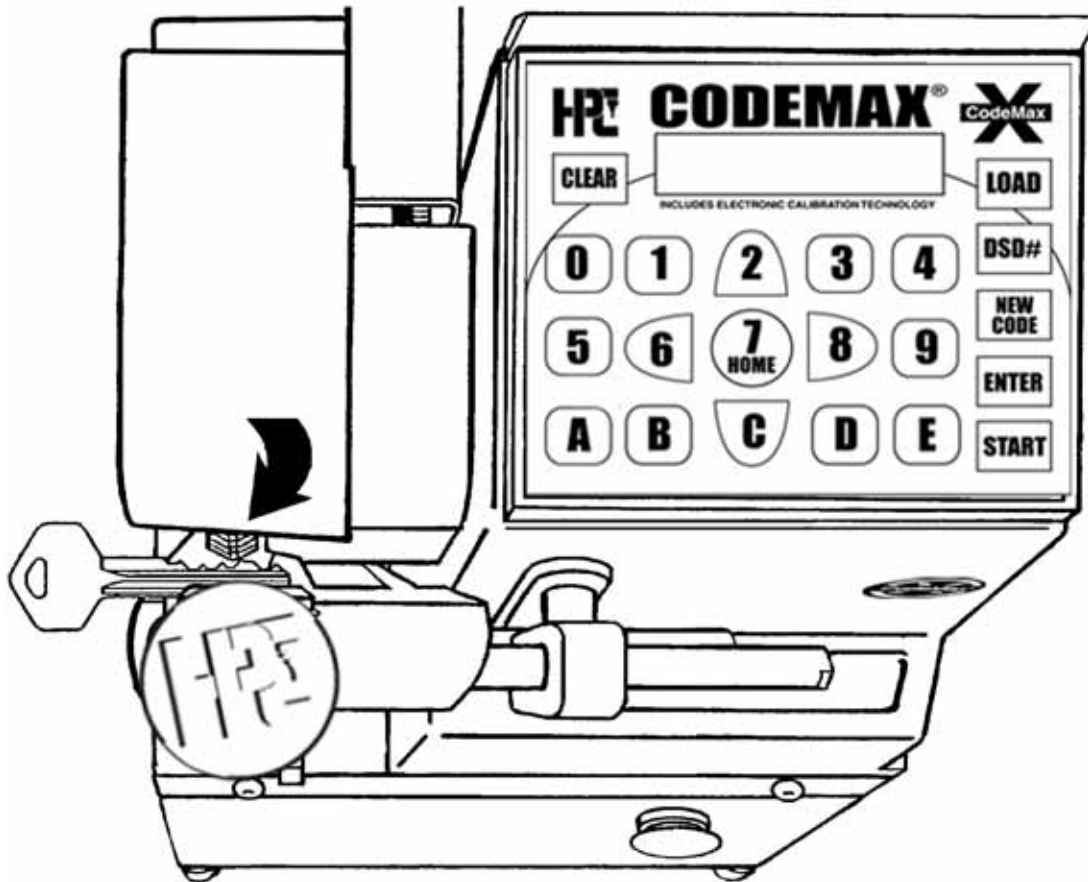

Fig. 1

- 1) Select a tip-gauged, factory cut large cylinder type key, such as Best, Falcon, or Ford. Make sure that all cuts are deeper than a #1 depth.
- 2) Install the correct cutter wheel.
- 3) Turn on the CodeMax®.
- 4) Select and enter the proper DSD number.
- 5) Enter all #1 cuts for the depths. Then press ENTER to accept, and then START to begin the cutting process.
- 6) The CodeMax® will start to travel laterally towards the key. When the machine travels to the first cut (closest to the tip) and the key begins traveling towards the cutter (making the depth cut), push the Emergency Stop Button.
- 7) Check to see if the cutter is in the center of the cut (see Fig. 1).

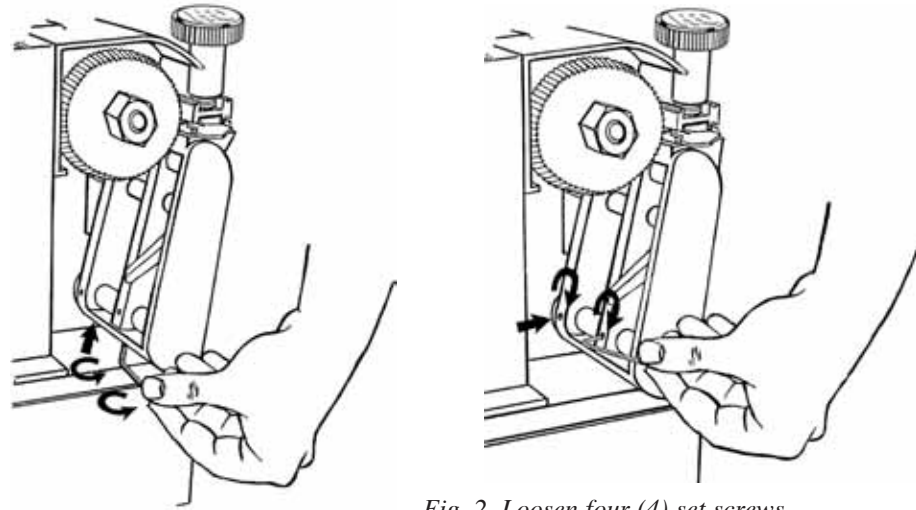

Fig. 2. Loosen four (4) set screws

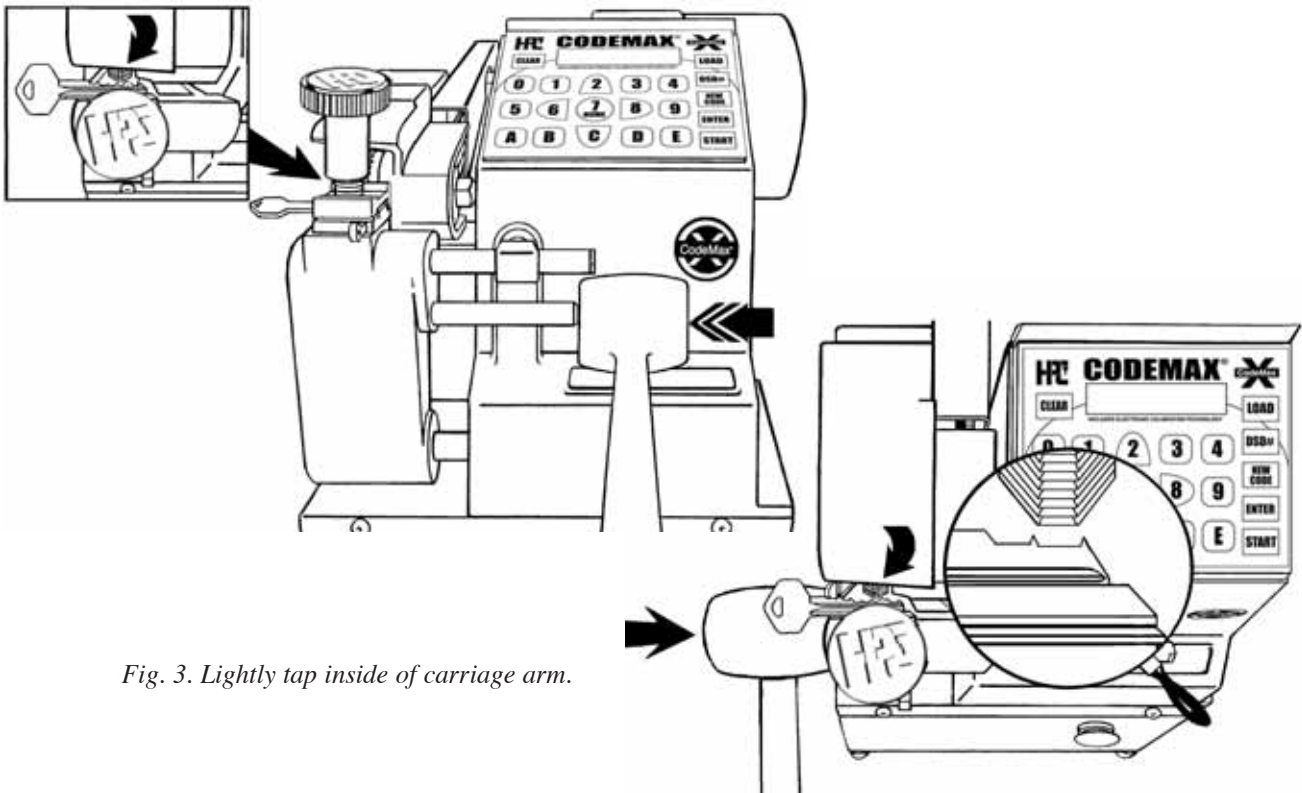
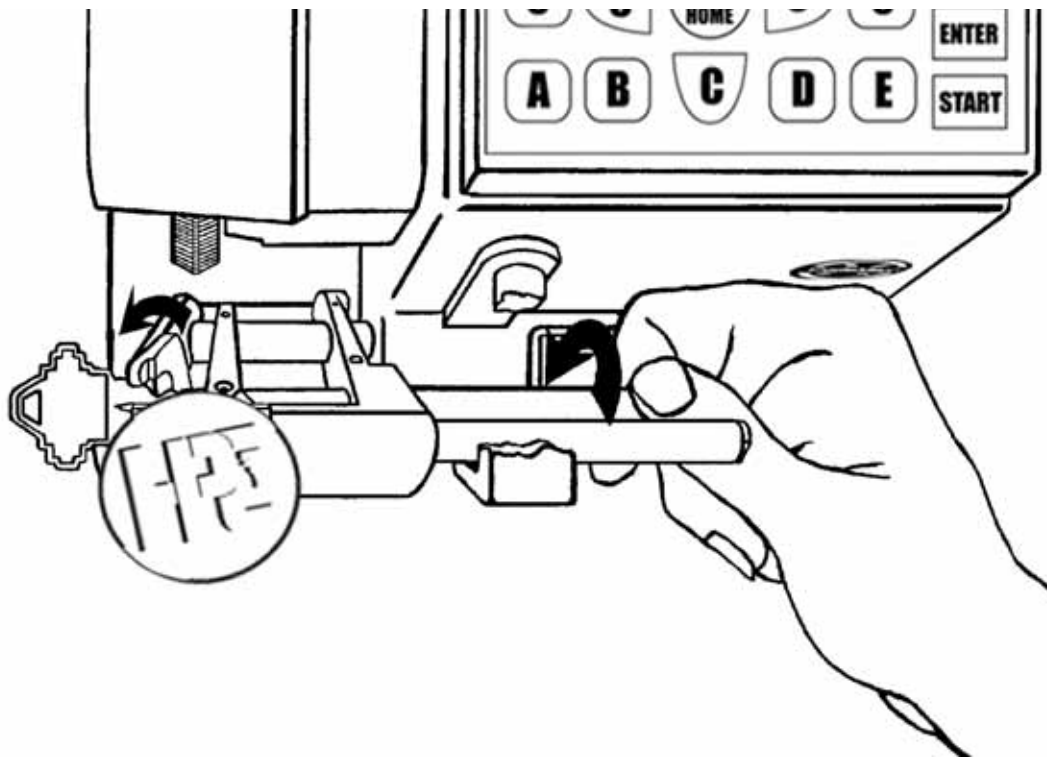

Fig. 3. Lightly tap inside of carriage arm.

- 8) If the cutter is too far from the tip of the original key, use a 5/64 inch allen wrench to loosen the four set screws on the lower inside and bottom of the Pivot Arm (CM-1024X) (see Fig. 2).
- 9) With a small rawhide or plastic mallet, lightly tap the inside of the Pivot Arm to move the cutter closer to the top of the key while centering the cutter flat with the pin seat (see Fig. 3).
- 10) Release the Emergency Stop Button. The Pivot Arm will return to the Home position.

Note: You may have to recalibrate the Shoulder Gauge after recalibrating the Tip Gauge.

5.2.3 Cutting Too Far From The Shoulder



Note: Only recalibrate the shoulder gauge after being sure that the tip gauge is properly calibrated.

- 1) Select a shoulder gauged, factory cut type key, such as a Schlage or Arrow. Check to see that the #1 space (closest to the shoulder) is greater in depth than a #1 cut.
- 2) Install the correct cutter wheel.
- 3) Turn the CodeMax[®] on.
- 4) Select and enter the proper DSD number.
- 5) Enter in a #1 cut for the depth. Then press ENTER to accept, and press START to begin the cutting process.
- 6) The Pivot Arm will start to travel laterally towards the key. When the Pivot Arm travels to the first cut (closest to the shoulder) and the key begins traveling towards the cutter (making the depth cut), push the Emergency Stop Button.
- 7) Loosen the key in the jaw. Slide the key to your right until the pin seat of the cut is directly opposite the flat of the cutter. Tighten the key in the jaw.
- 8) Release the Emergency Stop Button to allow the machine to return to the Home position.

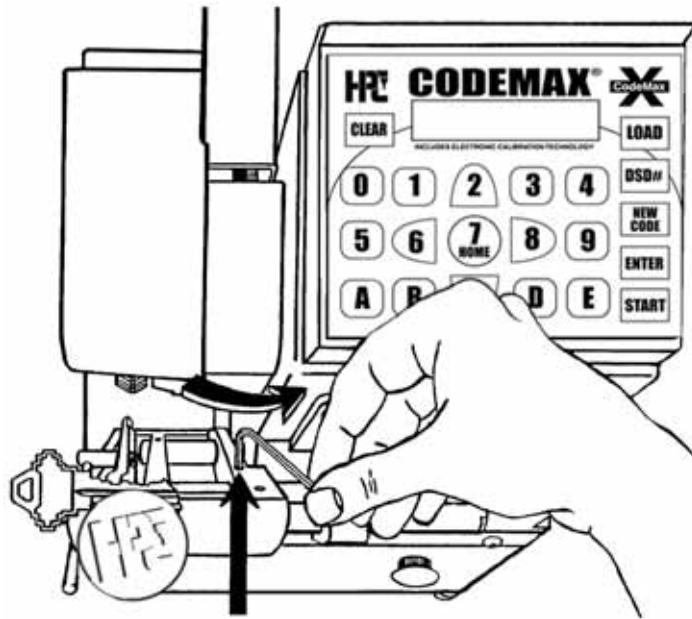

Fig. 1

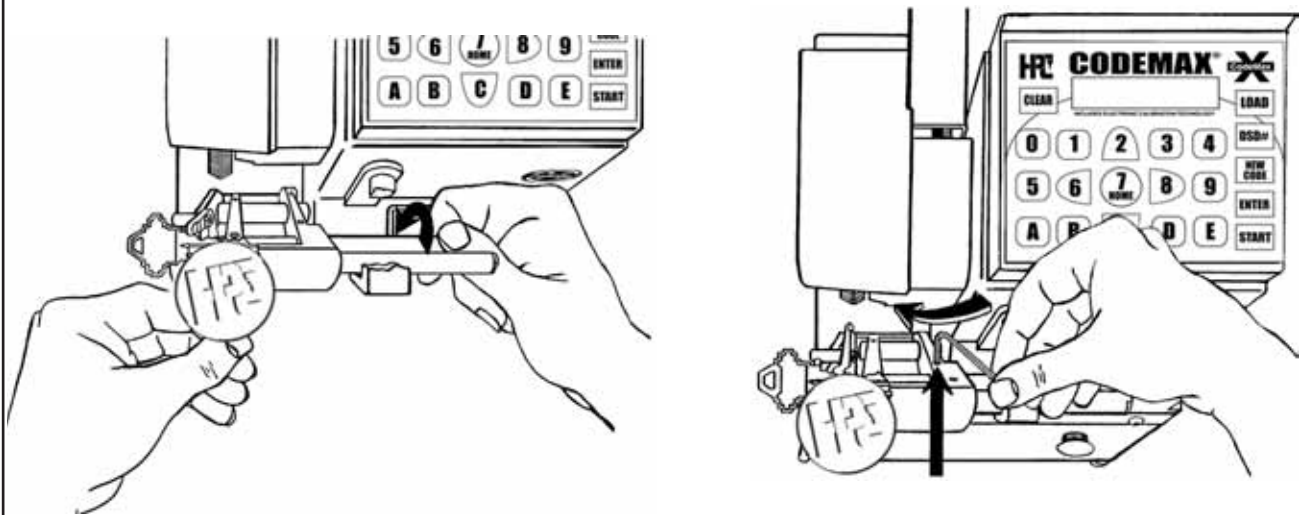

Fig. 2

- 9) Loosen the set screw that holds the Turn Bar in place in the Pivot Arm. See Fig. 2. Swinging the Shoulder Gauge should also rotate the Turn Bar.

Note: If the Turn Bar does not rotate, squirt some WD-40, or equivalent, on the threaded end. Then work it loose by simultaneously swinging the Shoulder Gauge and rotating the Turn Bar (see Fig. 1).

- 10) Swing the key Shoulder Gauge down to release the Turn Bar. Then, firmly gripping the right end of the Turn Bar so that it remains stationary, swing the key Shoulder Gauge up against the key. The Shoulder Gauge should be just touching the shoulder of the key. Now, without rotating the Turn Bar anymore, tighten the set screw that holds the Turn Bar (see Fig. 2).

5.2.4

Cutting Too Close To The Shoulder

Note: Only recalibrate the Shoulder Gauge after being sure that the Tip Gauge is properly calibrated.

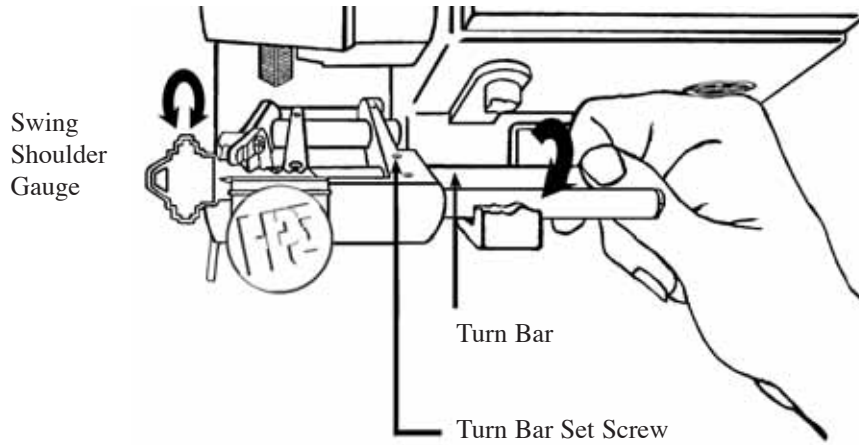

Fig. 1

- 1) Select a shoulder gauged, factory cut original large cylinder type key, such as a Schlage or Arrow. Check to see that the #1 space (closest to the shoulder) is greater in depth than a #1 cut.
- 2) Install the correct cutter wheel.
- 3) Turn the CodeMax® on.
- 4) Select and enter the proper DSD number.
- 5) Enter in a #1 cut for the depth. Then press ENTER to accept, and then press START to begin the cutting process.
- 6) The Pivot Arm will start to travel laterally towards the key. When the Pivot Arm travels to the first cut (closest to the shoulder) and the key begins traveling towards the cutter (making the depth cut), push the Emergency Stop Button.
- 7) Loosen the key in the vise. Slide the key to the left to line up the cutter flat opposite the pin seat. Tighten the key in the jaw.
- 8) Release the Emergency Stop Button to allow the machine to return to the Home position.
- 9) Loosen the set screw that holds the Turn Bar in place in the Pivot Arm. Swinging the Shoulder Gauge should also rotate the Turn Bar.

Note: If the Turn Bar does not rotate, squirt some WD-40, or equivalent, on the threaded end. Then work it loose by simultaneously swinging the Shoulder Gauge and rotating the Turn Bar. (See Fig. 2)

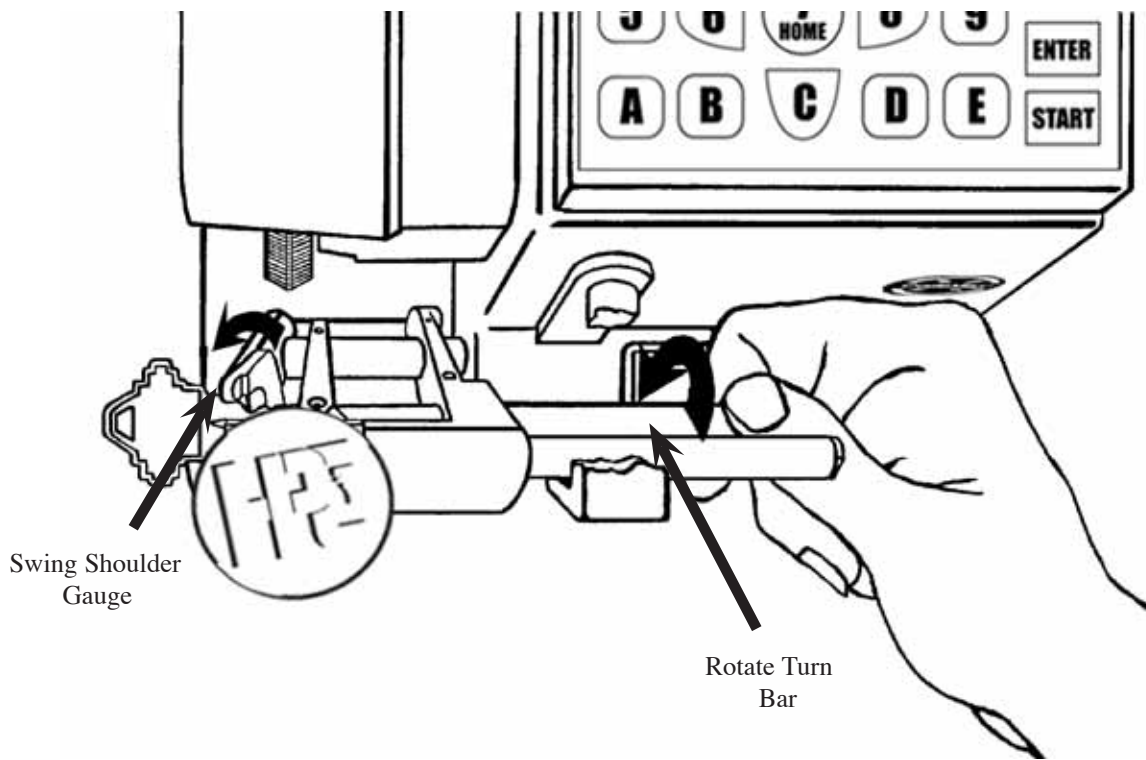

Fig. 2

- 10) Swing the key Shoulder Gauge down to release the Turn Bar. Then, firmly gripping the right end of the Turn Bar so that it remains stationary, swing the key Shoulder Gauge up against the key. Rotate the Turn Bar to the desired position and hold it there. The Shoulder Gauge should just touch the shoulder of the key (see Fig. 2). Now, without rotating the Turn Bar any more, tighten the set screw that holds the Turn Bar.

5.3 Depth Adjustment

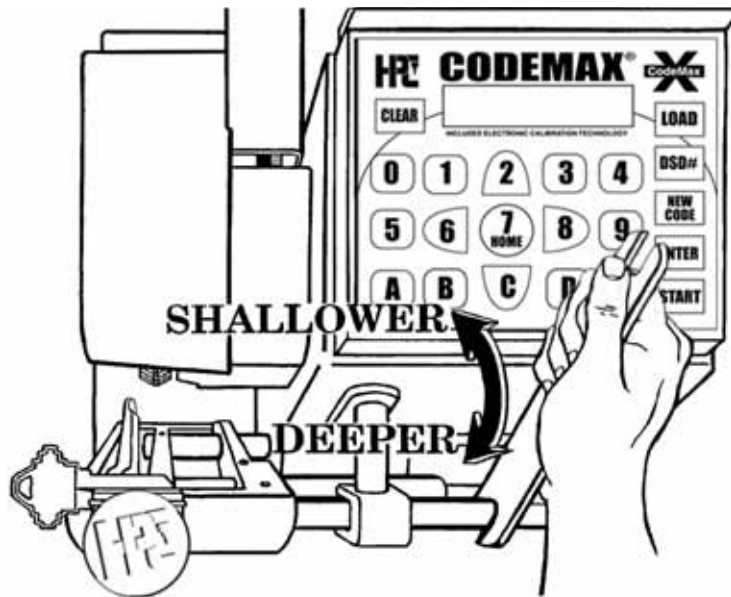

Fig. 1

The need to readjust depth is caused by cutter wear or cutter replacement. It is easily accomplished by rotating the eccentric shaft (CM-1041) with the 3/8 inch end of WRENCH-1, turning towards you to cut deeper, and away from you to cut shallower. The 180 degree rotation allows depth adjustments of plus or minus .015 inch. Since the eccentric shaft is made of drill rod, there is no need to loosen the two binding screws prior to rotating it (see Fig. 1).

Tools Required: Key Micrometer or Caliper, Key Blanks, Correct Depth and Spacing Data, WRENCH-1 (use 3/8 inch end for depth adjustment).

- 1) Install a key blank in the CodeMax[®] jaw.
- 2) Turn the CodeMax[®] on.
- 3) Select and enter the proper DSD number (e.g. 60 for Schlage Large Pin).
- 4) Enter the depths, press ENTER to accept, and press START to begin the key cutting operation.
- 5) After the key has been cut, use a micrometer or caliper to measure the depth cut and compare it against the Depth and Spacing specifications chosen in step 3 above. If the reading of the micrometer is the same as the Depth and Spacing specifications, the machine is cutting correctly. If the cuts are higher or lower, adjust the Eccentric Shaft as explained in the beginning of this section (see Fig. 1). When checking the calibration on a key machine, it is very important to use the proper tools in order to maintain the accuracy of the machine. A key micrometer or caliper is a small investment and is highly recommended to acquire the greatest accuracy.

6. Updates

Updates to the CodeMax[®] are now performed using your PC and a CD supplied by HPC, Inc. Connect the Serial Cable (included with CodeMax[®]) to the correct Com Port on your PC and the RS422 port on the back of the CodeMax[®]. Follow the directions that come with the CD to update your CodeMax[®]. It is no longer necessary to open any part of the CodeMax[®] to perform updates.



Program name: Update.exe

To start, double click the desktop shortcut **CodeMax[®] Update**, or click **Start, Program files, HPCSoft[™] and CodeMax[®] Update** or, in My Computer, open your C: drive, open the Program Files folder, open the HPCSoft[™] folder, open the CodeMax[®] Update folder, double click **Update.exe** (application).

Make sure your serial cable is connected to the back of the CodeMax[®].

To update your CodeMax[®], click on the Com Port to which CodeMax[®] is connected and click **Start Update**.

Status will display progress: Waiting for Load Command, Waiting for STX, Sending Data (514 bytes, 1, 2, etc.), Waiting for ACK, Send Complete. During the update process, CodeMax[®] screen will display "Starting Upgrade **Please Wait**". CodeMax[®] will beep when the update is completed.

If the new update information does not appear in CodeMax[®], repeat the update process. Be sure you are using the latest files.

If CodeMax[®] does not beep on completion of the update process, or if the update process is interrupted, or if the CodeMax[®] screen remains dark after Send Complete, use the following correction procedure:

1. Turn off your CodeMax[®], leave off until instructed below.
2. On your computer, open **My Computer**
3. Open the **C: drive**.
4. Open the Program Files folder.
5. Open the HPCSoft folder.
6. Open the CodeMax[®] Update folder
7. LEAVE THE CodeMax[®] TURNED OFF!
8. In HPC CodeMax[®] Update Program, click **Program**.
9. Click **Start Update**
10. When Status reads "Waiting for STX", ON CodeMax[®].
11. CodeMax[®] operating instructions will download.



If your CodeMax[®] fails to start after this procedure, contact HPC Key Machine Services.

7. Troubleshooting

Problem: The CodeMax® is turned on but nothing appears on the display screen and the internal stepper motors do not start.

Solution: Check the cord, fuse, and the available power supply.

Problem: The CodeMax® is turned on but all that appears on the display screen are square blocks.

Solution: Remove the Key Pad from the casting. This problem is most often associated with a shorted keyboard wire against the casting. Once the keyboard has been removed from the casting, attempt to turn on the machine again. If the screen starts normally, inspect the keyboard wire or call HPC to obtain a new keyboard wire.

Problem: The stepper motors jam while using the CodeMax®.

Solution: Try turning off the CodeMax® for a few seconds to clear the memory, then turn it back on to reset the machine. If this does not clear the jam, consult factory assistance.

Problem: Keys are not being cut accurately.

Solution: Check three possibilities: Either your cutter wheel is dull (or not the proper diameter), the machine is out of adjustment, or the cutter belt is loose. Attempt to cut the key utilizing the micrometer function. If the keys cut utilizing the micrometer function are also not accurate, the machine probably requires adjusting. Make sure the belt is snug (not overtight) and see Section 5: Recalibration of CodeMax®.

Problem: The CodeMax® is turned on but the stepper motors produce a grinding sound, like they have crashed into the casting.

Solution: Turn off the machine (several electronic switches may have gone bad). Under these conditions you should consult factory assistance.

In the event that this troubleshooting section does not solve your problems, or you have any additional questions, call the HPC Service Center:

800.323.3295

847.671.6280

Monday-Friday

8:00am-3:30pm Central Time



CodeMax®



8. Glossary

Autoload:

The downloading of information from compatible software packages.

CodeMax®:

HPC's computerized code machine.

Contour Cutting:

The carriage moves laterally across the cutter, producing a key with no peaks between cuts.

Depth:

Measured in thousandths of an inch or hundredths of a millimeter. Refers to y-axis cutting on the CodeMax®. Also, a measurement from the bottom of the key to the root of the cut.

Emergency Stop Button:

A red button in the front of the CodeMax® used for stopping all machine movements.

Jaw:

The vise that holds the key in position for cutting on the CodeMax® or any other machine.

Jaw Type:

Denoted by the letters A, B, or C. Indicates the proper jaw used for cutting a specific key.

Plain Side:

The flat side of the key which faces towards the cutter when properly positioned for cutting (the gauging point for this type of key is referred to as a Left Side Jaw Gauge).

Series:

A set of numbers within a given range, which refers to a key code number.

Shoulder Gauge:

Used to gauge standard cylinder and automotive keys. (Refer to section 3.3).

Shoulder Side:

The non-flat side of the key which faces towards the cutter when properly positioned for cutting (the gauging point for this type of key is referred to as a Shoulder Gauge).

Speed Adjustment:

Increase or decrease rate of feed in the y-axis or depths.

Tip:

The end of the key that enters the lock first. Also, certain keys may be gauged utilizing the tip of the key (the gauging point for this type of key is referred to as Red Tip Stop or Horseshoe Tip Stop gauging).

Tip Gauge:

Used to gauge keys with no shoulders. (Refer to section 3.3)

Widen Cut:

On keys such as Kwikset, Weiser, Volkswagen, etc. the x-axis (or spacing) often needs to be widened more than the standard cutter wheel allows. In this manual, this is usually referred to as general widening or specific widening. This is a function that is specified by the manufacturer and performed automatically by the CodeMax®.

9. Exploded Views

Pivot Arm With Safety Switch Assembly

#	Description	Stock #
1.	Easy Grip Wing Nut	EGN-1
2.	Ball Bearing Washer	BBW-2
3.	Top Jaw	CM-1056MA
4.	Spring	CM-1293MA
5.	Stud	CM-1019MA
6.	Ball Bearing	CM-50108
7.	Set Screw	CM-50110
8.	Bottom Jaw (factory installation recommended)	CM-1055MA
9.	Tip Stop	CM-1054MA
10.	Spring	CM-1090MA
11.	Set Screw	CM-50139
12.	Eccentric Shaft	CM-1041
13.	Set Screw	CM-50109
14.	Set Screw	CM-50112
15. & 16	Turn Bar & Shoulder Gauge	CMB-FG
17.	Retaining Ring	CM-50105
18.	2-56 Screw	MAX-92
19.	Shoulder Gauge Wire Assembly	MAX-90
20.	Shoulder Gauge Micro Switch Bracket	MAX-91
21.	6-32 Set Screw	MAX-89

CodeMax® Pivot Arm with Safety Switch Assembly

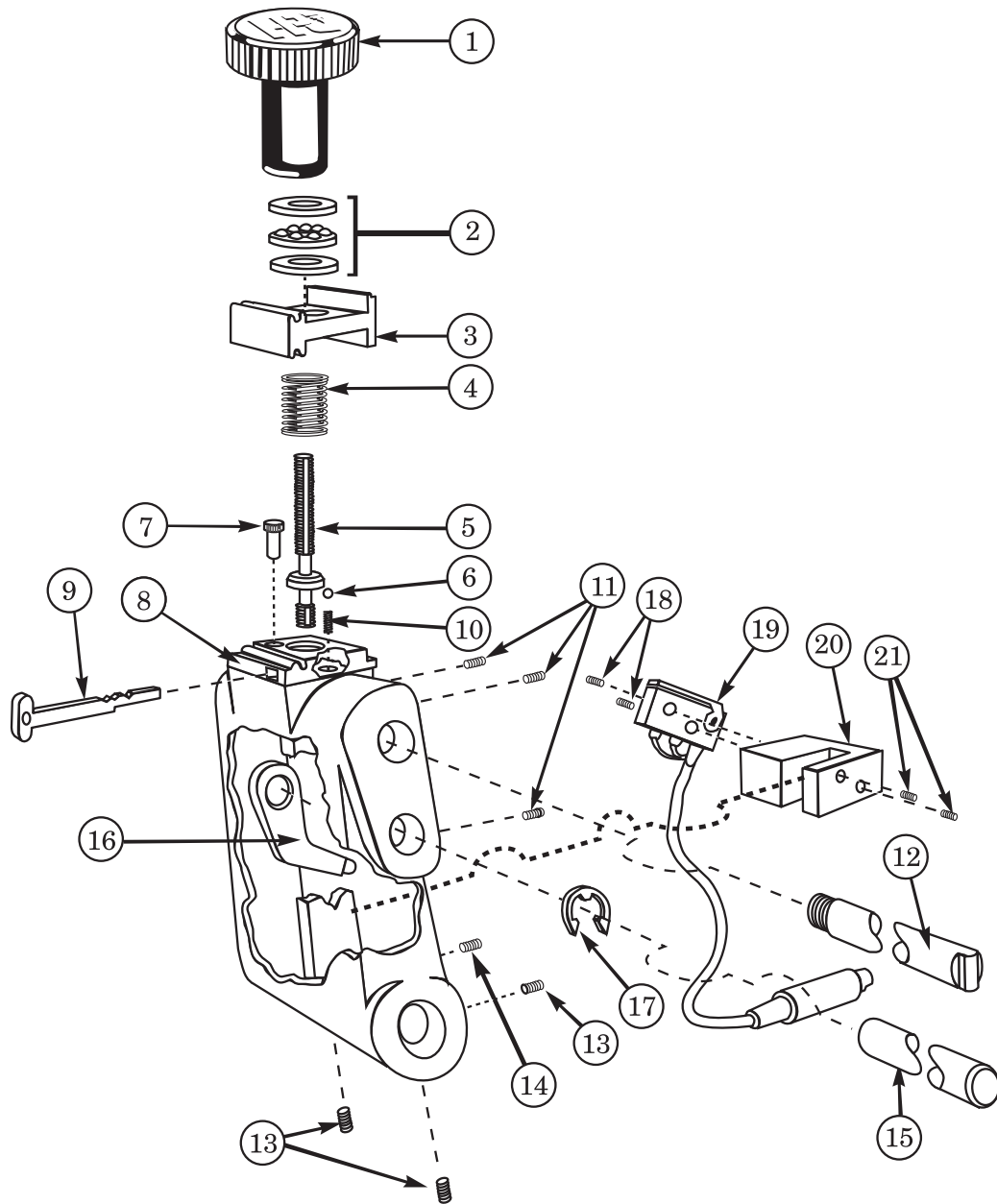

CodeMax®



CodeMax® Parts List

#	Description	Stock #
1.	Keypad	MAX-4
2.	Pad Locator	MAX-5
3.	Keypad Display Circuit Board	MAX-6
4.	Pivot Arm Assembly	CM-1024X
5.	Cutter Head Assembly	CM-1053X
6.	Grip Spring	CM-1079
7.	Belt Guard	CM-1014B
8.	Angle Index Pin	CM-1042
9.	Belt	CM-1083MA
10.	Motor Pulley	CM-1060MA
11.	Set Screw	9100-11
12.	Nut	CM-50148
13.	Screw	CM-50158
14.	Motor Mounting Bracket	CM-1040MA
15.	Hex Nut	CM-50157
16.	Screw	CM-50167
17.	Motor	CM-1080MA
18.	Pivot Pin	CM-1043
19.	Washer	CM-50100
20.	Power Cord	MAX-34
21.	Screw	MAX-35
22.	Plunger U-Bracket	MAX-43
23.	Display Board Wire Assembly	MAX-44
24.	Screw #8-32 x 1/4	MAX-46
25.	Gasket	MAX-47
26.	Rubber Bumper	CM-50133MA
27.	Screw	CM-50134
28.	Amp Fuse	MAX-78
29.	Washer	CM-50167-1
30.	Motor Support	CM-50186
31.	Motor Support Screws (2)	CM-50188

Circuit Connections

A1	connects to:	A
B1	connects to:	B
C1	connects to:	C
D1	connects to:	D
E1	connects to:	E
F1	connects to:	F
G1	connects to:	G
H1	connects to:	H
J1	connects to:	J

CodeMax® Primary Assembly and Circuit Connections

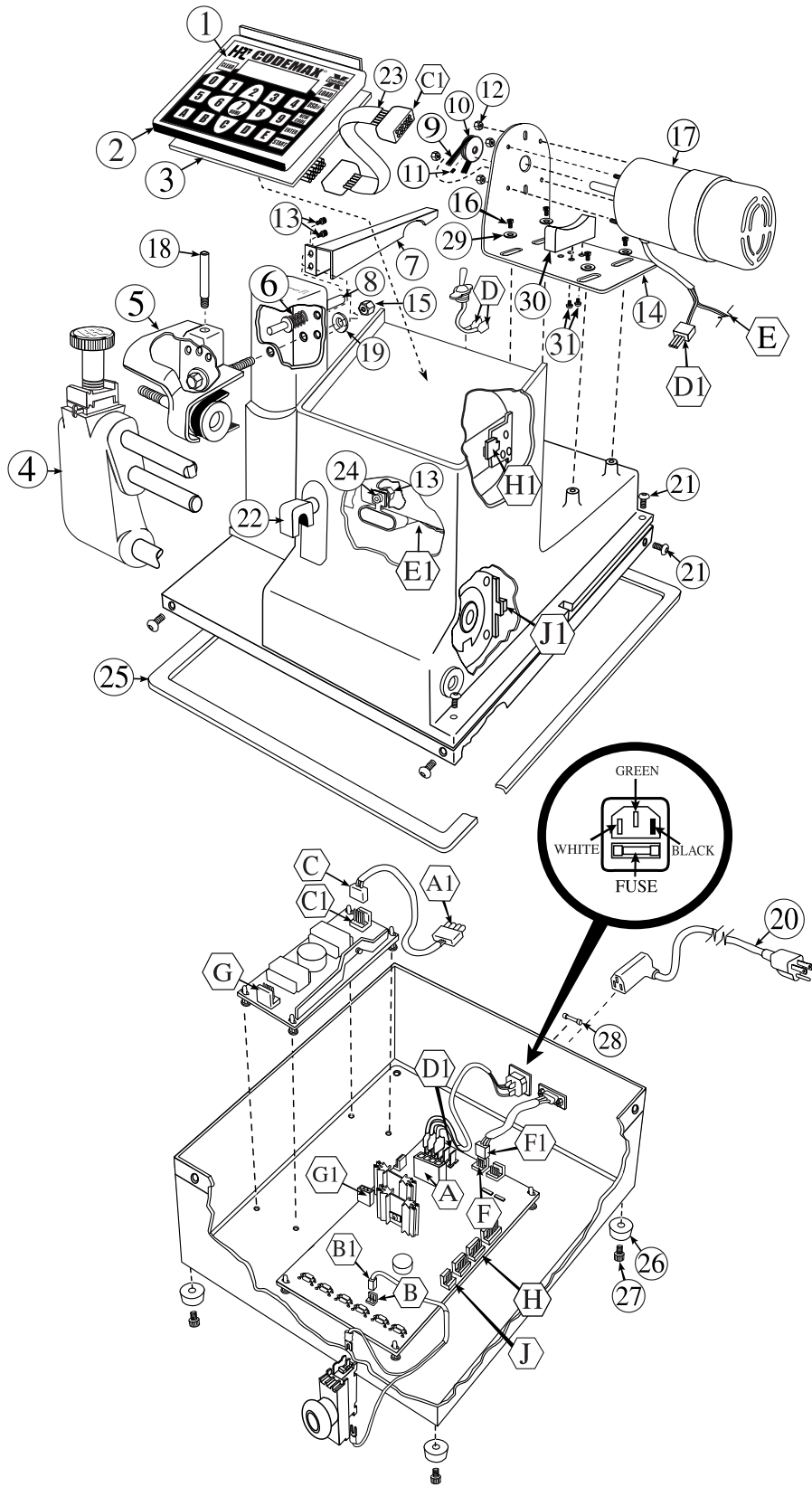

CodeMax®



10. Preventive Maintenance, Lubrication, Repairs, and Warranty

- 1) **WARRANTY** — The CodeMax® Code Machine is fully warranted for one year from the date of purchase, against factory defects in material and workmanship. Mail the Warranty Card and a copy of your invoice immediately, to validate your warranty. Should your machine require factory repairs, please contact the Key Machine Service Department before returning your machine.

During the one year warranty period, you will be billed for handling and shipping only.

- 2) **MOTOR** — The motor is equipped with sealed bearings that require no lubrication.
- 3) **CUTTER HEAD** — The cutter head is equipped with precision ball bearings for years of trouble free service and requires no lubrication. The cutter head swivel surface and plunger angle holes should be given a light coat of LPS#3 or equivalent, once every four to six months.
- 4) **BEARINGS AND SLIDING SURFACES** — These are to be given a light coat of a light grease at least every six months.
- 5) **EXPOSED STEEL SURFACES** — All remaining exposed steel shafts, cutters, etc., should be sprayed with WD-40 or equivalent light oil at least every six months. Wipe off any excess.
- 6) **CLEANING** — Remove all brass chips, dirt, and grit from the surface of your machine daily, with a soft bristle brush. Take particular care in keeping the jaw area clean and free of all residue build-up.
- 7) **CALIBRATING DEPTH FOR RESHARPENED CUTTERS** — Sharpening cutters changes the diameter; HPC, Inc. recommends replacing cutters instead of sharpening. The diameter of a resharpened cutter is smaller and therefore will make cuts shallower (if no depth adjustment is made). In order to maintain matched cutter diameters, all cutters for this machine must be resharpened at the same time, and all diameters must be sharpened proportionately.
- 8) **DRIVE BELT** — The drive belt (CM-1083MA) was selected especially for this machine and should give years of good service. If it becomes worn or broken and requires replacement, be sure to install the new belt with the teeth outward.

Note: The drive belt is somewhat more noisy when it is made to “cross-over” as the cutter head is swiveled to either the left or right angle when cutting Medeco® keys.

HPC Key Machine Service Dept.
Tel: 800.323.3295 (USA & Canada)
Tel: 847.671.6280
Monday-Friday
8:00 - 3:30 Central Time

HPC SERVICE CENTER

If your HPC Key Machine should require service, please note the following information:

HOURS: The HPC Service Center answers questions involving key machine repair and replacement parts Monday through Friday from **8:00 am to 3:30 pm Central time**.

Please call **800-323-3295** (from the U.S. and Canada) or **847-671-6280** (from other countries).

REPAIRS: We recommend the replacement of cutters, brushes and external parts, the preventive maintenance and recalibration (as outlined in this manual) be the only repairs or adjustments that are done by the user. Internal parts and mechanisms should be factory-repaired only. Additional repair charges may be incurred by attempting to make these types of repairs by yourself.

FACTORY SERVICE: If you need to send your HPC key machine in for repair, first call the HPC Service Center to obtain a Repair Order number, then follow these instructions:

Include a letter explaining the problem you are having, as well as any other work you want done on the machine. Make sure your business name, address and phone number, as well as the name of the contact person are on the letter.

Your machine should be equipped with an HPC cutter when it is sent in for repairs. If you are sending in a Blitz™ or CodeMax™ machine also include the Black Horseshoe Tip Stop to insure proper tip gauge calibration. Please do not send in any other accessories (such as other cutters and code cards).

Pack the machine securely in a box strong enough to prevent damage during shipping (preferably the original box).

The Repair Order Number should be marked on the outside of the box.

All machines must be shipped prepaid. Collect shipments will not be accepted.

Our shipping address is:

HPC, Inc.
Attn. Service Center
3999 N. 25th Avenue
Schiller Park, IL 60176 USA

REPAIR CHARGES & ESTIMATES: Upon receipt and evaluation of your machine our technicians will provide a written estimate (by fax) of the repair charges. Some problems may be detected only while the repair work is being done. If after informing you of the repair estimate it becomes apparent that the cost will be higher, you will be notified of the additional charges before any additional work is done.

REPLACEMENT PARTS: Key machine parts can be purchased through an Authorized HPC Distributor or directly from the HPC Service Center. When ordering parts over the phone, please have the part numbers and descriptions ready to expedite the ordering process. A parts listing and an exploded view drawing is included in this manual. If the parts are needed urgently, express processing is available at an additional charge.

PAYMENT: Payment for parts and repair is required at the time of repair and before the parts are shipped. We accept payment by credit card (Visa, Mastercard or Discover) or by check. Repaired machines and parts can also be sent C.O.D. with an extra charge. If you wish to have your Authorized HPC Distributor billed for the parts or repairs, the distributor must call us with approval of the billing and provide a purchase order number for the parts or work being done, before the machine is repaired or parts are shipped.

Unless otherwise specified, key machines that are not under warranty will be shipped C.O.D. with an extra charge after the repairs have been made.

LOANER MACHINES: Sorry, but we do not have loaner machines available.



CodeMax®

