

**Signature® Series  
Information and  
Field Service Guide**

**SARGENT®**  
**ASSA ABLOY**



**A7438F  
9/16**

Copyright 2014, 2016, © SARGENT Manufacturing. All rights reserved.  
Reproduction in whole or in part without the express written  
permission of SARGENT Manufacturing is prohibited. Patent pending  
and/or patent [www.assaabloydss.com/patents](http://www.assaabloydss.com/patents)

**ASSA ABLOY, the global leader  
in door opening solutions**

# Table of Contents

Page

<b>1</b>	<b>Your Unique Signature Pattern .....</b>	<b>1</b>
<b>2</b>	<b>Protecting Your Signature Code Pattern.....</b>	<b>1</b>
<b>3</b>	<b>Signature Feature Description .....</b>	<b>2</b>
	How the Cylinder Parts are Modified.....	2
	The Signature Components.....	2
<b>4</b>	<b>Assembly of Signature Feature Inside the Cylinder .....</b>	<b>3</b>
<b>5</b>	<b>How Does the Signature Feature Work.....</b>	<b>3</b>
<b>6</b>	<b>Field Servicing the Signature Cylinder .....</b>	<b>4</b>
	Types of Servicing .....	4
	Pinning a New or Re-Combining Existing Signature Cylinders.....	4
<b>7</b>	<b>Blocking Bar Configuration.....</b>	<b>5</b>
<b>8</b>	<b>New Signature Pin Kit.....</b>	<b>6</b>
	Components of the New Signature Pin Kit.....	6
<b>9</b>	<b>Cutting Signature Keys.....</b>	<b>7</b>
	Lubrication.....	7
<b>10</b>	<b>Signature's Affect of the Master Key System.....</b>	<b>8</b>
<b>11</b>	<b>The Authorization Process .....</b>	<b>8</b>
<b>12</b>	<b>Acknowledgment Process.....</b>	<b>9</b>
<b>13</b>	<b>How to Order Signature Components .....</b>	<b>9</b>

Thank you for selecting SARGENT's Signature protected security cylinders and keys to protect the integrity of your facility and its master keying system.

This Information and Field Service Guide has been developed to assist you in understanding and servicing your SARGENT Signature cylinders and keys.

SARGENT has created your registered code pattern exclusively for your facility.

It is imperative that you protect this information so it remains confidential and known only to those individuals authorized by you and SARGENT's Key Records Department.

Again, thank you for selecting SARGENT Signature.

SARGENT Manufacturing Company reserves the right to make changes in design and specification or to make additions and improvements to the Signature cylinders and keys without notice and without obligation to incorporate them into previously manufactured products. SARGENT Manufacturing Company is not responsible for any non-SARGENT modifications, additions, or alterations to the Signature cylinders and keys.

## 1 Your Unique Signature Pattern

The SARGENT Signature Series protected cylinder and key program is a unique configuration of internal components within the cylinder barrel, body and dimpling on the key.

The blending of these components and machining processes provides SARGENT a vast number of unique individual patterns.

Your particular pattern has been chosen from that assortment.

In essence we have created individual keyways for a facility's Signature cylinders and keys.

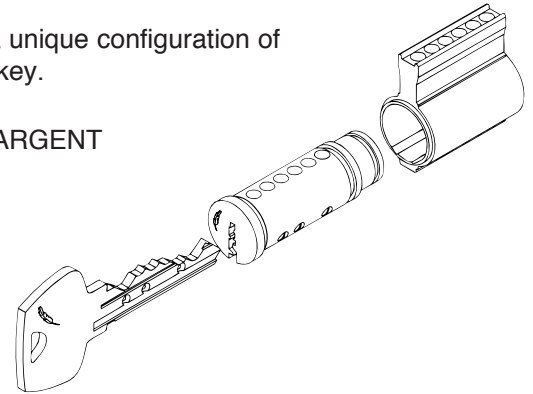

To further protect your Signature system, SARGENT assigns a Signature Series seven-digit code pattern.

That Signature configuration process is protected by the United States SARGENT is committed to restricting and controlling the distribution of these protected patterns.

Based upon a pre-defined geographical area, Signature code patterns will not be issued to any other facility within the agreed upon geographical boundaries.

Component parts containing your Signature code pattern (keys, complete cylinder assemblies and cylinder barrels) are only available for purchase through an authorized SARGENT distributor.

Please refer to the section entitled "How to Order Signature Components" for further information.

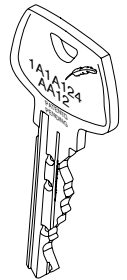

## 2 Protecting Your Signature Code Pattern

The dimple configuration on your Signature code pattern is milled into the key blank at the SARGENT factory. In order to maintain the control, security and integrity of your key system, it is vital to limit access to your Signature key blanks.

Whether you have your own internal lock and cylinder servicing capabilities or depend on an outside service, it is important that you place orders for your facility with an authorized SARGENT distributor for components containing the unique Signature pattern (keys, key blanks, cylinders, cylinder barrels). An updated record containing the name, contacts, and address of your selected servicing group must be on file at SARGENT with any changes reported to SARGENT on your letterhead.

For those in need of an outside service for cylinder keying, key cutting and system maintenance, please contact your SARGENT distributor.

### 3 Signature Feature Description

The SARGENT Signature feature is the interaction of unique components loaded into standard production cylinder parts modified to accept these components.

#### How are the Cylinder Parts Modified?

The parts which are modified to accommodate the Signature components are the cylinder barrel, cylinder body and key blank. Modifications of these parts involve: milling and drilling the cylinder barrel, broaching grooves in the barrel chamber of the cylinder body and drilling dimples on both sides of the key blanks.

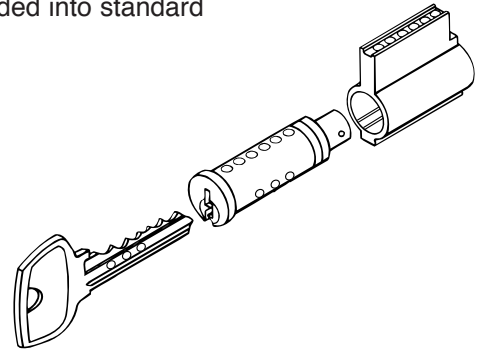

In order for the Signature feature to function, three holes are first drilled on each side of the Signature cylinder's barrel. The location of these drill holes creates the basis for the Signature pattern in both the cylinder and the key blank.

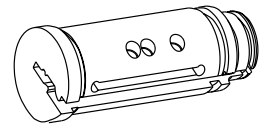

Two channels are then machined from front to back in the bottom of the cylinder barrel, one on each side of the keyway broaching.

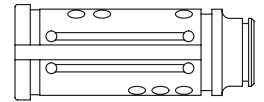



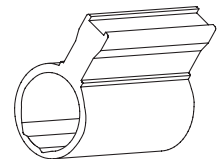

Two corresponding grooves are then machined in the bottom of the body.



#### What Are The Signature Components?

The components that make up the Signature feature are:

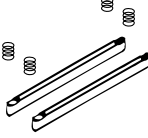
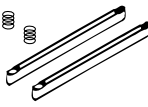
- A • six (6) Signature Side Pins 
- B • two (2) Keyway Blocking Pins 
- C • six (6) Side Pins and Keyway Blocking Pin Springs 
- D • six (6) Side Pins and Keyway Blocking Pin Caps 
- E • four (4) Blocking Bar Springs (part no. 13-0986) 
- F • two (2) Blocking Bars (part no.13-0985) or 13-1109 (see below) 

Order No. 13-0985  
For cylinders with patent pending on keys or Feather logo opposite key way on bow ("V" groove or no witness mark)



Order No. 13-1109  
For cylinders with patent No. 5,475,998 on keys or Feather logo above Patent (Radius groove)  
For cylinders with patent # 5,475,998 on key or "PAT." below Feather logo



**\*Note:** Parts A, B, and C are factory installed. Removal voids all warranty.

Copyright © 2007, 2011, 2014, 2016, Sargent Manufacturing Company, an ASSA ABLOY Group company. All rights reserved. Reproduction in whole or in part without the express written permission of Sargent Manufacturing Company is prohibited.

## 4 Assembly of Signature Feature Inside the Cylinder

The Signature feature operates independent of your cylinder's master key system.

The Signature feature provides two locking points within the cylinder in addition to the locking created by the master key system.

Each of the holes drilled into the cylinder barrel for the Signature feature contains a side pin or keyway blocking pin and a side pin/keyway or blocking pin spring. Each hole containing these Signature feature pins and springs sealed at the factory with a plug. This plug is never to be removed. Lubrication is applied at the time the Signature pins and springs are sealed in the barrel.

The Signature feature pins are not to be serviced in the field.

Tampering with the side pins, side pin springs or plugs may cause the Signature feature to fail and render your cylinder inoperable.

As a final step, two blocking bar springs and a blocking bar are inserted into channels on the bottom of the cylinder barrel. These bars have an offset and the orientation of the offsets within the cylinder barrel is determined by the depth of the dimples on the keys. Information on orienting the bars and placing them in the cylinder barrel is given in the section "Field Servicing the Signature Feature".

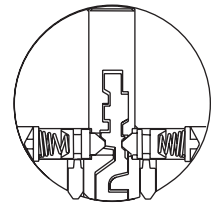
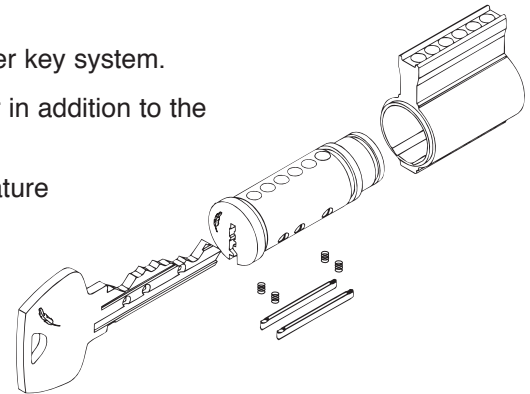

## 5 How Does the Signature Feature Work

The two blocking bars on the bottom of the cylinder barrel are pressed by the blocking bar springs into the grooves on the bottom of the barrel chamber in the cylinder housing. The side pins, which are above the blocking bars, keep the blocking bars from rising out of the grooves. This action along with the master keying pins in the top of the cylinder, keep the cylinder barrel from turning and the cylinder from operating.

There are six dimples in each key, three on each side. There are six side pins in each cylinder barrel, one for each dimple in the key. When the dimples and side pins are correctly aligned and the sizes of the pins correspond to the depths of the dimple cuts, the offsets in the blocking bars are aligned with grooves on the side pins, which is necessary for cylinder operation.

The following describes the interaction of the key and the cylinders:

When the correct Signature key (correct code pattern of dimples and master keying cuts) is inserted into the Signature cylinder:

- Side pins are pressed by the side pin springs into the dimples on the key
- Offsets in the blocking bars are then aligned with the grooves on the side pins
- Master keying pins are pressed by driver springs into the cuts on the top of the key creating a shear line at the top

The initial turning of the key and corresponding turning of the barrel results in:

- Blocking bars rising out of the grooves in the bottom of the barrel chamber
- Offsets in the blocking bars seating in the grooves on the side pins
- Key and cylinder barrel then turn freely inside the cylinder housing

## 6 Field Servicing the Signature Cylinder

### Types of Servicing

Over the course of time, there are several types of field servicing that the building owner may need to perform on the Signature cylinder.

- Pinning a new or re-combining an existing Signature cylinder
- Cutting Signature keys
- Lubrication

### Pinning a New or Re-combining Existing Signature Cylinders

Pinning new or re-combining existing Signature cylinders is accomplished in the same manner as any SARGENT pin tumbler cylinder.

Four basic steps are required to pin a Signature cylinder:

- 1) Load the barrel with bottom pins and master splits
- 2) Insert the Signature blocking bars and springs
- 3) Load the cylinder body with drivers and springs
- 4) Final assembly

When repinning a Signature cylinder, it may not be possible to remove all of the bottom pins and master splits with any one key. It may be necessary to dump the entire cylinder load including the drivers and springs.

When assembling the plug/barrel in a new or re-keying an existing Signature cylinder, it is not possible to contain all the bottom and master splits with any one key from the key system. The load key will assist you in inserting a fully loaded Signature plug into the loaded Signature cylinder's outer body. To make a load key, cut a key on the appropriate Master Key Section blank with all #0 (10) bittings. Remove the peaks between each cut.

As this key is cut to all #0 cuts, it will allow all of the bottom and master splits to be contained in the plug for easy assembly into the cylinder body.

Remember that the side pins and keyway blocking pins, side pin and keyway blocking pin springs and plugs do not require servicing and should not be disturbed. Recombining the master key pinning does not require disturbing the blocking bars or blocking bar springs (The tools provided in your Signature pinning kit are designed to avoid disturbing these parts unintentionally).

**Important:** Care is required when disassembling a Signature cylinder to insure that the Signature blocking bars and springs remain in place. Should the bars and springs fall out of the barrel, refer to instructions on how to replace these parts into the barrel.

## 7 Blocking Bar Configuration

SARGENT's Signature cylinder contains two (2) blocking bars.

The bar is placed so that the witness mark side of the bar is either toward the keyway broaching or away from the keyway broaching.

### GUIDE TO OFFSET BAR ORIENTATION

FOR KEYS WITH 1 & 2 DIMPLE DEPTHS (INBOARD BAR ORIENTATION)—FACE WITNESS MARK AWAY FROM KEY.

FOR KEYS WITH 3 & 4 DIMPLE DEPTHS (OUTBOARD BAR ORIENTATION)—FACE WITNESS MARK TOWARD KEY.

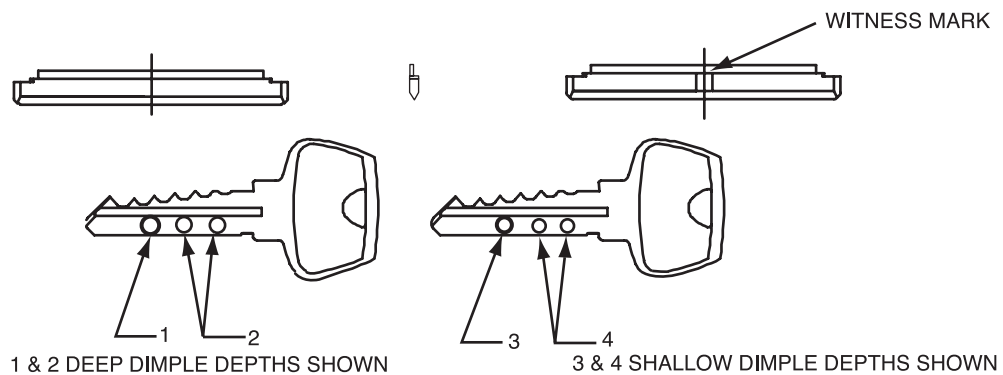

The position of the bars is determined by the last (seventh) digit of the Signature code pattern stamped on the keys to be used.

There are currently two sets of configurations (positions) assigned by the factory for a Signature code pattern. They are identified by the digit 4 or 2 as the seventh or last character of the Signature code pattern.

See the illustration below for the proper orientation of the bars.

If necessary, reinsert the four blocking bar springs (two for each blocking bar or one for each end of a blocking bar) and then the bars (in the correct configuration) as illustrated below.

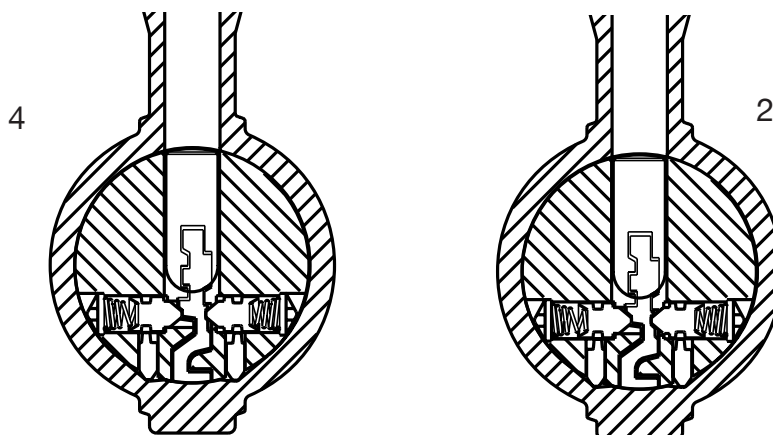
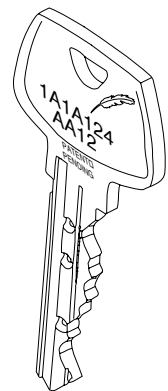

**8 Signature Pin Kit**

SARGENT has developed the Signature Series cylinder to be very simple to maintain and service. In keeping with this concept, SARGENT has a pin kit (catalog part #437S) and tools to assist in the field servicing of the Signature cylinder.

**Components of the Signature Pin Kit**

The pin kit contains 100 each of all the standard pins and springs required to accomplish pinning the master keying of the removable core cylinder. It also contains the necessary tools for assembling Signature featured cylinders.

When rekeying 10-6300 Signature Removable Core Cylinders, 437 RC/UL Rekeying Kit is needed in conjunction with 437S.

SARGENT created two types of barrel loading rods (part #13-1034, 13-1035). These followers are uniquely configured at each end to accommodate the different barrel configurations for the different types of Signature cylinders (mortise, rim, cylindrical).

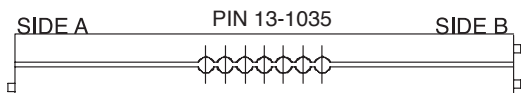

460 & 480 CYLINDERS (SIDE A)  
6300 R.C. RIM & MORTISE CYLINDERS (SIDE B)

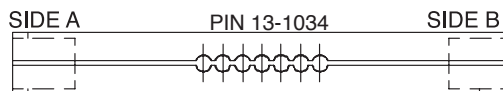

7, 8 & 9 LINE CYLINDERS (SIDE A)  
6, 10, 5500 & 6500 CYLINDERS (SIDE B)

The loading rods have also been machined to simplify the loading of the Signature cylinder outer body with driver pins and springs (a standard part of the master keying process).

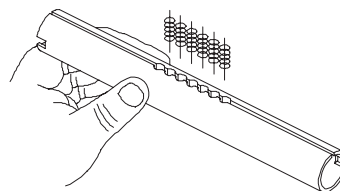
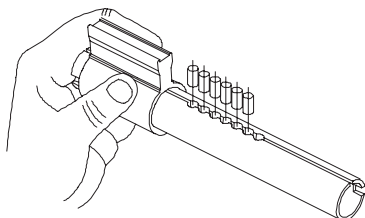

A spring depressing tool (part #13-1138) and a transfer knife (part #13-1037) are included to assist in transferring the driver and spring loads to the Signature cylinder body.

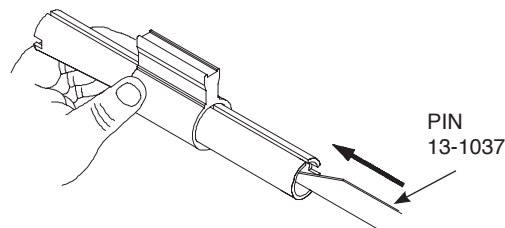
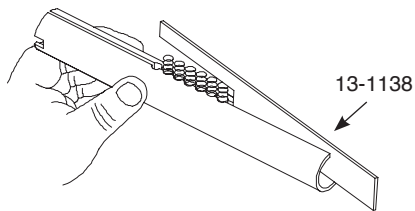

There is a set of tweezers with tips specially designed for picking up cylinder pins.

There is a field service tool (part #13-3916) that has been included to assist in loading or re-orienting the blocking bars.

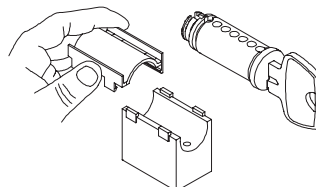
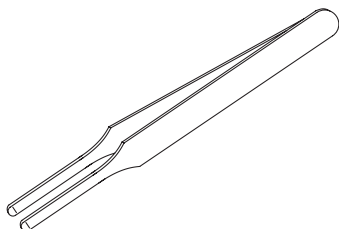

The blocking bars (part #13-0985 and 13-1109) and blocking bar springs (part #13-0986) are part of the Signature pinning kit.

Copyright © 2007, 2011, 2014, 2016, Sargent Manufacturing Company, an ASSA ABLOY Group company. All rights reserved. Reproduction in whole or in part without the express written permission of Sargent Manufacturing Company is prohibited.



## **9** Cutting Signature Keys

Signature protected key blanks in your assigned code key pattern are available only from the SARGENT factory or through an authorized SARGENT distributor.

(See section “How to Order Signature Components” for further details).

No special equipment is required for cutting new or copying existing key bittings onto the dimpled Signature key blanks. This process can be accomplished using any industry standard key cutting or duplicating equipment.

### **Lubrication**

Since the Signature side pins and side pin springs are assembled, lubricated and sealed at the factory, it is not necessary to service these components.

When lubrication is required, SARGENT recommends the use of SARGENT ASSA lube (P/N 18-0070) or spray lubricant such as “Poxylube” dryfilm lubricant CP-200.

Frequency of lubrication is dependent upon use when used on exterior doors.

Lubrication twice a year on normal use and more often for high use or exterior doors.

**Note:** It is important that you don't use liquid lubricants such as WD40. The use of solvent based liquid lubricants will create a gummy sludge within the cylinder and can affect the operation of the cylinder and its components.

## 10 Signature's Affect on the Master Key System

Your master key system is not affected by the Signature feature (other than making it more secure). As its functions are independent of the Signature feature, maintenance is no different than any other key system.

The separation between its function and the Signature features allows the end-user to introduce the Signature feature into most existing SARGENT factory-generated master key systems.

**Note:** While it may be possible to introduce the Signature feature into a field-generated master key system, it is necessary that the Keying Department at SARGENT review the system before agreeing to issue a Signature code key pattern for the system. Contact the Keying Department at SARGENT for further instructions on meeting this requirement.

## 11 The Authorization Process

SARGENT uses a computer software system that creates a PIN (Personal Identification Number) code to assure that we process only authorized orders for your facilities' Signature products.

When the Signature code pattern was initially registered, you should have received an acknowledgment containing your seven-digit code pattern and a PIN (Personal Identification Number) code. This PIN code should be used when placing an order with an authorized SARGENT distributor for any Signature components (cylinders, keys, key blanks, parts) for your facility. Once the PIN code has been used, a new one will be sent to the designated person(s) at your facility.

Every order for existing Signature products must have a Signature Code Pattern and meet one of the below criteria for security authorization:

- Valid PIN Code
- Letter of authorization from end user
- Product to be drop shipped to the same authorized end user on Letter of Authorization
- Copy of end users purchase order signed by the same person authorized in SARGENT's file

## 12 Acknowledgment Process

A new PIN code is generated as each new purchase order for your Signature products is processed, or a new PIN code will be generated upon the end user (system owner's) request.

An acknowledgment containing the new PIN code will be mailed directly to your facility from the factory. This acknowledgment will be sent via a mailing process and it will be addressed to the attention of the area and authorized person(s), on record at the SARGENT's Key Records Department. This letter should be signed by one of the authorized individuals who is to remain on our list of authorized person(s). The outside of the mailing envelope will be stamped "CONFIDENTIAL".

The information for the area responsible for the key system and the authorizing individuals must be kept current. If this information needs updating, please send a letter with any changes to the Key Records Department at SARGENT on the end user's letterhead.

## 13 How to Order Signature Components

All orders for Signature Components (cylinders, keys, key blanks, parts) must be placed through a factory authorized SARGENT distributor. Please include on your purchase order the following information:

- Signature seven-digit Code Pattern assigned to your facility
- The current PIN code assigned to your facility
- The zip code of the specific facility or building to which the Signature Code Pattern is assigned. The zip code is registered at the time your Signature Code Pattern is assigned

\* As an alternative to the PIN code authorization, SARGENT will accept a letter from the system owner with each order, signed by an authorized person, upon which the end user will grant the distributor written permission to order the Signature product.

If you need the name or address of a factory-authorized SARGENT distributor in your area, please call SARGENT at 800-727-5477.

SARGENT Manufacturing Company  
100 Sargent Drive  
New Haven, CT 06511 USA  
800-727-5477  
[www.sargentlock.com](http://www.sargentlock.com)

ASSA ABLOY is the global  
leader in door opening solutions,  
dedicated to satisfying  
end-user needs for security,  
safety and convenience