

Yale[®] KeyMark[®] Service Manual

Protected Keyway Cylinder



table of contents

The Security Leg®	2
Cylinder Exploded Views and Part Numbers	3-6
Parts Breakdown.	7
Pin Specifications	8
Pins and Pin Kits	9
Key Bitting Specifications	10
Key Cutting	11
Key Cutting Log	12
Combining Cylinders	13
Combining Worksheets	14-17
Master Keying	18-19

protected keyway

The Security Leg

The Yale KeyMark keyway has three distinct components: an upper portion or blade, a middle ledge, and a unique, lower angled portion or leg which exits the plug at an angle. This Security Leg keyway offers these advantages:

1. Keyway differentiation by angle;
2. Increased pick resistance;
3. Prevents other manufacturers' or other angle users' keys from entering the cylinder;
4. A unique and strong key with true key control;
5. A key blank of added thickness for extra strength and durability;
6. Prevents duplication of keys on standard key machines.

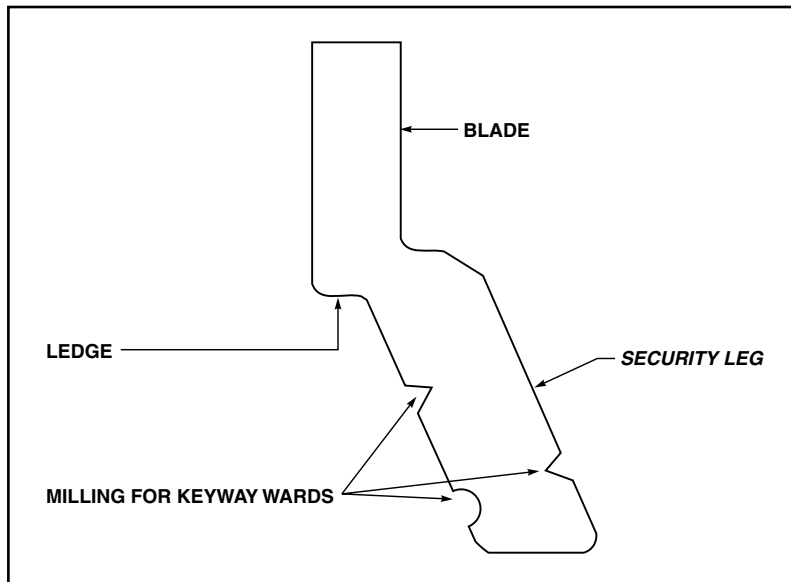

mortise/rim cylinders

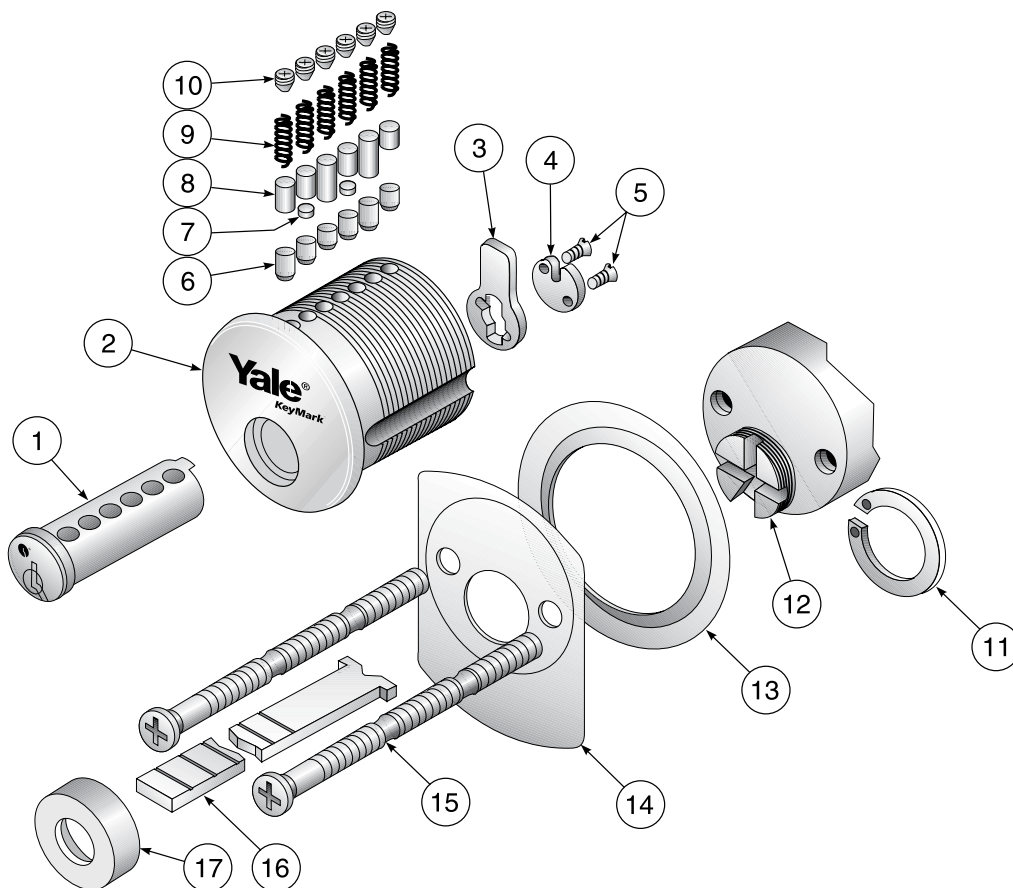

Item	Description	Qty.	Mortise Model No.	Rim Model No.	Remarks
1	Mortise Plug-.511"	1	K150	NA	Length, keyway and finish required
2	Shell	1	K151	K351	Finish required
3	Cam	1	KC1	NA	KC1 standard, refer to page 7 for options
4	Cam Washer	1	KP1	NA	
5	Cam Screw	2	KP2	NA	
6	Bottom Pins	.	.	.	Refer to page 9 for options
7	Top Pins (Master)	.	.	.	Refer to page 9 for options
8	Top Pins (Driver)	.	.	.	Refer to page 9 for options
9	Tumbler Springs	6 or 7	K730	K730	
10	Set Screws	6 or 7	K736	K736	
11	Plug Retainer	1	NA	K739	
12	Rim Plug-.511" Plug Diameter	1	NA	K350	Finish & keyway required
13	Collar	1	NA	KP4	Finish required
14	Mounting Plate	1	NA	Yale® Part	34-0010-1015-059
15	Mounting Screws	2	NA	Yale Part	34-2311-8738-048
16	Tailpiece (Break-off)	1	NA	KT1	Includes tailpiece retainer
17	Tailpiece Retainer	1	NA	.	Included with tailpiece

* See remarks.

small format interchangeable core

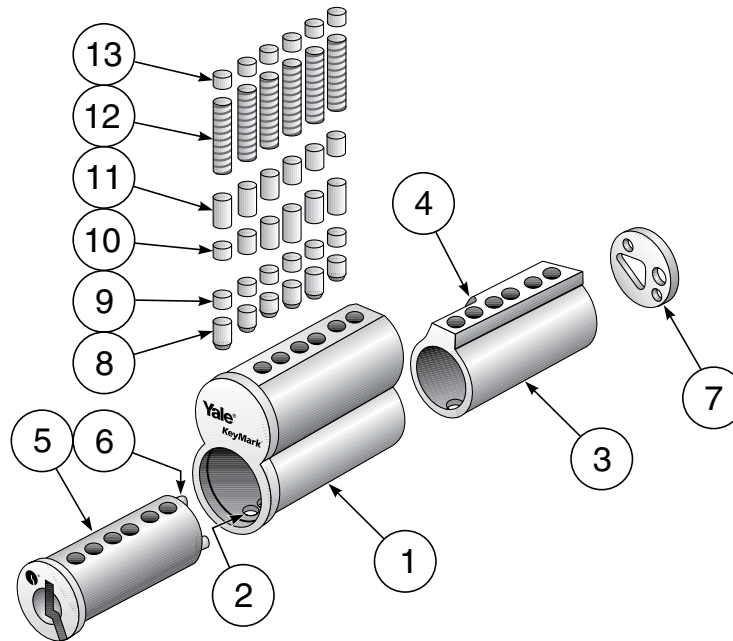

ITEM	Description	Qty.	Catalog No.	Remarks
1	Shell	1	..	Not available separately
2	Pin Ejector Holes	6 or 7	.	For location information only
3	Control Sleeve	1	..	Not available separately
4	Control Lug	1	..	Not available separately
5	Plug - .434" Plug Diameter	1	..	Not available separately
6	Rivet Posts	.	..	Not available separately
7	Key Stop Back Plate	1	..	Not available separately
8	Bottom Pins	.	.	Refer to page 9 for options
9	Top Pins (Master)	.	.	Refer to page 9 for options
10	Top Pins (Build-up)	.	.	Refer to page 9 for options
11	Top Pins (Driver)	.	.	Refer to page 9 for options
12	Tumbler Springs	6 or 7	K730	
13	Pin Chamber Caps	6 or 7	K731	

* See remarks.

**Parts included in K600, not available ordered separately.

large format interchangeable core

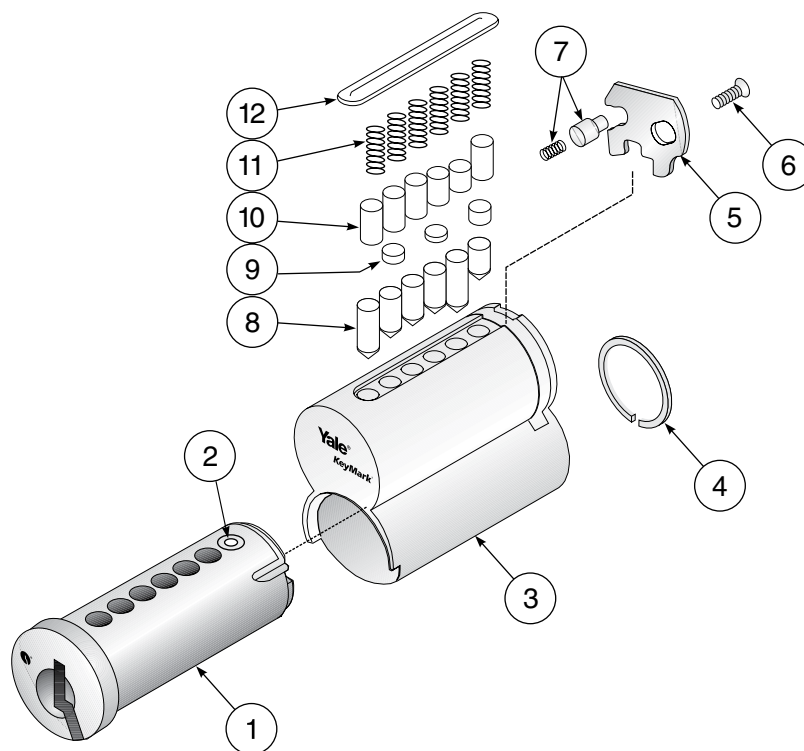

Item	Description	Qty.	Catalog No.	Remarks
1	Plug - .511" Plug Diameter	1	K850	No. of pins, keyway and finish required
2	Control Pin and Spring	1	.	Staked in place
3	Shell	1	K851	No. of pins and finish required Includes items 5, 6 and 7
4	Plug Retainer	1	K740	
5	Control Lug	1	.	Not available separately
6	Control Lug Retainer Screw	1	.	Not available separately
7	Control Lug Guide Pin and Spring	1	.	Not available separately
8	Bottom Pins	.	.	Refer to page 9 for options
9	Top Pins (Master)	.	.	Refer to page 9 for options
10	Top Pins (Driver)	.	.	Refer to page 9 for options
11	Tumbler Springs	6 or 7	K730	
12	Spring Cover, 6-pin	1	K732	
12	Spring Cover, 7-pin	1	K733	

* See remarks.

key-in-knob/lever cylinders

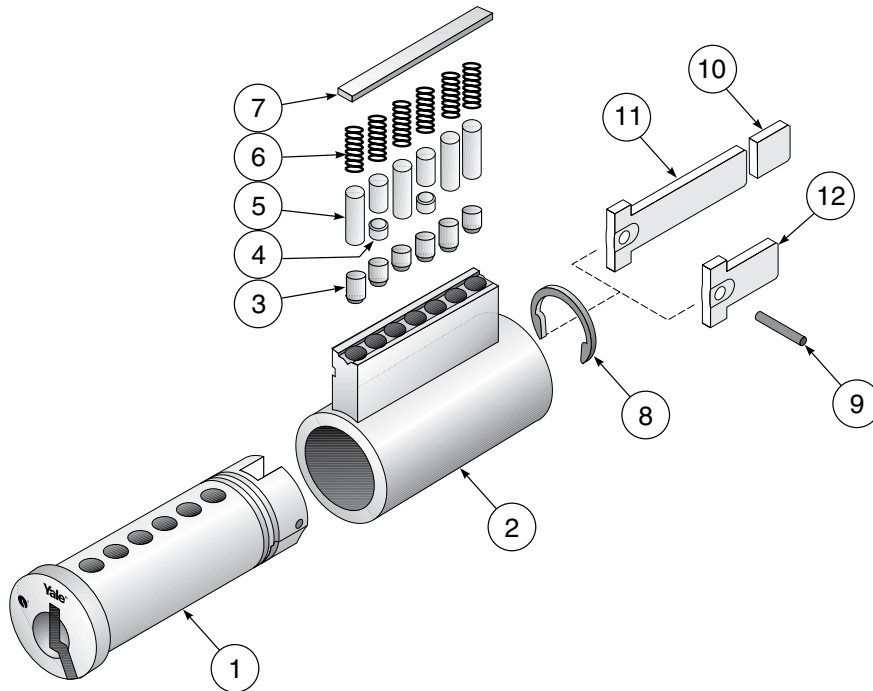

Item	Description	Qty.	Key-In-Knob Model No.	Key-in-Lever Model No.
1	Plug - .511" Plug	1	K450	K450
2	Shell	1	K451	K451
3	Bottom Pins	.	.	.
4	Top Pins (Master)	.	.	.
5	Top Pins (Driver)	.	.	.
6	Tumbler Springs	6 or 7	K730	K730
7	Spring Cover, 6-pin	1	K734	K734
7	Spring Cover, 7-pin	1	K735	K735
8	Plug Retainer	1	K741	K741
9	Roll Pin	1	NA	Yale® Part
10	Tailpiece	1	NA	KT2
11	Tailpiece	1	NA	KT7
12	Tailpiece	1	NA	KT3

Note: Tailpiece length varies by function and application.

* See remarks.

Auxiliary Cylinders (Not Illustrated)

The items in the chart at right are specific to auxiliary cylinders. Item numbers 2 through 8 above are also included.

Description	Qty.	Model No.	Remarks
Plug	1	K251	Used with K200
Tailpiece	1	KT4	Used with K200
Tailpiece	1	KT6	Used with K290 only
Cylinder Collar	1	Yale Part	14-3511-1013-048
Lazy Cam	1	Yale Part	14-3511-6102-082
D-Ring	1	Yale Part	14-3511-1014-048

Note: Tailpiece length varies by function and application.

parts breakdown

Cylinder Parts			
Number	Description	Used With	Remarks
K730	Tumbler Springs	All types	
K731	Pin Chamber Caps	K600	SFIC
K732	Spring Cover, 6-pin	K800	LFIC
K733	Spring Cover, 7-pin	K800	LFIC
K734	Spring Cover, 6-pin	K200/K400	Aux./KIK/KIL
K735	Spring Cover, 7-pin	K200/K400	Aux./KIK/KIL
K736	Set Screws	K100/K300	Mortise/Rim
K739	Plug Retainer	K300	Rim
K740	Plug Retainer	K800	LFIC
K741	Plug Retainer	K200/K400	Aux./KIK/KIL

Tailpieces		
Length Varies by Function and Application		
Number	Used With	Remarks
KT1	K300/K840	Rim/LFIC Rim
KT2	K402	6-pin KIL
KT3	K404	KIL
KT4	K200	Auxiliary
KT5	K490	Schlage® KIL Kit
KT8	K202	6-Pin Interconnected Lock

Plugs		
Length, Keyway and Finish Required		
Number	Used With	Remarks
K150	K100	Mortise
K250	K200	Auxiliary
K350	K300	Rim
K450	K400	KIK/KIL
K850	K800	LFIC

Cams	
Number	Yale Reference
KC1	2160
KC2	2130
KC3	1161/Schlage Straight
KC4	1160
KC5	1161 (AR)
KC6	1161G (Key Switch)
KC7	Schlage Cloverleaf
KC8	Corbin Russwin Cloverleaf (A01)
KC9	Sargent® Straight
KC10	Yale® Affinity®

Shells		
Length and Finish Required Where Applicable		
Number	Used With	Remarks
K151	K100	Mortise
K351	K300	Rim
K451	K200/K400	Aux./KIK/KIL

Cam Accessories	
Number	Description
KP1	Cam Washer
KP2	Cam Screws

Lubrication

Yale® KeyMark® cylinders are lubricated from the factory with a Teflon® lubrication. Cylinders should be lubricated periodically depending upon environmental conditions and usage. LAB Lube is the approved lubricant.

Caution: It is not recommended to lubricate cylinders with oil or to mix lubricants.



pin specifications

Yale® KeyMark® cylinders use selected top and bottom pins that are spool type for added security. While other manufacturers' pin kits can be used with Yale KeyMark cylinders, the strict tolerances of pins and the added security from the spool pins are good reasons to use original Yale KeyMark pins. Also, use of non-factory original pins can void the warranty.

To minimize the possibility of decoding the cylinder combination by reading the color of the pins, never use colored replacement pins.

Bottom pins are made of high-quality nickel silver. This distributes wear evenly between the key and the pins.

Top, build-up and master pins are made of brass.

- Pin increment is .0125"
- Pin diameter is .1085"
- Bottom pin tip flat is .015"
- Bottom pin crown is 45° x .008"; Top pin crown is 30° x .008"
- Total stack height is:
 - .3975" for small format interchangeable core cylinders (23)
 - .2375" for non-small format interchangeable core cylinders (19)

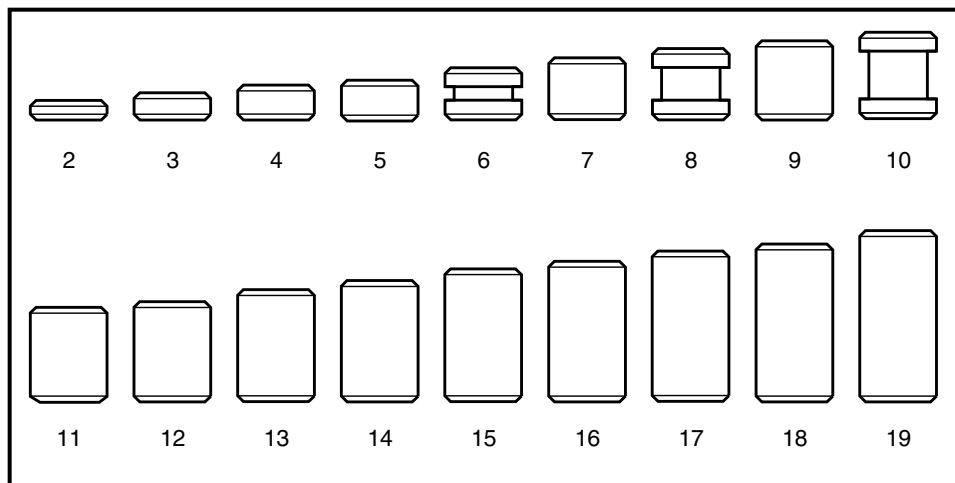

Master, Build-up and Top Pins

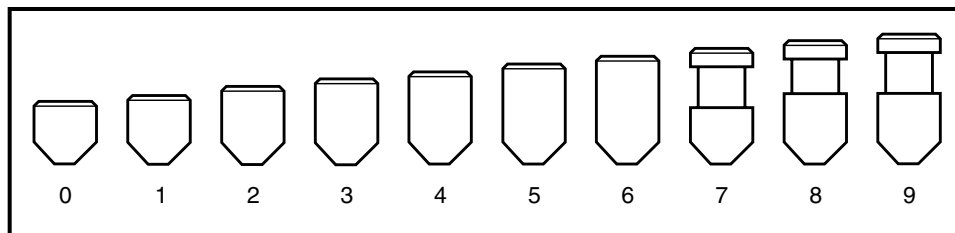

Bottom Pins

Master, Build-up & Top Pins		
Size	Length	Model Number
2	.025"	K702
3	.037"	K703
4	.050"	K704
5	.062"	K705
6 (Spool)	.075"	K706
7	.087"	K707
8 (Spool)	.100"	K708
9	.112"	K709
10 (Spool)	.125"	K710
11	.137"	K711
12	.150"	K712
13	.162"	K713
14	.175"	K714
15	.187"	K715
16	.200"	K716
17	.212"	K717
18	.225"	K718
19	.237"	K719

Bottom Pins		
Size	Length	Model Number
0	.110"	K720
1	.122"	K721
2	.135"	K722
3	.147"	K723
4	.160"	K724
5	.172"	K725
6	.185"	K726
7 (Spool)	.197"	K727
8 (Spool)	.210"	K728
9 (Spool)	.222"	K729

pin kits

K918

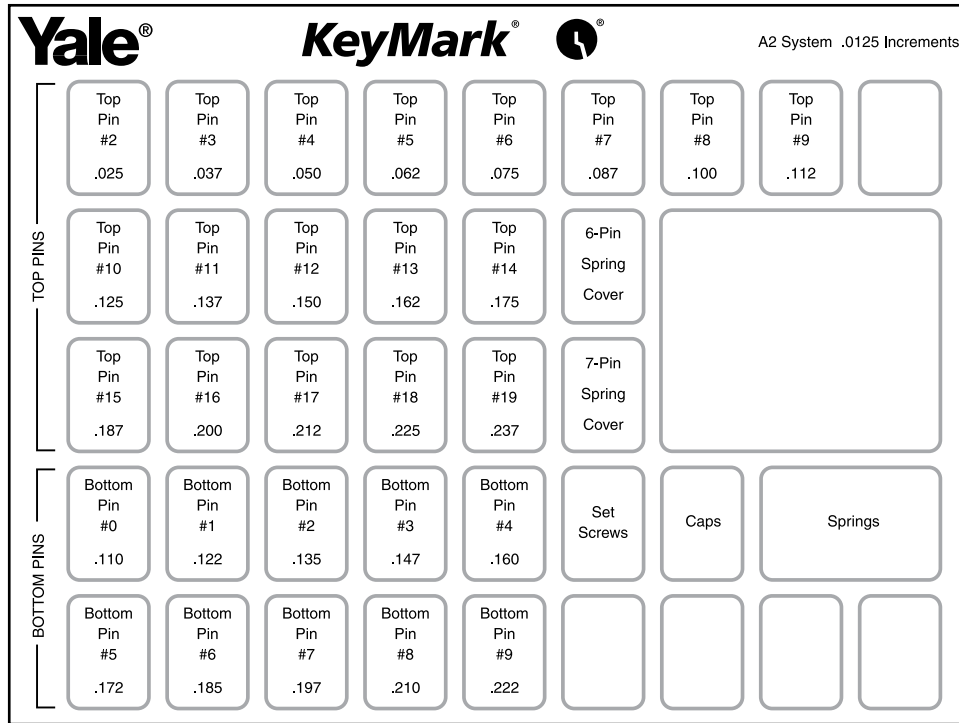

Length	Bottom	Master Build-Up Top	Pin Kit Qty.
.025"		2	100
.037"		3	100
.050"		4	100
.062"		5	100
.075"		6	100
.087"		7	100
.100"		8	100
.110"	0		100
.112"		9	100
.122"	1		100
.125"		10	100
.135"	2		100
.137"		11	100
.147"	3		100
.150"		12	100
.160"	4		100
.162"		13	100
.172"	5		100
.175"		14	100
.185"	6		100
.187"		15	100
.197"	7		100
.200"		16	100
.210"	8		100
.212"		17	100
.222"	9		100
.225"		18	100
.237"		19	100

Pin Kit Contents			
Description	Model Number	Pin Kit	Used With
Tumbler Springs	K730	100	All
Pin Chamber Caps	K731	25	K600
Spring Cover, 6-pin	K732	25	K800
Spring Cover, 7-pin	K733	25	K800



key biting specifications

Applies to all Yale® Keymark® keyways

"A2" PINNING SPECIFICATIONS

MACS: 9

Increment:	.0125"
Progression:	Two Step
Blade Width:	.310"
Depth Tolerance:	±0.0015"
Spacing Tolerance:	±0.0010"

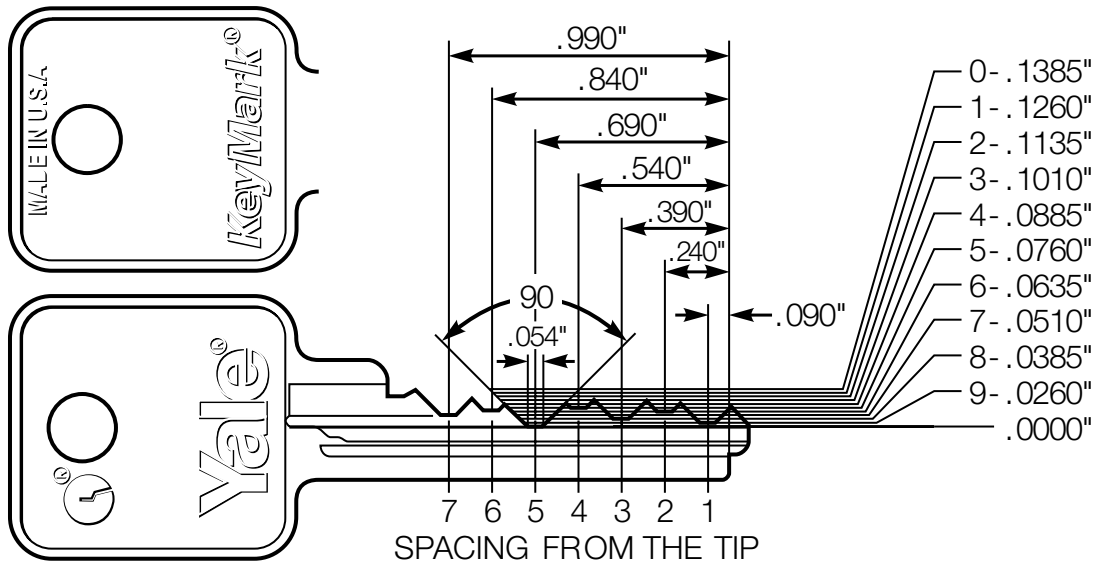
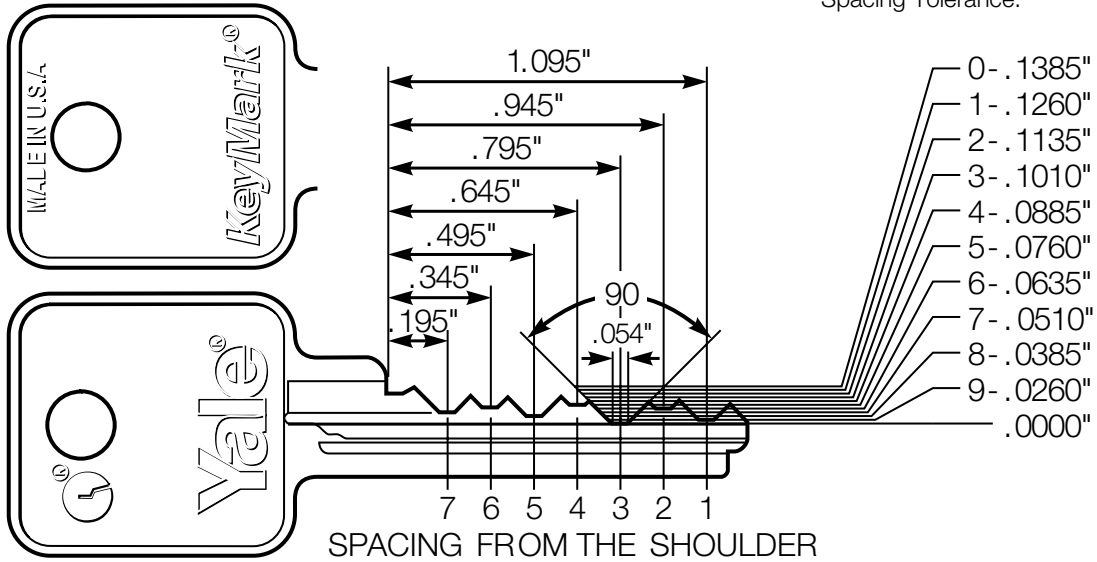

All Cuts Are Read and Written TIP to BOW

All depths are referenced from the offset or ledge of the key rather than from the bottom of the blade.

key cutting

K900 Code Cutting Punch

- Automatic Key Advance
- Interchangeable Vise Assembly

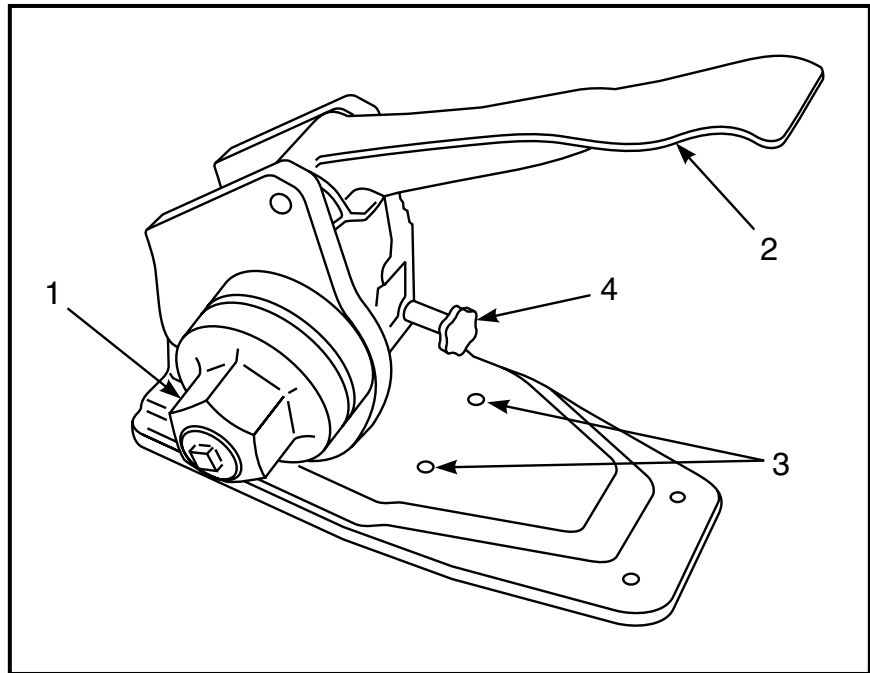

- | | |
|------------------|-------------------|
| 1. Depth Knob | 3. Mounting Holes |
| 2. Paddle Handle | 4. Vise Assembly |

Keys should only be cut using the Yale® KeyMark® K900 Code Cutting punch or other approved machines. These machines and special vises are only available through *Yale*.

Each code punch machine is designed to cut only the unique angle of *Yale Keymark* keys.

Any inserts or jaws for other machines, available in the future, will also only be available through *Yale*.

The K900 Code Cutting Punch can rest on a work bench or it can be mounted securely to the bench by means of the two mounting holes located in the base.

Note: The code punch uses a tip reference and all keys are cut tip to bow. LFIC Control Keys are furnished pre-cut in the tip position. When referencing the bitting list, the “0” cut used on the tip bitting is only to advance the vise one position.

When cutting these keys:

1. Insert the keyblank into the vise assembly.
2. Turn the depth knob to “0” and depress the paddle handle.

This will advance the vise assembly to the correct starting position for cutting the key.

3. Continue with cutting the key depths.

combinating cylinders

Calculating the “A2” Pin Stack

Rules For Top Loading

K600 (SFIC) Cylinders

For best results, pin the cylinder one chamber at a time.

- Pin the cylinder to the operating keys – change key(s) and master keys(s) – using bottom and master pins
- Pin the cylinder to the control key by inserting a “build-up pin” in each chamber. To determine the build-up pin numbers:
 - Add 10 to each of the control key cuts. This is called the “control total”;
 - For each chamber, subtract the bottom pin and master pin total (plug total) from the control total;
 - Use the resulting number as your build-up pin number.
- Load the top pin. To determine the top pin number, subtract the control total from 23. Reference the “Quick Subtraction Chart” for quick calculation (see page 15).
- The total stack height (the sum of all the pins) must equal 23.
- After all chambers have been pinned, insert the core into the capping block, load springs, and cap.

Rules For Top Loading K100/K200/K300/K400/K800 (Non-SFIC) Cylinders

For best results, pin the cylinder one chamber at a time.

- Pin the cylinder to the operating keys – change key(s) and master keys(s) – using bottom and master pins
- Load the top pin. To determine the top pin number, subtract the bottom pin and master pin total (plug total) from 19. Reference the “Quick Subtraction Chart” for quick calculation (see page 17).
- The total stack height (the sum of all the pins) must equal 19.
- After all chambers have been pinned, insert the core/cylinder into the capping block, load springs, and cap.

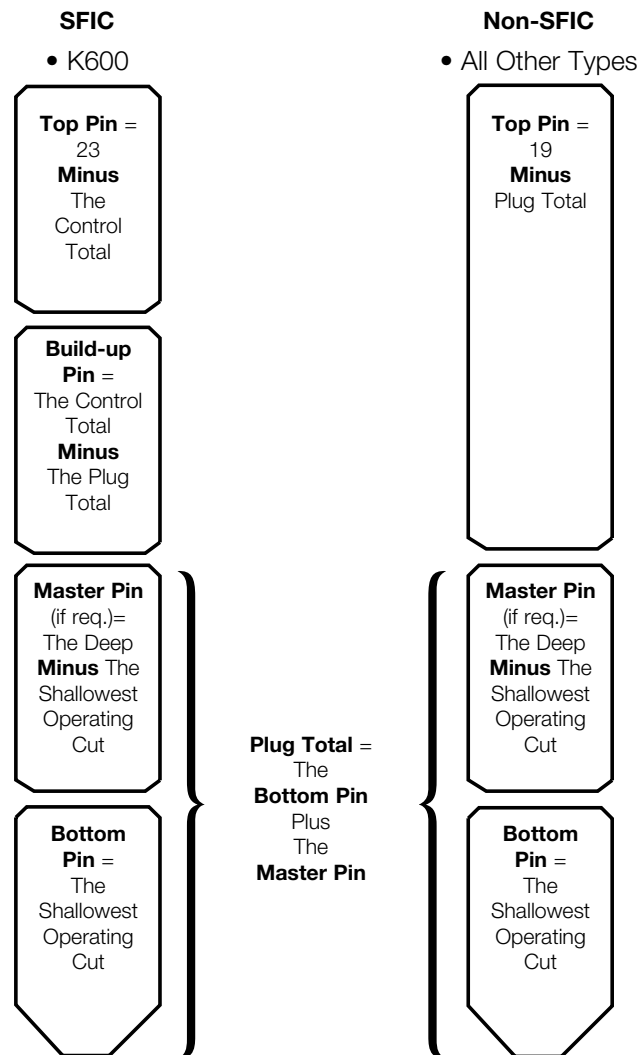

See page 14 & 15 for completed sample and blank combinating worksheets of SFIC cylinders.

See page 16 & 17 for completed sample and blank combinating worksheets of Non-SFIC cylinders.

combinating worksheet: K600 (SFIC)

Completed Sample

CALCULATION				CHAMBERS						
				TIP						
OPERATING KEYS				1	2	3	4	5	6	7
	01	GGMK	Insert Bitting	—	—	—	—	—	—	—
	02	GMK A	Insert Bitting	3	4	9	5	0	6	
	03	MK AA	Insert Bitting	5	2	9	5	0	6	
	04	CK AA	Insert Bitting	5	2	1	1	2	6	
P1»	05	Bottom Pin	[Shallowest Operating Cut]	3	2	1	5	0	6	
P2»	06	Master Pin	[Deepest Minus Shallowest Operating Cut]	2	2	8	2	2	X	
	07	Plug Total	[Master Plus Bottom Total]	5	4	9	1	2	6	
CONTROL KEY										
	C1	Control Cut	Insert Bitting	1	6	5	9	8	2	
	C2	Control Total	[Add 10 to C1]	11	16	15	19	18	12	
BUILD-UP PIN										
	B1	Control Total	[C2]	11	16	15	19	18	12	
	B2	Plug Total	[07]	5	4	9	1	2	6	
P3»	B3	Build-up Pin	[Subtract B2 from B1]	6	12	6	12	16	6	
TOP PIN										
	T1	Stack Height	[Pre-set]	23	23	23	23	23	23	23
	T2	Control Total	[B1]	11	16	15	19	18	12	
P4»	T3	Top Pin	[Subtract T2 from T1]	12	7	8	4	5	11	
PINNING SET UP										
(T3)	P4»	Top Pin		12	7	8	4	5	11	
(B3)	P3»	Build-up Pin		6	12	6	12	16	6	
(06)	P2»	Master Pin		2	2	8	2	2	X	
(05)	P1»	Bottom Pin		3	2	1	5	0	6	

To verify: P1, P2, P3 & P4 in each chamber must add up to 23.



combinating worksheet: K600 (SFIC)

Blank Worksheet

CALCULATION				CHAMBERS						
				TIP						
OPERATING KEYS				1	2	3	4	5	6	7
	01	GGMK	Insert Bitting							
	02	GMK	Insert Bitting							
	03	MK	Insert Bitting							
	04	CK	Insert Bitting							
P1»	05	Bottom Pin	[Shallowest Operating Cut]							
P2»	06	Master Pin	[Deepest Minus Shallowest Operating Cut]							
	07	Plug Total	[Master Plus Bottom Total]							
CONTROL KEY										
	C1	Control Cut	Insert Bitting							
	C2	Control Total	[Add 10 to C1]							
BUILD-UP PIN										
	B1	Control Total	[C2]							
	B2	Plug Total	[07]							
P3»	B3	Build-up Pin	[Subtract B2 from B1]							
TOP PIN										
	T1	Stack Height	[Pre-set]	23	23	23	23	23	23	23
	T2	Control Total	[B1]							
P4»	T3	Top Pin	[Subtract T2 from T1]							
PINNING SET UP										
	(T3)	P4»	Top Pin							
	(B3)	P3»	Build-up Pin							
	(06)	P2»	Master Pin							
	(05)	P1»	Bottom Pin							

To verify: P1, P2, P3 & P4 in each chamber must add up to 23.

Quick Subtraction Chart

Minus	1	2	3	4	5	6	7	8	9	10	11	12	13	14	15	16	17	18	19	20	21	22	23
23	22	21	20	19	18	17	16	15	14	13	12	11	10	9	8	7	6	5	4	3	2	1	0

combinating worksheet: K100/K200/K300/K400/K800 (Non-SFIC) ———

Completed Sample

CALCULATION				CHAMBERS						
				TIP						
OPERATING KEYS				1	2	3	4	5	6	7
	01	GGMK	Insert Bitting	—	—	—	—	—	—	—
	02	GMK <i>A</i>	Insert Bitting	3	4	9	5	0	6	
	03	MK <i>AA</i>	Insert Bitting	5	2	9	5	0	6	
	04	CK <i>AA</i>	Insert Bitting	5	2	1	1	2	6	
P1»	05	Bottom Pin	[Shallowest Operating Cut]	3	2	1	5	0	6	
P2»	06	Master Pin	[Deepest Minus Shallowest Operating Cut]	2	2	8	2	2	X	
	07	Plug Total	[Master Plus Bottom Total]	5	4	9	1	2	6	
TOP PIN										
	T1	Stack Height	[Pre-set]	19	19	19	19	19	19	19
	T2	Control Total	[07]	5	4	9	1	2	6	
P4»	T3	Top Pin	[Subtract T2 from T1]	14	15	10	12	17	13	
PINNING SET UP										
(T3)	P3»	Top Pin		14	15	10	12	17	13	
(06)	P2»	Master Pin		2	2	8	2	2	X	
(05)	P1»	Bottom Pin		3	2	1	5	0	6	

To verify: P1, P2 & P3 in each chamber must add up to 19.



combinating worksheet: K100/K200/K300/K400/K800 (Non-SFIC) ———

Blank Worksheet

CALCULATION				CHAMBERS						
				TIP						
OPERATING KEYS				1	2	3	4	5	6	7
	01	GGMK	Insert Bitting							
	02	GMK	Insert Bitting							
	03	MK	Insert Bitting							
	04	CK	Insert Bitting							
P1»	05	Bottom Pin	[Shallowest Operating Cut]							
P2»	06	Master Pin	[Deepest Minus Shallowest Operating Cut]							
	07	Plug Total	[Master Plus Bottom Total]							
TOP PIN										
	T1	Stack Height	[Pre-set]	19	19	19	19	19	19	19
	T2	Control Total	[07]							
P4»	T3	Top Pin	[Subtract T2 from T1]							
PINNING SET UP										
(T3)	P3»	Top Pin								
(06)	P2»	Master Pin								
(05)	P1»	Bottom Pin								

To verify: P1, P2 & P3 in each chamber must add up to 19.

Quick Subtraction Chart

Minus	1	2	3	4	5	6	7	8	9	10	11	12	13	14	15	16	17	18	19
19	18	17	16	15	14	13	12	11	10	9	8	7	6	5	4	3	2	1	0



master keying

Standard Key Coding System

Standard Master Key System: 2 Levels of Keying

Master key is assigned two letters. Change key numbers come before the MK letters.

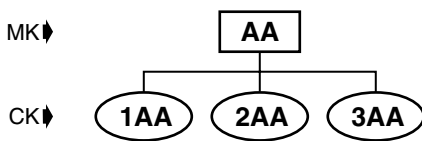

Grand Master Key System: 3 Levels of Keying

Grand master key is assigned one letter. Masters under the GMK are assigned two letters, the first being the same as the GMK letter. Change key numbers come after the MK letters.

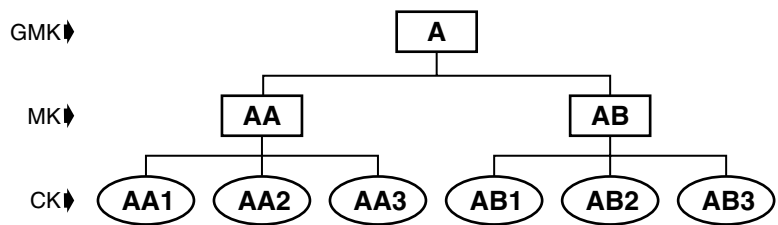

Great Grand Master Key System: 4 Levels of Keying

Great grand master key has the symbol of GGM. Grand master keys are each assigned one letter. Masters under the GMK are assigned two letters, the first letter being the same as the GMK letter. Change key numbers come after the MK letters.

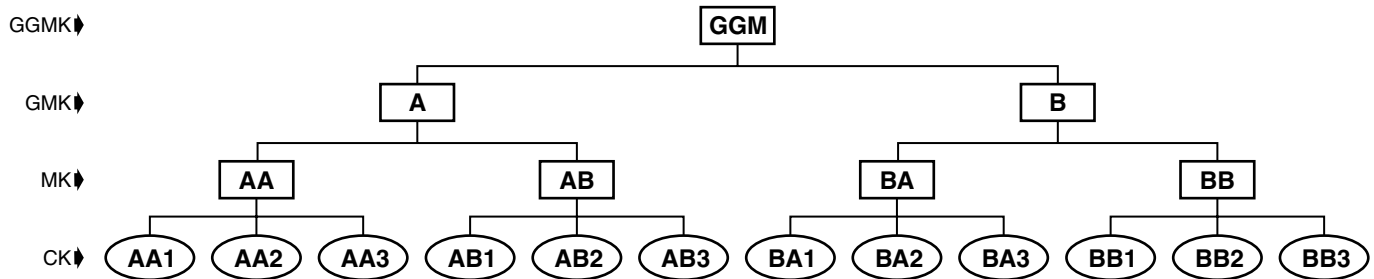

Special Keying Situations

Cylinder is operated by the change key and GMK, but no MK: Change key numbers come after the single GMK letter. Example: A1, A2, B1, etc.

Cylinder is operated by change key and GGM only, but no GMK or MK: Use symbols GGM1, GGM2, etc.

Cylinder is operated by one of the system's change keys but no MK's of any level: Suffix "(NMK)" to the regular symbol. Example: 3AA(NMK), AA7(NMK), etc.

Cylinder is operated by no keys in the system other than its own individual key: Single keyed sets SKD1, SKD2, etc.



master keying

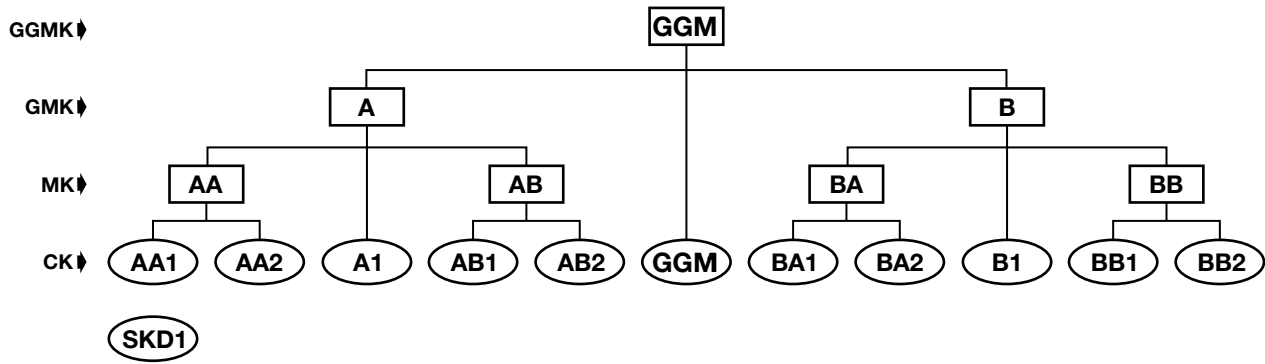

Master Key System Specifications

Refer to page 10 for the Key Bitting Specifications.

Expansion Specifications

Yale® KeyMark® systems should include expansion specifications which indicate the maximum planned quantity of theoretical bitting combinations needed at each level of keying. The expansion specification is the arithmetic expression of the expansion in the form of numbers separated by dashes. Each number refers to the level of keying system to which it relates.

Examples:

For a 2-level system requiring fifty change keys, the expansion specification would be: 1-50

For a 3-level system requiring two masters under the grand and forty change keys under each master, the expansion specification would be: 1-2-40

For a 4-level system requiring three grands each with ten masters with fifty changes, the expansion specification would be: 1-3-10-50

The number of changes needed directly operated by the GGM or GM is indicated in parenthesis after that level's specification. For example: 1(10)-4-75 would be read "one grand master with four masters under the grand, seventy-five changes under each master, and ten changes directly under the grand master only."

The following charts are examples of master keying specifications for Yale KeyMark 6- and 7-pin master key systems:

		6-pin			
		GGM	GM	MK	CK
Level 2		⊘	⊘	1	4096
Level 3	A	⊘	1	4	1024
	B	⊘	1	16	256
	C	⊘	1	64	64
Level 4	A	1	4	4	256
	B	1	4	16	64
	C	1	16	16	16

		7-pin			
		GGM	GM	MK	CK
Level 2		⊘	⊘	1	16384
Level 3	A	⊙	1	4	4096
	B	⊘	1	16	1024
	C	⊘	1	64	256
Level 4	A	1	4	4	1024
	B	1	4	16	256
	C	1	16	16	64

online literature and templates

For the latest information on Yale Locks & Hardware products, visit our website at: www.yalelocks.com

Click on the “Product Information” button to find:

- Catalogs
- Parts manuals
- Templates
- Specifications
- Installation instructions

Yale® customers can click on the ebusiness symbol  on the website to register for an ebusiness account to:

- Check the status of orders
- Check availability of Quick-Ship items
- Track your order and confirm delivery
- Receive email notification of template changes
- And More...

Or contact us at:

U.S.A.

Yale Locks & Hardware

Address: 225 Episcopal Road, Berlin, CT 06037-4004 USA
 Tel: 1-800-438-1951 • Fax: 1-800-338-0965 • www.yalelocks.com

Canada:

ASSA ABLOY Door Security Solutions Canada

Address: 160 Four Valley Drive, Vaughan, Ontario L4K 4T9
 Tel: 1-800-461-3007 • Fax: 1-800-461-8989 • www.assaabloy.ca

International:

ASSA ABLOY Americas International

Tel: 1-905-821-7775 • Fax: 1-905-821-1429 • www.assaabloyai.com

Yale Locks & Hardware is a division of Yale Security Inc., an ASSA ABLOY Group company.

Yale® is a registered trademark of Yale Security Inc., an ASSA ABLOY Group company. KeyMark®, Medeco®, and Security Leg® are registered trademarks of Medeco Security Locks, Inc. Schlage® is a registered trademark of Schlage Lock Company. Sargent® is a registered trademark of Sargent Manufacturing Company. Other products' brand names may be trademarks or registered trademarks of their respective owners and are mentioned for reference purposes only. These materials are protected under U.S. copyright laws. All contents current at time of publication. Yale Security Inc. reserves the right to change availability of any item in this catalog, its design, construction, and/or its materials. Copyright © 2002, 2013, Yale Security Inc., an ASSA ABLOY Group company. All rights reserved. Reproduction in whole or in part without the express written permission of the Yale Security Inc., an ASSA ABLOY Group company, is prohibited.

YALE, with its unique global reach and range of products, is the world's favorite lock.

ASSA ABLOY is the global leader in door opening solutions, dedicated to satisfying end-user needs for security, safety and convenience.