

# The National Locksmith

July 2004  
Volume 75  
No. 7  
\$7.00

Shop the online store!  
[TheNationalLocksmith.com](http://TheNationalLocksmith.com)

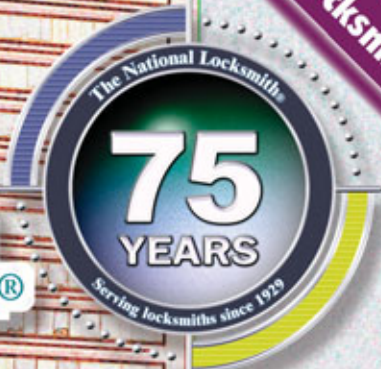

**STRONG ARM SECURITY**



**HPC, INC.**



**D & D TECHNOLOGIES (USA), INC.**



**ASSA, INC.**



**LAGARD, INC.**



## ALOA '04 BALTIMORE, MD

see  
the hottest  
products in the  
industry!



# Blitz® Family Hot Summer Savings!

Super Low  
Sale Prices!

Made in  
the USA!



## Base Model Blitz®

No. 1200B  
(all voltages)

## The Original Blitz®

No. 1200CMB  
(all voltages)

## Extreme Blitz®

No. 1200CMBX  
(all voltages)

Ask your Authorized HPC Distributor for their Super Low Sale Price!

- No Cutters

- No Code Cards

- No Software

Great choice for a dedicated or second Blitz® machine. Includes machine only. For use with your existing cards and cutters.

- 2 Cutters

CW-1011, CW-14MC

- 150 Code Cards

- CodeSource® Lite\*

(\$595.00 value)

Over 25 years of proven technology has made HPC's Blitz® "the Standard of the Industry". Its revolutionary needle-point accuracy earned it two U. S. Patents.

- 3 Cutters

CW-1011, CW-14MC, CW-47MC

- 175 Code Cards

- CodeSource® Plus\*

(\$595.00 value. Includes Code Card Generating Software)

- MasterKing®  
Combo Pack\*

(Includes How to Master Key)

- Tubular Key Adapter
- Calibration Kit

For the locksmith who wants it all! The Extreme Blitz® offers a total package. Perfect for a new locksmith, a new van, or a new shop.



HPC, Inc.  
3999 N. 25th Avenue  
Schiller Park, IL 60176 USA  
Tel: 847.671.6280  
Fax: 847.671.6343  
www.hpcworld.com

To provide you with the most up-to-date information, software will be sent directly to you upon receipt of your registration card. CodeSource® Lite is one of the three optional gifts available with the Original Blitz®.

**On The Cover...**

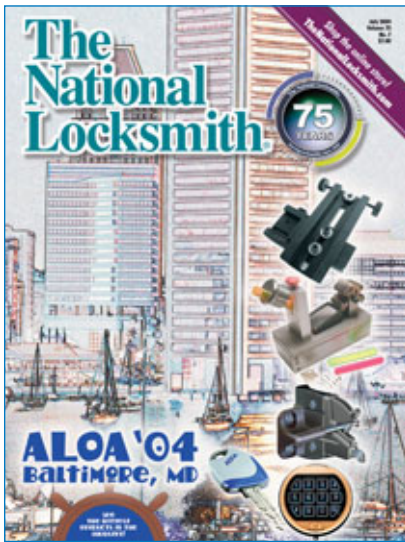

The 2004 ALOA convention in Baltimore, Maryland will feature several new products this year such as those by Strong Arm, HPC, D&D Technologies, ASSA, and LaGard.

**Publisher** ..... Marc Goldberg  
**Editor** ..... Greg Mango  
**Art Director** ..... Jim Darow  
**Technical Editor** ..... Jake Jakubowski  
**Senior Writers**  
 Sal Dulcamaro CML, Michael Hyde,  
 Dale Libby CMS, Dave McOmie, Sara Probasco,  
 Robert Sieveking  
**Contributing Writers**  
 John Blankenship, Tony Blass,  
 Ron & Chris Curry, Mark Daniel,  
 Richard Allen Dickey, Ken Holmlund,  
 Tom Lynch, Tom Mazzone, Randy Mize,  
 Tom Seroogy, Steve Young  
**Director of Sales & Marketing** ..... Jeff Adair  
**Advertising Account Manager** ..... Debbie Schertzing  
**Accounting Manager** ..... Sheila Campo  
**Production Assistants** ..... Dave Krolf, Joseph Bonus  
**Administrative Assistants** ..... LaVerne Schertzing, Sean Selby, Chandra Smith  
**Shipping Manager** ..... Allan Galvez

**National Publishing Company**  
 The National Locksmith® ISSN #0364-3719 is published monthly by the National Publishing Co., 1533 Burgundy Parkway, Streamwood, Illinois 60107-1861. Periodicals postage paid at Bartlett, Illinois 60107 and additional mailing offices USPS 040110. Subscriptions \$46.00 per year in the USA; \$58.00 per year in Canada; \$72.00 in all other countries. Single copies \$7.00 each. Postmaster, please send change of address to National Publishing Co., 1533 Burgundy Parkway, Streamwood, Illinois 60107-1861.  
 ©2004 by the National Publishing Company.  
 All rights reserved. Printed in the U.S.A.



(630) 837-2044 • Fax: (630) 837-1210  
 E-Mail: natlock@aol.com  
 See us on the World-Wide Web:  
[www.TheNationalLocksmith.com](http://www.TheNationalLocksmith.com)

# CONTENTS

The National Locksmith®

July 2004 • Vol. 75, No. 7

## FEATURES

**12** **COVER FEATURE**  **84**  
**ALOA Showstoppers** **Major Rustification**

**42** **42**  **92**  
**2001 Toyota MR2, Part 2** **2002 Lincoln LS, Part 1**

**50**  **108**  
**PRO-LOK** **2003 BMW F650GS**  
**Car Opening Exposed**

**52**  **116**  
**Exploded View** **Open Forum**

**58**  **130**  
**The Evolution of the Blue Shark™** **Infiniti**

**62**  **156**  
**ASSA CLIQ** **Helping The Industry One House At A Time**

**68**  **160**  
**Securiton's iMXD** **Lockmasters Security Institute Expands Education Center**

**72**  **165**  
**Version 5.0 Electronic InfoBase Edition (LSS+)** **TheNationalLocksmith.com**

## DEPARTMENTS

- 5** **Commentary**
- 6** **Mango's Message**
- 8** **Letters**
- 76** **Beginner's Corner**
- 82** **The Lighter Side**
- 98** **Technitips**
- 128** **Business Briefs**
- 166** **Test Drive**



# THE CHOICE!

For Professional & Accurate Pinning



.261B.C.

.261B.C.

.2

.2

The Worlds Most Advanced  
Pinning Systems

PROVIDING THE SECURITY WORLD WITH QUALITY  
Lock Tumbler Pins, Repinning Kits, Security Tools

700 Emmett St., Bristol CT 06010 U.S.A. 1-800-243-8242 FAX 1-860-583-7838  
Website: [www.labpins.com](http://www.labpins.com) E-Mail: [labpins@labpins.com](mailto:labpins@labpins.com)

Circle 242 on Rapid Reply





## Is A "Poetry Tax" Next?

### Thank you Corbin Russwin...

Our June 2004 cover featured a lovely photograph of "Corbin Russwin Vineyard Collection." We forgot to thank the company for the image. So thank you to Corbin Russwin and YSG Door Security Consultants!

### Pay the taxman...and pay and pay

Beginning next month, Arkansans will begin paying more sales tax. The rate hasn't increased, but more goods and services have been added to the list of taxable items. The measure was passed during the Legislature's most recent special session as a way to pay for education reforms.

Among the items that will be taxed are: Garbage collection, including the collection of recyclable items; mosquito control; wrecker and towing services; dry cleaning and laundry services; camping or trailer spaces and locksmith services.

The collection of the tax will burden the business as well as the consumer, Allen said. "It makes it more difficult for customers to pay the taxes and it's more for me to have to pay an accountant to keep up with it."

Product has always been taxable, but now labor is as well. Locksmiths will have even more difficulty calculating taxes because the business travels from town to town, with varying tax rates in each of those towns.

### Locksmiths know what to do...

Tarla Thomas has a beef about cop service in Elk Grove, CA. Her 12-year-old nephew had an asthma attack at 1:30 a.m. Tarla and the lad made a quick trip to their all-night drugstore while the boy's brothers, ages 11 and 10, slept. Returning 15 minutes later, Tarla realized she had locked herself out of the house. "I called police and asked for help," Tarla said. "They said, 'What do you want us to do?' I thought that was rude." She called a locksmith. He knew what to do.

### Gas prices fuel cutbacks...

When people complain about high gasoline prices at Shazim Khan's Texaco station in Pompano Beach, FL, he sometimes shows them the wholesale price

he pays a distributor for gas. "I pay \$2 a gallon for regular, and I'm selling it for \$2.039," said Khan.

But the cost affects us all. "I'm getting hammered by fuel costs," said Dean Kallan, a locksmith and disc jockey who lives in Deerfield Beach. Kallan, who has two vans, currently spends about \$150 on gas weekly. His family has been forced to cut down on pleasure trips, food and other items at home.

### Famous locksmith also writes poetry...

U.S. poet August Kleinzahler, a former locksmith, has won one of the world's most prestigious poetry prizes, Canada's \$29,200 Griffin Prize, for his book, "The Strange Hours Travelers Keep."

Kleinzahler, who hails from New Jersey but has lived in San Francisco for the past 24 years, won Thursday in the Griffin's international category over 422 other books. The prize is awarded annually for the best books of poetry published in English the previous year.

*Publishers note: Hey, Mr. Kleinzahler isn't the only locksmith who can rhyme. Here's my ode to this locksmith...who also happens to write poems.*

*When I suffer from writer's block.*

*I simply think about a lovely lock.*

*Though word and phrase I may bumble,*

*I know a wafer from a pin tumbler.*



*Marc Goldberg*

**Have questions? Want free technical help?  
Free Locksmith Forums!**

[www.TheNationalLocksmith.com](http://www.TheNationalLocksmith.com)

**Marc Goldberg**  
Publisher



# Mango's Message

## Bank ATMs Converted To Steal IDs

**A**TM card readers and CCTV cameras to retrieve PINs was found installed on legitimate bank ATMs in Austin, Texas recently, although skimming devices have been found attached to bank machines around Boston and Chicago as well.

The equipment used to capture an ATM card number and PIN was cleverly disguised to look like normal ATM equipment (see photos). A "skimmer" is mounted to the front of a normal ATM card slot that reads the ATM card number. At the same time, a wireless camera disguised to look like a leaflet holder is mounted in a position to view ATM PIN entries. The thieves then copy the cards and use the PIN numbers to withdraw thousands from accounts directly from the bank ATM.

One such known con using a similar M-O is Iljmija Frljuckic. It has been reported that Frljuckic stole at least 3.5 million, mostly from ATMs in New York City. Frljuckic accomplished this by purchasing his own ATM machines that are often found in



**1. Equipment being installed over existing bank card slot.**



**2. The equipment as it appears installed over the normal ATM bank slot.**



**3. The PIN reading camera being installed on the ATM is housed in an innocent looking leaflet enclosure.**

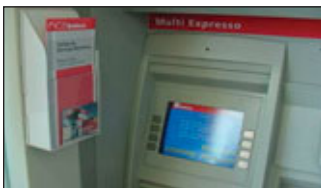

**4. The camera shown installed and ready to capture PINs by looking down on the keypad.**

convenience stores, gas stations, liquor stores, etc. He would then rig the unit with ATM card and PIN capturing devices, then installed the units in retail outlets.

The ATM fraud ring led by Frljuckic began in late 2001 with operations in California, Florida and New York. At 13 sites, Frljuckic installed machines rigged internally to capture bank data and personal identification numbers. Only after the gang began siphoning money did banks and customers realize they had been scammed. By the time the rigged machines had been identified, they had vanished, along with tens of thousands of dollars.

ATMs have always been a weak link in the banking chain. As a result, criminal activity has been heavily focused on them. If you ever see anything unusual around an ATM, it is recommended that you do not use the ATM and report it immediately to the bank, using the 800 number or phone on the front of the ATM.

One evening I drove into a bank to make a cash withdrawal from an island ATM. Next to the ATM was a drop box with a sign on it stating that they were sorry for the inconvenience, but the drop box was out of service. It then went on to ask that the drop be placed in the box provided. On the ground was a cardboard box, where people had actually put their bank bags. Go figure!

**Greg Mango**  
Editor



Allstate Insurance Company and Allstate Indemnity Company, Northbrook, Illinois. Allstate New Jersey Insurance Company, Bridgewater, New Jersey. Allstate County Mutual Insurance Company, Irving, Texas. Subject to availability and qualifications. ©2003 Allstate Insurance Company.



**Consolidate your business insurance with us and get more done with fewer phone calls.**

Your local Allstate agent can provide your business and employees with the protection they need, so you can spend less time talking about your business and more time running it. Call 1-800-859-0247 and see what the Good Hands® can do for you.

Circle 207 on Rapid Reply







# LETTERS

## Cross Country Now Requires Bonding

Cross Country Motor Club recently warned all locksmiths that you must be Bonded to act as a locksmith service provider. *The National Locksmith's* Bond qualifies. So if you are not currently Bonded by us, please contact us to order. The cost is only \$17 for a subscriber. 630-837-2044

## What a Joke

Give me a break! Your series on the installation of access control hardware by Richard Allen Dickey is a waste of good paper and ink. First of all, why was magnetic hardware chosen for this job? It's a single aluminum door! By using a magnetic lock, he has created several situations for the building's owner. First, now it is a fail-safe locking situation. If anything stops working the building is not secure. Second, if the electronics go bad there is no mechanical way to enter the door. Third, unless he is a certified fire installer, he has to hire a second party to interface with the fire suppression to release on smoke or fire. The better options would have been either a latch lock, egress paddle and electric strike, or even a panic bar with electric release.

If Richard Allen Dickey worked for my company he would be back flipping hamburgers. This appeared to be a clear aluminum door in good shape. After he finished cutting in the transfer

I would have made him purchase a new door for me. He took the time to measure and draw exact lines on the door, why didn't he use a saber saw and file and cut a clean hole rather than use dum-dum putty to cover his mistakes?

Then there is the choice of screws he used, black Phillips for the tabs and slotted screws for the transfer. We throw any slotted screws away as soon as we see them. I can't wait to see him install the electromagnet, he probably won't use any shim on the magnet so the armature does not make a complete contact (ie: the armature hangs below the magnet face).

*Name withheld out of embarrassment for the locksmith industry.  
Michigan*

**Editors Note:** I have so little respect for people who write letters like this, I can't even express it in words. It's not because he or she had something negative to say (I don't have a problem with that at all) it's because they do so and then cowardly withhold their name behind a veil of secrecy. Especially when the person they are attacking isn't hiding his name, or face.

Even if everything in this letter was correct—which it isn't—it is all negated by the fact that it was delivered in such a spineless way.

By the way, when was the last time you wrote a better article that was worthy of good paper and ink? I don't recall reading anything by you! Then again, how would I know, I don't know who you are.

For the record, my name is Greg Mango.

## Proof of Ownership

We received our April issue of *The National Locksmith* a couple of weeks ago. Marc's Commentary on checking the proof of ownership when unlocking cars and making keys was right on the money. Today my brother Steve, answered a call to provide keys for a 2003 Suzuki motorcycle. Upon his arrival at a private residence, something didn't feel right. He decided to make the keys while contemplating how to best handle this situation.

Because the owner couldn't produce the proper paperwork, Steve advised him to call when he had proof of ownership of the motorcycle and then the keys would be provided. A couple of hours later, as expected, the owner called to say he had the paperwork. What the owner didn't know was the Sheriff's Office was on standby for Steve to return

**Continued on page 10**



**E-mail Your Views:**  
[natlock@aol.com](mailto:natlock@aol.com)

Please include your first and last name.

## The National Locksmith

1533 Burgundy Parkway  
Streamwood, IL 60107  
Attn: Editor

The National Locksmith is interested in your views. We do reserve the right to edit for clarity and length.



Prices good thru Sept. 1, 2004

**STRATTEC ORIGINALS**

ref. H72-PT

**Best Price**

**\$4.95** No. 598333 Ford PATS II

**\$11.95** No. 599114 Ford PATS III

**\$6.95** No. HFPK3 Buick Original

**STRATTEC VATS SALE**  
VATS Sgl or Dbl \$4.95 ea.

**Cylinders**

**KARA**  
SC1 Kwy

**Mortise & Rim Cylinders**

**IL-7165SC \$4.95**  
1" bar stock mortise cylinder in Schlage C kwy. 26D, Dura, 60S

**IL-7015SC \$4.95**  
Schlage C rim cylinder 26D, 60S

**Thumbturn Cylinders**

**IL-7161TK \$5.45**  
1" solid bar stock mortise thumbturn cylinder. Choose 26D, Dura

**Dummy Cylinders**

**IL-7160DC \$3.50**  
1" solid bar stock dummy mortise cylinder. Choose 26D, Dura

**Knob / D'bolt Cyl.**

**IL-1599SC \$5.99**  
Fits Arrow D, E, F, K. Schlage B100,200,400 Operates most Grade 1 & 2 knob cylinder locksets. Screw cap retainer. \*Arrow TA,DD,BD use 1539

**Automotive**

**NEW A1 Originals - G.M Keying Kit, Ignitions & Key Blanks**

**A1 PINNING KIT GM H CARS**  
LeSabre / Bonneville Aurora / CTS

Ignition / Door / Rear Compt. Includes Ignition Retainers

P/N 20005 ORIGINAL EQUIPMENT

8722 Malibu Ign 2004

PK3 Large Bow with Buick or Pontiac Logo On-Board Programming

**A-1**

GMX 220 GMX 310

No.	Description	Price	Qty. Price
<b>KEYING KIT 20005</b>	Keying Kit, GM Late 'H' Cars Buick LeSabre, Bonneville, Aurora, CTS	33.95	
<b>7297</b>	Ignition unc. -Original Equipment, 2004 Grand Prix	23.95	
<b>IGNITIONS 8328</b>	Ignition unc. -Original Equipment, LeSabre '00+, CTS 00-03 (auto)	16.95	
<b>8492</b>	Ignition unc. -Original Equipment, Bonneville, Aurora 2000+	33.95	
<b>8722</b>	Ignition unc. -Original Equipment, Chevy Malibu, 2004+	23.95	
<b>KEY BLANKS GMT265</b>	Xpndr Key -Orig Equip f/On-Board Prog, 2004 Caddy SRX	18.89	... 5@ 18.29 ea
<b>GMX220</b>	Xpndr Key -Orig Equip f/On-Board Prog, LeSabre/Aztec '00+	12.99	... 5@ 12.49 ea
<b>GMX310</b>	Xpndr Key -Orig Equip f/On-Board Prog, Bonneville/Rendezvous '00+	12.99	... 5@ 12.49 ea
<b>GMX320</b>	Xpndr Key -Orig Equip f/On-Board Prog, Cadillac CTS 2003-04	18.89	... 5@ 18.29 ea
<b>GMX367</b>	Xpndr Key -Orig Equip f/On-Board Prog, Grand Prix 2004	14.89	... 5@ 14.29 ea
<b>GMX380</b>	Xpndr Key -Orig Equip f/On-Board Prog, Chevy Malibu 2004	14.89	... 5@ 14.29 ea

**Simplex**

5000 6200

L1000 L1021

7000

**2 Models**

**\$16.95**

**Master Lock Key Storage**

No. 5400 Shackle Mount  
No. 5401 Wall Mount

4 dial resettable combination. Body & shackle are coated to prevent scratches. Cast body is reinforced to withstand attack.

**No. DL2700-26D In Stock**

Cylinder key override standard. (SC1). Non-handed, assures versatility & ease of retrofit. 2-3/4" backset. For 1-5/8" to 1-7/8" doors. Uses 5 AA batteries.

**American Solid Steel**

No. 700KD \$14.60  
No. 700KA \$15.10

**American 2000 Round**

No. 2000KD \$14.55  
No. 2000KA \$15.05

**PRO Series Std Shackle**

No. 6121KD \$10.49  
No. 6121KA \$10.99

**PRO Series Long Shackle**

No. 6121LJKD \$11.69  
No. 6121LJKA \$12.09

**Machinery**

**Sale**

**IL-045 110v \$419.00**

The 045 cylinder key duplicator cuts a wide variety of cylinder keys. It has 4-way vises, wide jaw spacing & a deburring brush.

Made in U.S.A. 110v

**Rytan**

**RT-RY100 \$789.00**

Lever operated semi-auto cylinder key duplicator. Large 3" milling cutter. 2-way machinist type vises. Accuracy, durability and blazing duplication of cylinder keys.

**PL-Blue Punch \$745.00**

The Blue Punch is a fast, extremely accurate, dedicated machine. Fast and easy to use. Best I-Core & Schlage SC1 models

**240B**

144 pc refill packs 99¢

Choose 003 or 005 Pin Kit

**.003 or .005 Increment COLOR Pin Kit \$93.95**

No. SPK33 .003 Increment Kit 124 sizes .003 increment. Bottom pins .156 to .360B Top pins .010 thru .200T plus springs.

No. SPK55 .005 Increment Kit 113 sizes .005 increment. Bottom pins .115 to .360B Top pins .010 thru .320T plus springs.

**Popular Strattec Ignitions**

No.	Description	Price	Qty. Price
<b>700754</b>	Ignition w/slave GM, Popular VATS 1986-02	26.95	3@ 24.95 ea
<b>702671</b>	Ignition unc. GM, Popular CSS 1995-97	17.95	3@ 15.95 ea
<b>703225</b>	Ignition unc. GM, CSS MRD '96 Cavi/Sunfire	62.95	3@ 58.95 ea
<b>703602</b>	Ignition unc. GM, MRD In-Dash 1997-04	56.95	3@ 52.95 ea
<b>703719</b>	Ignition unc. Chrysler, Modular w/SB 1998-04	13.95	5@ 12.95 ea
<b>707624</b>	Ignition unc. Ford, 8 cut w/o SB. 1996-04	14.95	5@ 12.95 ea

**THE LOCKSMITH STORE**

**RCI 6 Series "All-in-One" Strike**

Fail locked or Fail unlocked - You choose in the field. Simply turn the screw on the back 180 degrees and "voila!"

All-in-one multi-voltage coil. Select the appropriate female connector and you're done. 12/24 VAC/VDC - You choose!

Up to 1/4" Horizontal adjustability for proper alignment.

Order# S6514-32D - **\$73.40**





## Letters

### Continued from page 8

to the scene, copy the VIN from the motorcycle on the invoice, collect his fee for the keys and relay the VIN to the Sheriff. Within minutes, two stolen motorcycles were recovered and our local detention center had two new guests.

We have always tried to do what was reasonable and prudent when providing locksmith services to the public. In this case an ounce of caution was worth a pound of prevention.

*Tim Medlock  
South Carolina*

### Still Lots to Learn

I am the pilot of an EMS Helicopter for my full time job and do locksmithing in my off time, which is rather new to me.

First real-live service call for Dan today. No problem! Reprogram a 1994 Lincoln Continental remote. Customer is my barber, son needed a haircut anyway.

Got the info to reprogram the remote, piece of cake. Turn key on, drop glove box, short two pins on plug, press lock button on remote, shouldn't take more than a few minutes, right?

Ron's Barber shop faces Main St. and he parks right in front of his window. It's Saturday morning and the place is packed. Bored customers watch locksmith attack passenger side of car.

Wow, this is a nice car! Whoops, glove box is full of junk. Spend about five minutes stacking six years of "stuff" neatly on floor. Spend another two picking overflow out of dash by all the wiring harnesses. Barber's customers taking turns walking out to eyeball me.

Found the plug, got my copper wire, no sweat. Shorted pins, car door locks cycle just like they should, but the remote won't make the car respond. Customers begin to chuckle as I start troubleshooting. The locks cycle so the battery in remote must be dead. Barber says it's about four years old. Twenty minutes and a trip to Wal-Mart later, I'm ready to go again.

Turn on key, short plug... nothing. Try to start car, deader than Pee Wee Herman's career. Is it too late to go back to my real job?

My 10-year old is now in the barber's chair. I ask Ron if he has jumper cables, customers begin belly laughing. Ron's eyebrows shoot up towards the top of his head and my son is now going from trim to high-and-tight.

"Sure," Ron says, "The cables are in the trunk." I ask about the trunk key, he says he doesn't have one, was going to ask me to make him one. Battery is so dead keypad doesn't even work. Sweating begins and most of the customers are now in tears. Not sure I want to be a locksmith today.

Twenty minutes later, enough juice to pop trunk. Grab cables, his battery is waaay dead. I'm on phone with Ford Rep, who tries to tell me there is no way to harm the electrical system by jumping that plug.

Ron gives me \$60 and I'm off to Auto Zone to buy battery for customer. I just want to be a helicopter pilot again, let me go back to flying in the dark up in the Sierras, that's easy.

One hour later, customer has new battery. I have an audience who applauds my first successful part of this job. Ford rep tells me serial number of Ron's remote is for another Ford, not a Continental. Considering putting tools on Ebay tonight.

My son now looks like a Marine recruit and none of Ron's customers can stand now from laughing cramps. I realized that I can blush to the shade of a tomato and the darn remote still doesn't work. I clean up and Ron actually says, "What do I owe you?"

I told him, just kick me in the head and we'll call it even. He says, no, gives me my son's haircut on the house and lets me have the core deposit from the battery.

All in all, not counting the three hours of humiliation I netted \$3 more than I was going to charge him in the first place. As my bald-headed son and I drive home I think to myself, whew, this isn't so bad...but I can't wait to get to my regular job.

Anyone need a remote for a Taurus?

*Dan Beauchamp  
California*

### No Checks

I just read the letter from Willie Bowen about refusing to accept checks. Have you noticed that in many restaurants there is a sign that refuses to accept checks? The debtors are almost never prosecuted.

Mr. Bowen did not elaborate about the warrant in debt, but for 30 years I was a locksmith in Los Angeles and Orange County, CA. "Warrant in debt" is not handled in small claims court. It would have to be a Municipal court or higher. If you could do this yourself, what would your cost be in time? What would the cost be for an attorney to do it?

Would Mr. Bowen please take us through this step-by-step and share with us his experience in collecting debts this way and the success rate? What was the average time to collect? What length of time did the debtor serve in prison if any? What state or county was this in?

*Richard Ingeman  
Arizona*

### Now That's Low Tech

I've gone through many of your magazines trying to find a listing for Low Tech Products (based out of Oregon) to no avail. Any help in getting a fax or phone number for them would be greatly appreciated.

*Dwight, Edmonton  
Alberta, Canada*

**Editors Note:** We have been unable to locate or contact Low Tech Products. Don't know if it is still in business.





EXTRA! EXTRA! READ ALL ABOUT IT

Adams Rite  
is giving away

**COLD HARD CASH**



THE ADAMS RITE  
**REGISTER**

Adams Rite  
Introduces  
New Product  
Line-up

MS Maglock  
Latch Pull  
E-Trim  
MS1950 Deadbolt

Purchase and  
Install Before  
Dec. 31, 2004

**\$50-\$500**

Check out this  
sweet deal.

## Install The MS<sup>®</sup> Maglock And Get Paid!

We're so confident that you will be amazed by the MS<sup>®</sup> Maglock that if purchased and installed before December 31, 2004, you will receive a randomly selected VISA Gift Card worth anywhere from \$50.00 to \$500.00!

The Gift Card can be used anywhere that accepts VISA debit cards. The MS Maglock is less than 2" x 6", but features an amazing 4,000 pounds of holding force. This means it will fit almost anywhere while providing maximum security, and installation is a piece of cake.

The MS Maglock VISA Gift Card will be all yours to spend how you like. For offer terms and conditions, log on to our website or call (800) 872-3267 for a brochure.



**ADAMS RITE**  
MANUFACTURING CO.

[www.adamsrite.com/promo1](http://www.adamsrite.com/promo1)



# SSALOA SHOW STOPPERS

This years ALOA convention is in Baltimore, MD and there is sure to be lots to see. Several new products are being introduced this year, and your best chance to see them first hand and in person is at this show.

## Door Hardware

### **Arrow Pointe Interchangeable Core**

Arrow's Pointe Interchangeable Core offers dealers unmatched flexibility and keying options. The unique manufacturing process in the Arrow Pointe IC Core features four main components: the plug, shell, locking sleeve, and faceplate. This precision process allows for a



stronger core. The Pointe is a standard format IC core and is available in 6- 7-pin, Arrow and competitive keyways.

Arrow Keyways: 1C, 1D (standard) & Restricted Keyways (consult factory for availability) Best Keyways: AB, BB, CB, DB, EB, FB, GB, HB, JB, KB, LB, MB, & QB. 6-Pin: 100CR x keyway; 7-Pin: 7100CR x keyway; 26D & US4 Finishes; Combined and Uncombined; Sleeve Design and Solid Brass Construction.

### **Kwikset Universal 6-Way Steel Latch**

Kwikset has introduced the 6-way steel latch on its complete line of entryway, privacy and passage knobs, levers and handlesets for all Kwikset UltraMax Security, Kwikset Maximum Security and Kwikset Security products.

The ANSI Grade 2 latch, one-piece drive-in collar and chassis feature all steel construction. Works with a Kwikset strike and

are packaged in the finish of the corresponding hardware to ensure that the completed doorway has a consistent look. The Kwikset 6-way steel latch passes the rigorous strength test by BHMA to reach the ANSI Grade 2 certification. The latch is facto-





ry tested to survive more than 400,000 cycles and comes with the standard finish warranty provided on all Kwikset locksets.

### **Pannex by Door Controls International**

Door Controls International, the US manufacturer of Pannex™, has a certified Grade 1 security rim exit device. The patented interlocking latch and strike is virtually impossible to tamper with, pry, or force open, and will resist 2000 lbs of applied force without unlocking the door. In addition to providing maximum security, the Pannex™ Series is versatile for all types of applications including narrow-stile aluminum doors. All devices are weather resistant, and are offered with electric lock/unlock, three different alarm modules, and is available fire rated.



Even though Pannex™ is certified to the highest industry standards, and provides superior protection while fulfilling life safety requirements, the devices are competitively priced and are available in 3 to 5 days from the factory. Pannex™ is the ideal solution on high traffic doors where security and safe egress are your major concern.

### **The Eagle by GU Hardware**

From G-U's New Breed of Security line, the "Eagle"



Automatic Latch system automatically and independently engages at each latch with a G-U patented design. No lever lifting is required to engage locking points; Multi-point latches become deadbolts when door is closed. The entire system is easily locked and unlocked by turning thumb turn 90-degrees inside, or with key outside.

Increased security with multiple locking and 1" deadbolts and weather tightness in all of G-U's New Breed, are insured in their state-of-the-art products with key-in-knob cylinder for easy re-keying, Schlage "C" keyways, a typical U.S. design with deadbolt above latch, and precision manufacturing that makes all G-U products superior.

### **MARKS USA Grade 1 Tubular Deadlatch**

Marks USA has now developed an ANSI grade one tubular deadlatch. This product was created by modifying its grade one tubular deadbolt components to accommodate a new heavy duty, grade one tubular latchbolt. The



latchbolt features a stainless steel deadlocking latch nose with a 9/16" latch throw. The result is an easy to install tubular deadlatch, which is available in both conventional as well as IC core cylinder models.

### **Adams Rite 4593 Latch Pull**

The Adams Rite 4593 Latch Pull™ is a lockable pull handle that offers flexibility of traffic control during and after business hours. It is suitable for all applications, which require free entrance at certain times and controlled, or exit only access at other times. It offers one-handed operation and two modes, which can result in the locking of the door upon closure, or just latching the door to allow easy access.



Its classic looks, heavy duty construction, and flexibility has allowed the Latch Pull, along with a deadlatch for metal stile glass doors, to blend in with any architecture and become a popular replacement for a traditional deadbolt in narrow, medium and wide stile aluminum doors. Retrofitting with the Latch Pull is a fast and simple operation that requires a minimum of tools. All necessary mounting hardware is included with the device as well as preparation

**Continued on page 16**





LOOK INTO LOCKMASTERS,

IT WOULDN'T BE THE ALOA CONV

800.654.0637    [lockmasters.com](http://lockmasters.com)    [techtrainprod](http://techtrainprod)



**LOCKMASTERS**®

**IF YOU HAVEN'T ALREADY.**

**ATTENTION WITHOUT LOCKMASTERS.**

[lockmasters.com](http://lockmasters.com)   [pureauto.com](http://pureauto.com)   [lsi-lockmasters.com](http://lsi-lockmasters.com)

Circle 247 on Rapid Reply



templates for both right handed and left handed operation.

The Latch Pull is available in 3 painted finishes, has an electrification option either pre-installed or in kit form and is ADA compliant. The device is adaptable to use with either 5-pin, 6-pin or 7-pin lock cylinders, and works with Adams Rite 4500, 4700 latches and 8300 & 8400 series exit devices.

**Yale 8800 Mortise Lock**

The new Yale 8800 Series of Grade 1 mortise locks combine the dependable quality of the Yale brand with features and functions never available before on a Yale mortise lock.

The 8800 features a Quick Reversible Latchbolt that allows the handing to be changed in seconds. To reverse the handing, simply press the latchbolt retaining plate, pull out the latchbolt and rotate 180 degrees to the desired handing position. The 8800 also comes with a standard non-handed curved lip strike, which eases the operation of the latchbolt, ensuring positive latching. The non-handed strike also simplifies the ordering process.



The 1" throw stainless steel deadbolt in the new 8800 Series extends further back into the case when in the locked position, providing added stability and resistance to abuse. The 8800 fits the same door prep at the 8700 Series mortise lock, so retrofits

are simple. All trims available for the 8700 will also fit the new 8800. In addition to those functions currently offered on the 8700 Series mortise lock, the 8800 Series adds nine new functions, including the Double Cylinder Intruder Classroom Security Lock.

**SELECT Hinges**

Doors with butt or pivot hinges can sag and bow, causing locks to fail. SELECT full, and half-surface continuous gear hinges salvage doors and frames and solve door problems, helping facility managers avoid maintenance costs and headaches for life. Independent lab tests on an FRP door confirm that SELECT Hinges™ will perform well over 10,000,000 cycles, more than some building entrances see in a lifetime.



SELECT Hinges™ are guaranteed for the life of the entrance because exclusive Pair-Matched™ components and lifetime lubricants assure years of trouble-free hinge performance. And SELECT provides the industry's fastest delivery time.

**Frontier Double Bar Lock**

The Frontier Double Bar Lock is a vandalproof locking device designed for in and out swinging doors. The lock, which is mount-

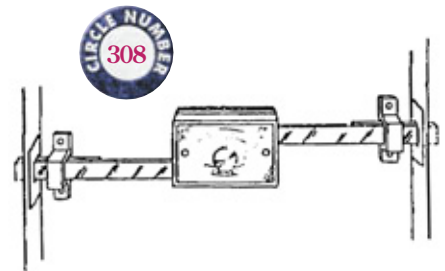

ed in the center of the door, drives two horizontal bars in opposite directions into the door frame. The bars are moved by a keyed entry on the outside and a thumbturn knob on the inside. The tailpiece of the keyway passes through a gear drive, which moves teeth on the bars inside the lock housing. The outside is protected by a vandal proof plate which installs over the cylinder.

**Baldwin's UL Listed Mortise Locks**

Baldwin Hardware Corporation has not only successfully passed the UL Listing test criteria for its mortise locks, but has achieved a 3-hour rating, the highest possible for residential locks. Now architects and builders can confidently specify both UL Listed locks and trims in architecturally correct styles and fashion finishes from a single, trusted source. With the introduction of Baldwin's new UL Listed locks and trims, it is no longer necessary to mix hardware from one supplier with a mortise lock from another. Their new UL Listing covers all







# POWER UP.

**E-PLEX™** Built on more than 40 years of pushbutton lock experience, the new E-Plex 5000 is strong, durable and reliable – combining ease of use with the added security of electronic access control. The E-Plex 5000 accepts 100 access codes and records 3,000 audit events, including key override usage. The lock is easy to install and does not require wiring through the door. Locks are quickly programmed with the lock's pushbuttons or managed with optional Microsoft® Excel based software as your user group grows. Contact Kaba today to find out how powering up with E-Plex can put you in command of access control.

- **PROVEN SIMPLEX® MECHANICAL RELIABILITY**
- **EASY TO INSTALL**
- **EASY TO MANAGE**
- **MULTIPLE ACCESS CODES**
- **AUDIT CAPABILITY**

1-800-849-8324  
www.e-plexlock.com

**KABA**  
TOTAL ACCESS

Circle 236 on Rapid Reply



Baldwin Estate mortise entry and Estate passage and privacy hardware, roses, cylinder collars and turnpieces with backplates in any one of their rich spectrum of stylish finishes.

Baldwin's UL Listed mortise locks will provide architects and specifiers with the ideal decorative hardware solutions to three major challenges: expressing the owners decorative vision, maintaining the customers sense of personal style, and meeting the building inspectors code requirements.

**S Parker Hardware Series 441BC Door Closer**

Building owners and facility managers as well as architects of office buildings, retail stores commercial buildings and schools can now install ADA Compliant, size 1 through 6, power adjustable door closers in their buildings. Newly available

duty arm and heavy-duty stop arm with hold open.

Featuring adjustable sweep and latch speeds with separate valves to adjust each speed, this door closer can be installed with regular arm (120° door opening) parallel arm (180° door opening) or top jamb (120° door opening). The S. Parker Series 441BC can be installed on either side of the door and can be ordered with an adjustable delayed action closing. It comes complete with a high impact molded plastic, full cover as well as a peel-and-stick template to facilitate installation.

**Security Products Inc. Door Package**

Security Products Inc. unleashed its new line of extreme duty complete door packages. It comes completely pre-assembled. The door arrives ready for installation, saving hours on the job site.

Boasting specifications like fully reinforced galvanized steel construction, a 14 gauge fully welded face and throat frame, 16 gauge fully reinforced door, one continuous door hinge rated at 1.5 million cycles, a 25 year warranty, ANSI grade 1 door closure,



from S. Parker Hardware, this UL listed door closer is in compliance with ANSI A156.4 Grade 1. It also conforms to the Americans With Disabilities Act and ANSI A117.1 specifications for making buildings and facilities accessible to and usable by the physically disabled. Specified as Series 441BC, this multi-size full feature door closer is constructed of cast iron. It is manufactured under ISO 9002 guidelines and is available in a choice of arm types including heavy-



24" high stainless steel interior and exterior kick plates. These doors also come standard with the ultra high security exit hardware combination of the Monitor 4000 door alarm and the MP5 Police 4 point locking panic bar. The doors can be ordered with several different options of powder coat or urethane finishes.

**Safes & Safe Products**

**Perma Vault Pistol Box**

Designed for easy carrying or bolting in the trunk of a car, Perma-Vault's Model PV-1-PL Pistol Box provides firearm security while still allowing easy push-button lock access for the owner. Ideal for use in the home or by law enforcement agencies, the U.S. made, 14-gauge steel, 11-pound pistol box has a comfortable suitcase style and is secured with an Illinois Lock push-button lock.



The pistol box is lined with heavy duty felt on the bottom and sides and thick egg crate foam on the top. The pistol box measures 4-1/2" high by 12" wide by 10" deep.

**Phoenix Safe Data Commander Safes**

Phoenix Safe International, LLC now offers 3 new large data safes. The Data Commanders range from 4.59 - 15.75 cu. ft. capacity. The safes carry the SP Class 125-2 hr. fire rating, a 2-year parts & labor warranty, and a lifetime free-after-a-fire replacement guarantee.





The safes are equipped with an easy to use EDL electronic lock, and also include standard accessories of multi-media drawers and adjustable shelves.

The Data Commanders are in stock for quick ship purposes, and ship within 48 hours. Like all Phoenix products, freight is included in the pricing for shipment anywhere within the 48 contiguous US states, and Phoenix's minimum order is 1 product.

**LA GARD Introduces New LGBASICII**

LA GARD, Inc., has released an upgrade to its popular LGBA-

SIC electronic locking system, designated the LGBASICII. The new LGBASICII has been redesigned to provide original equipment manufacturers and authorized resellers a simpler, more flexible installation. The LGBASICII keypad design melds the angular design of the current LGBASIC keypad with the snap-on style of LA GARD's popular SAFEGARD product. LA GARD offers a choice of finishes including satin chrome, bright chrome, polished brass or black, and a battery compartment located under the keypad.

Used with LA GARD's high security Dual-Handed Swingbolt lock, which is equipped with a non-volatile memory, the LGBASICII will not lose its code if the battery is disconnected or suffers a power loss. The lock is powered by a 9-volt alkaline battery and includes an audible and visual signal when the battery is running low. Another feature in the LGBASICII is the "wrong try penalty." This feature engages when a person enters an invalid code four consecutive times. It will activate a "time penalty" and disallow the user to operate the lock until the penalty period has expired.

Flexibility is the hallmark of LA GARD's product line and for that reason the LGBASICII can be used with either the 3765-2 or the 3260 Dual-Handed Swingbolt Lock.

**Mutual Safe Company's New Gun Safe**

Mutual Safe Company, Inc. of Costa Mesa, California is proud to introduce it's newest range of gun safes; the newly redesigned MK range. The MK gun safe offers magnificent protection against both fire and burglary. The safes are constructed of 1/4" steel in the door and back and 1/8" steel in the rest of the body. The locking mechanism is protected by a state of the art relocker. Five 1" locking bolts are standard in all models to protect your vital contents.



The safe is protected from fire by a sheetrock-like fire retardant material recommended by UL. The interior is beautifully carpeted and comes with either four adjustable shelves or a combination of gun racking and adjustable shelves. An optional electronic upgrade is available



 <p><b>HL Flake Company</b> Houston Texas 800-231-4105 888-329-0601fax</p>	Row 200 400 600 800 1000 1200	 <p>Entrance</p> <p>ALOA Booth</p> <p>HLF</p> <p>COME SEE US!</p>	<p>HL Flake Booth #1256</p> <p><b>A Full Line Distributor</b> 19,000 items</p> <p>July 23-25 2004</p>
	<p><b>ALO A Show 2004</b></p> <p><b>Support ALOA... Join Today!</b></p> <p><b>See you in Baltimore!</b></p>		

from the standard combination lock. There are three models available that consist of three different sizes.

### **New X-0 Troubleshooter CD**

MBA USA has developed a simple method of troubleshooting the entire series of X-0 electronic safe locks. Their new interactive CD is loaded with great advice, color photos, and live video clips that will help you get your problem locks open fast. Simply select the lock you are



having problems with and the troubleshooter leads you step-by-step, analyzing the problem and suggesting probable solutions. Bad LCD's, stubborn stepper motors and dozens of other issues are dealt with in a clear logical manner.



### **CSS To Unveil Modular Self-Checkout Solution**

Corporate Safe Specialist's new modular self-checkout solution called SOS, goes beyond traditional benefits of self-checkout by adding their own unique features like the JCM recycler. This allows it to recycle cash, making it a single payment and collection device at a single point on the kiosk. It also is the first dual use cashier kiosk system on the market. A "safe inside" cash handling feature makes SOS both customer friendly and cash management secure.

The system not only saves the customer time, but by connect-

ing to a wide variety of existing front and back office solutions, SOS can also automatically send shift or end-of-day reports to existing databases. Connecting to existing POS, CCTV and Smart Safe systems, makes it a tool in cash management both onsite or off and open architecture means the retailer can grow with technology by adding new software and devices.

### **ADESCO Deposit Safes**

The newest editions to Adesco's business line take advantage of the latest technologies available. This series offers small business with an excellent storage solution at an affordable price. These safes include their VisionGard spy proof dial and a lock that is UL tested to resist surreptitious entry.



Doorjambes are reinforced and tied to the body of the safe with solid blocks of steel, creating steel-to-steel resistance against a sledgehammer attack. The RD models feature a large 9.75 x 3.75 x 6 package size and the PD series offers a max package size of 3 x 11 x 8.

### **New StrongArm MiniRig Uni-Temp**

The Universal Template attaches to the safe's dial ring mounting screw holes for safe drilling with the MiniRig. Uni-Temp uses an X-Y axis system, built-in scales and an index to allow you to set specific up, down, right and left measurements from the spindle hole center.



Set-up is very fast. Lock in your setting, attach the MiniRig and start drilling. The MiniRig quickly removes from the Uni-Temp for bit changes and hole inspections without re-adjusting. An additional mounting provision allows Uni-Temp to be mounted anywhere on a safe or vault, not just the dial ring screw holes. You can now use your favorite drill points on all types of locks with the MiniRig and Uni-Temp. In addition you can use it with a lever bar rig or magnetic drill press for accurate positioning and drill points.

### **Cash-Link Coin Vending Safe**

Cash-Link manufactures a complete electronic update kit, designed with the latest components, and technology, which will allow the professional Locksmith to convert any existing TACC II thru TACC II R Coin Vending Safes, into a more reliable product with 67% fewer parts.

The kit includes, a new Touch panel, new Main Board, new





Lower Sensor Board, new Low Voltage Wall Transformer, and all wiring harnesses required. Cash - Link also carries a full line of Supplies, New, Tested, and used parts for the TACC II.

## Miscellaneous Products

### Medeco's New Padlock Line

Medeco High Security Locks is introducing a new line of padlocks. The new Medeco High Security Padlocks are compatible with all Medeco technologies and cylinders, including Original, Biaxial, Medeco3 and KeyMark, as well as small and large format interchangeable cores. Available September 1, the new line replaces and simplifies Medeco's previous padlock line with basic padlock body styles that can be ordered to accept a variety of cylinder types for keying into door hardware systems.



The black chrome, hockey-puck style padlock, offering attack resistance in excess of 1200Lbs. of force, is the first padlock from the new line and available now. The new padlocks are covered by a two-year limited warranty and are available through Medeco and authorized Medeco distributors.

### Trailer Lock from American Lock Company

American Lock Company has developed the Defender, a heavy-duty, high security trailer locking device, which can lock down a semi trailer and help

prevent its theft when the trailer is not hitched to the tractor. The device's best application is for loaded trailers which need to be parked outside of a protected marshalling yard or truck terminal.

The locking device is a metal cap, which fits over the trailer's crank handle. A notch on the unit fits directly over the crank handle. Once the Defender is placed over the handle, a Model 784 American Lock padlock can

be placed through receiving holes on the back side of the cap. After making sure the shackle is behind the crank



Continued on page 24



two  
for the  
price of  
one

Dual reading technology / active and passive

PROXIMITY CARD READERS

A unique feature of the DKS proximity card reader product line is that the card readers are compatible with both passive and active tags. This allows a mixing of different cards and tags to achieve desired read ranges in different locations without having to install a second card reader or carry two tags. These readers feature a cosmetically appealing design that will blend in with any architectural design and offer high durability and reliability



Telephone Entry Systems

RF Transmitters

Parking Control

Gate Operators



**DoorKing<sup>®</sup>, Inc.**  
120 Glasgow Avenue, Inglewood, California 90301 U.S.A.  
Tel: 310-645-0023 1-800-826-7493 FAX: 310-641-1586  
E-mail: info@doorking.com www.doorking.com



Through Innovation, Quality Control, and our insatiable drive to improve, PRO-LOK locksmith tools have become the industry standard for excellence. All our our picks are manufactured from the finest full hard spring stainless steel, making them the strongest, most durable picks available - with the added advantage of being rustproof. Other companies utilize riveted construction to attach their handles - a method in which rough surfaces are inherent. We developed a better way. Our exclusive rivetless construction leaves the stainless steel handles smooth from end to end, making PRO-LOK picks both beautiful and comfortable to use. Each set of our premium quality tools comes to you in a soft, luggage quality, top grade leather case, providing secure, handsome storage. Compare - and like so many others, you'll discover the PRO-LOK advantage. Thank you for choosing PRO-LOK.



Comfortable, smooth rivetless construction

Rust proof, Full hard spring stainless steel

## Superior Quality, Construction & Materials

## Tempered Stainless Steel

## Rust Proof Picks











## Smooth Rivetless Construction

## Full Hard Spring Stainless Steel











## Deuburred & Burnished to Soft Luster Finish

## The Strongest & Most Durable Picks Available!

### Picks with Handles

-  PKX-DB-H Double Ball-Handle
-  PKX-DM-H Double Mountain-Handle
-  PKX-HDL-H 1/2 diamond large-Handle
-  PKX-HDS-H 1/2 diamond small-Handle
-  PKX-KE-H Key Extractor-Handle
-  PKX-LC-H Large Comb-Handle
-  PKX-LH-H Large Hook-Handle
-  PKX-MH-H Medium Hook-Handle
-  PKX-SB-H Single Ball-Handle
-  PKX-SC-H Small Comb-Handle
-  PKX-TR-H Traditional Rake-Handle

### Picks without Handles

-  PKX-DB-P Double Ball-Plain
-  PKX-DM-P Double Mountain-Plain
-  PKX-HDL-P 1/2 diamond large-Plain
-  PKX-HDS-P 1/2 diamond small-Plain
-  PKX-KE-P Key Extractor-Plain
-  PKX-LC-P Large Comb-Plain
-  PKX-LH-P Large Hook-Plain
-  PKX-MH-P Medium Hook-Plain
-  PKX-SB-P Single Ball-Plain
-  PKX-SC-P Small Comb-Plain
-  PKX-TR-P Traditional Rake-Plain

### Misc. Picks & Tension Wrenches

-  PKX-TW-F Tension Wrench-Forked
-  PKX-TW-L Tension Wrench-Light
-  PKX-TW-M Tension Wrench-Medium
-  PKX-TW-R Tension Wrench-Rigid
-  PKX-TW-TL Tension Wrench-Long Twist
-  PKX-TW-TS Tension Wrench-Short Twist
-  PKX-DR-C Combo Diamond/Rake
-  PKX-HR-C Combo Hook/Rake

# PRO-LOK

655 N Hariton Street Orange, CA 92868 • (714) 633-0681 • Fax: (714) 633-0470



# STAINLESS STEEL PREMIUM PICKS & SETS

## PKX-11 11 picks & case

This popular set includes 3 picks with stainless steel handles, 3 standard picks, a double ended slim line pick, broken key extractor and 3 tension wrenches in soft luggage quality leather snap case.



## PKX-14 14 picks & case

Our most popular pick set comes with 9 picks and a broken key extractor, all manufactured of tempered stainless steel and all with rivetless stainless steel handles, 4 tension wrenches in a soft luggage quality leather snap case.



## PKX-20 20 picks & case

This set contains 14 assorted picks (6 with rivetless stainless steel handles), a broken key extractor and 5 tension wrenches in a soft luggage quality zipper leather case.



## PKX-32 32 picks & case

This large set includes a variety of tempered stainless steel hooks, rakes, balls, diamonds, key extractors, and tension wrenches in a soft luggage quality zippered leather case.



## PKX-62 62 picks & case

Open the quality zippered leather case and you'll find the finest lock picks made. The PKX-62 includes an array of hooks, diamonds, balls, rakes and broken key extractors manufactured of tempered stainless steel and features our rivetless stainless steel handles that provide maximum picking comfort, six tension wrenches, and our PKX-WP5 warded pick set.

Dedicated to  
**Chloe Jade**  
May 2, 2004

[www.pro-lok.com](http://www.pro-lok.com)

Circle 266 on Rapid Reply



shaft, the padlock can be closed and locked, securing the shackle from intrusion.

Locks such as the Model 784 can be keyed alike for multiple application across a trucking fleet, or can be masterkeyed to allow access to only certain operators. The Model 784 is created from a solid bar of case hardened steel and a cylinder milled from solid brass with either a 5- or 6-pin tumbler.

### **D&D Lokk-Latch Round-Post for Chain Link**

D&D Technologies has a new model of the company's popular Lokk-Latch®. The Lokk-Latch Round Post, model LL5ARND, fits chain link and other round posts with diameters ranging from 1-7/8" to 2-7/8", and gate frames ranging from 1-3/8" to 2". The latch is key-lockable, fits up to 2" gate gaps, and has an optional push-button External Access Kit. D&D also introduces the Tru-Close® self-closing Round Post Hinge for heavy-duty gates.



Ideal for larger gates up to 132 lb., the TCHDRND1 model fits post diameters of 1 7/8", 2", 2-3/8" and 2-7/8", and gate frames of 1-3/8" and 1-5/8". The TCHDRND2 fits fence post and gate frames 1-7/8" to 2". Like other D&D gate hardware products, these new products are made of molded, glass-reinforced polymers, so will not rust, and come with a Limited Lifetime Warranty.

### **Tiger Line Introduces Two Trailers**

Tiger Line announced the Tiltster and the Trailevator.



These two trailers are capable of hauling many heavy loads and will save you the expense of buying a second truck for hauling. The Tiltster features a low bed trailer that tilts and it's available in capacities ranging from 3000 to 7000 pounds.

The Trailevator is a hydraulically operated, elevating trailer which not only lowers itself to ground level for easy loading; it also lifts its own weight as well as the load back to the hauling position.

### **Medeco's FileSecure**

Medeco announces the addition of the FileSecure file cabinet locking bars to their product line. FileSecure bars are ideal for storing sensitive material and preventing unauthorized access. A slight upward motion of the inner slide bar releases all locking points allowing the spring loaded bar to gently swing out of the way. The compact design of FileSecure gives sufficient clearance for unrestricted access to adjacent file drawers.



FileSecure bars are available in various sizes to fit anywhere from one to five drawer cabinets.

All bars are constructed of 16 gauge formed steel using a durable powder-coat acrylic enamel finish. FileSecure bars are available in a combination Medeco Black/Grey or Chrome/Orange. The inner slide bar interlocks with a locking lug at each drawer opening when in the locked position providing added security. FileSecure bars can be combined with Medeco padlocks to add an extra layer of security and key control to the physical protection provided by the FileSecure bar.

## **Automotive Products**

### **Lockmasters Keyless Remotes Packages**

Lockmasters' new Keyless Remote Packages are make, model, and year specific and are specifically designed to cover a wide array of applications for a very minimal investment. Packages feature new, replacement remotes, application guides and complete programming instructions for all applications in the package.

For as little as \$100, the locksmith can now purchase a remote package that covers dozens of the most popular vehicles on the road today. A variety of packages are available covering Ford, GM, Honda and





Mitsubishi and programming instructions are thorough and easy to understand.

**Bianchi TD-3000  
Transponder Detector**

Bianchi USA has recently introduced the TD-3000 transponder detector. The TD-3000 enables automotive specialists to cut late model keys with confidence. A simple push of the button and the advanced technology will detect the presence of a transponder. The digital display will show the text results.



The TD-3000 identifies the most complete range of automotive transponders in use today including both fixed and encrypted versions of Texas Instruments, Megamos, Philips, and Temic. The innovative, compact, and light design make this easy to use tool a must due to the high saturation of transponder equipped vehicles in the marketplace today.

**KeylessRide Unveils  
New Products**



KeylessRide announced the immediate availability of two new Keyless Entry Service Packs to the locksmith industry. Their new keyless entry service packs, used in conjunction with Vetrionix Corporation's Tech2 and ASP's T-Code scan tools, allow locksmiths to offer a much



**Your best answer!**

**Question:**  
**What is  
Securadealer.com?**



**Answer:**  
**A free web site for  
Locksmiths in the U.S.  
and Canada.**

**Visit SDI in booth #433 at ALOA.  
See if you qualify and if you do,  
register for a chance.**

**Hans Johnsen Company**  
Dallas, TX  
Phone: (214) 879-1500  
Toll Free: 1-888-879-1500  
FAX: 1-800-967-4250

**K-D-L Hardware Supply, Inc.**  
Seattle, WA  
Phone: (206) 682-7383  
Toll Free: 1-800-926-7716  
FAX: 1-800-524-9305

**Jo-Van Distributors**  
Scarborough, Ontario  
Phone: (416) 752-7210  
Toll Free: 1-888-752-7210  
FAX: (416) 752-3845

**Doyle Security Products**  
Minneapolis, MN  
Phone: (612) 521-6226  
Toll Free: 1-800-333-6953  
FAX: (612) 521-0166

**Robert Skeels and Co.**  
Carson, CA  
Phone: (310) 639-7240  
Toll Free: 1-800-734-4539  
FAX: (310) 639-7569

**Fried Brothers, Inc.**  
Philadelphia, PA  
Phone: (215) 627-3205  
Toll Free: 1-800-523-2924  
FAX: (215) 592-1255

SECURITY DISTRIBUTORS, INC., Dallas, TX

wider range of replacement remotes serving many of today's vehicles stated.

An increasing number of GM and Chrysler-Jeep vehicles require scan tools for remote programming. Their new service packs will help locksmiths to provide consumers with an alternative to their local dealerships for their keyless entry needs.

### **2004 Fast Facts**

Sieveking Products Co. proudly introduces the 2004 sixth edition of Fast Facts™ the encyclopedic index of auto and motorcycle key making facts. Fast Facts™ has over 2700 listings (1960-2004), with 425 auto key plates and 147 cycle key plates. The sixth edition is available in the spiral bound 6"x11" desk size and the 3-1/2" x 6 1/4" Perfect Bound Pocket Size.



Fast Facts™ has added many new ITL numbers, Pack-a-Punch information, HPC CodeMax numbers, Aero & Baxter Try-out Keys, Jet and A-1 key numbers. Expanded "Helps" section includes all the latest "Transponders," the newest key numbers, code series, and step by step transponder originate, duplicate, and emergency start methods.

### **Lockcraft Lock Key Catalog**

The new 2004 Lockcraft Automotive Locks and Keys Catalog includes new popular part numbers, enhanced diagrams and images, and cross referencing. Altogether, over 300 new applications have been added and are included.

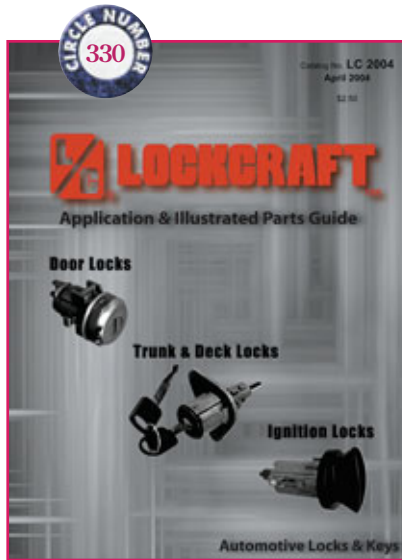

The Lockcraft Application Guide and Parts Catalog is divided into three sections - Application Guide, Parts Catalog and Reference. To determine the correct ignition, door or trunk lock application for a specific vehicle see the Application Guide. To make part search easy, over 50 pages offer a complete listing — by make, model and year in alphabetical order — of all the vehicles for which parts are available. Both coded and uncoded locks are available in chrome or black finish.

The Parts Catalog contains improved images and detailed descriptions of all Lockcraft automotive locks. Don't second guess your order; verify it with a visual in the Parts Catalog section. In addition to locks, the Parts Catalog features domestic and import automotive service kits with a collection of the most needed, and sometimes hard to find, parts to complete a job. Next, Lockcraft key blanks in solid brass and nickel plate are pictured for the most popular manufacturers. Plus, Lockcraft manufactures the only aftermarket VATS key with a lifetime warranty. Finally, Lockcraft provides the locksmith with all the tools necessary to complete a job quickly and correctly, identified in this section by photograph and detailed copy.

Competitor and OE cross-references have been updated in the Reference section. You can use the Parts Cross Reference to check the availability of our OEM-quality Lockcraft parts based on the part number of other automotive lock manufacturers. To make purchasing fast and efficient, an Authorized Distributor list is included in the back of the catalog. For ease of use the list is divided by state.

## **Electronic Security**

### **Kaba Access PowerLever® PROX 9000**

The battery-less PowerLever PROX 9000 combines the convenience of PROX with PIN access to provide dual credential access control for up to 3,000 individual user codes. The lock provides access control flexibility by allowing either single or dual credential access - and is compatible with industry leading brands of exit devices.

Easy to use software simplifies user management, and battery-less operation reduces the lifetime cost of ownership, and the hassle of regular lock maintenance. An extensive 30,000 event audit capacity adds security and peace-of-mind.

Call or visit our website to learn how to make PowerLever dual credential security work for you.





### Adams Rite

Adams Rite is so confident that you will be amazed by the MS® Maglock that if purchased and installed before December 31st 2004, buyers will receive a randomly selected VISA gift card worth anywhere from \$50.00 to 500.00!



Here are the facts: The MS Maglock is only about 2" x 6", but features an amazing 4,000 pounds of holding force while weighing only 4 pounds! That's a

serious size to strength ratio. What does that mean? It will fit almost anywhere while providing maximum security, and its light weight, custom mounting plate and special marking template makes installation a piece of cake. In a nutshell, the MS Maglock is the only maglock you will ever need.

### ASSA Cliq

ASSA is proud to introduce an intelligent lock system that combines the best of design and electronics in the smartest possible manner. They call this technology Cliq. ASSA Cliq technology is built into a new generation of ASSA Twin Cliq lock cylinders to



create a lock system with built-in intelligence. ASSA Cliq is developed from the renowned ASSA Twin cylinders. This means that the same high quality, proven mechanical security, tested and approved by insurance companies, is guaranteed.

All of the technology fits into the present cylinder specifications. As opposed to existing electronic and electromechanical lock technology, ASSA Cliq systems do not require wiring, an external power source or extra equipment of any kind. Just take it out of the box and install. The ASSA Cliq system is easy to use; all the user needs is their personal key. Since every key has its own identity, it becomes the "personal property" of the key holder.

### RS2 Technologies Easy Access Control Package

Access It!® Lite from RS2Technologies is a user friendly, entry-level, out of the box

*Continued on page 30*

# FASTRACK

Hardware Inc.



**Koala Corporation**  
Manufacturers of child care products

# Yale®



**Norton®**  
Powermatic Door Controls



Alarm Lock Systems Inc

**KROY®**  
ADA Regulatory Signs

**LCN®**

**Same Day Shipping**

1-800-458-8707 Fax 800-667-8701

We accept Visa, Mastercard and American Express

Email: [sales@fastrackhardware.com](mailto:sales@fastrackhardware.com)  
[www.fastrackhardware.com](http://www.fastrackhardware.com)



# InstaCode 2004 with our new Master Key Module (Module is an optional feature.)

More Codes!  
More Features!

**Design a grand master system and send it right to your electronic key machine!**

If you haven't seen InstaCode 2004, you haven't seen InstaCode!

**New for 2004...**

- Optional master key module allows you to design a grand master system and send it right to your electronic key machine.

- Add your own code series
- Add your own code cards
- Cad cam graphics of keys show Depth & Space
- More vehicle openings
- New code series

**Additional features...**

- Free internet updates mean no waiting for new codes & features
- Transponder programming info onboard
- Vehicle look up by make, model and year
- ASP part numbers and labor times



Create a Master Key System, first window.

Main permutation.



The solution.

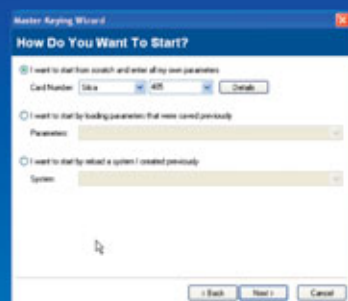

How do you want to start?



Key descriptions and quantities to cut.

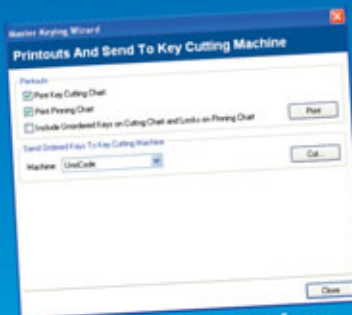
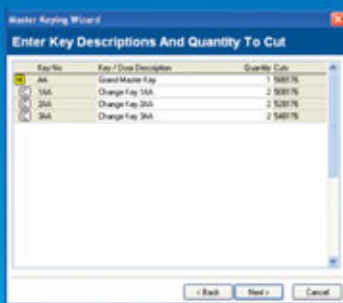

Printouts and send to key cutting machine.



Modify parameters.

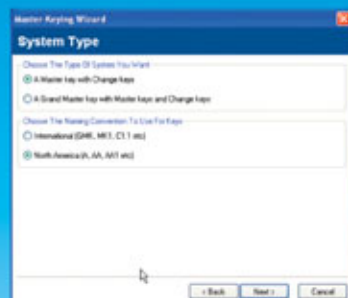

System type.

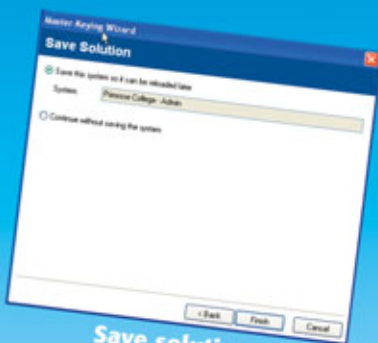

Save solution.

W.H. Software

Learn more

**You deserve the best! You deserve InstaCode!**



# InstaCode 2004 puts the power in YOUR hands!

**The feature list goes on and on.  
How does your software compare?**

**Pay as little as \$18.95 a month!  
Call for details...  
630-837-2044**

FEATURE	InstaCode	The Competition	FEATURE	InstaCode	The Competition
<b>SEARCH OPTIONS</b>			<b>FUNCTIONALITY</b>		
Code number	✓	?	Add your own code series	✓	?
Manufacturer	✓	?	Make your own code cards	✓	?
Model and year	✓	?	Master keying Module included	✓	?
Key blank	✓	?	Build a grand master keying system and download it to your electronic machine	✓	?
Card	✓	?	Password protection available	✓	?
Lock type	✓	?	Sort key blanks into desired order for display	✓	?
Search on any combination of criteria	✓	?	Find partial bitting	✓	?
<b>DATA</b>			Progression chart to eliminate wastage	✓	?
6000 series • 2.5 billion codes	✓	?	Shows picture of cut key	✓	?
99 key blank manufacturers	✓	?	Stores key hook for each key blank	✓	?
Key blank cross reference	✓	?	Stores client information	✓	?
Key blank profile pictures	✓	?	Stores user notes against each series	✓	?
Key blank pictures	✓	?	Supports laser and plunge cut keys	✓	?
Vehicle opening instructions	✓	?	Your choice of display units (inches or mm)	✓	?
Transponder programming instructions	✓	?	Select manufacturer, model, key blank, etc from list by typing in first few characters	✓	?
Complete ASP catalog with color pictures	✓	?	<b>PRINTING</b>		
Airbag safety instructions	✓	?	Print HPC Cards	✓	?
Lock wafer positions	✓	?	Print a whole series	✓	?
<b>ELECTRONIC MACHINES</b>			Print the current code and it's data	✓	?
Silca UnoCode	✓	?	Configurable printer and printer paper tray	✓	?
Silca UnoCode 299	✓	?	Choose letter or A4 size paper	✓	?
Silca UnoCode 399	✓	?	<b>THE SOFTWARE</b>		
Ilco UltraCode	✓	?	Cad Cam drawing of key graphically shows depths and spaces	✓	?
ITL 9000	✓	?	Intuitive user interface	✓	?
ITL 950	✓	?	Live updates from the Internet	✓	?
CodeMax	✓	?	Supports mouse and keyboard	✓	?
ECM 200	✓	?	Microsoft Windows application	✓	?
<b>MANUAL MACHINES</b>			Licensed to run on 5 machines in the same office	✓	?
HPC 1200/Blitz	✓	?	Configurable personality	✓	?
HPC Punch	✓	?	Step-by-step manual	✓	?
Curtis	✓	?	Free phone support	✓	?
Framon	✓	?			
A1	✓	?			

Mail in coupon below OR fax coupon to (630) 837-1210.

**YES Send me InstaCode 2004 with Master Key Module for \$895.00**

**YES Send me InstaCode 2004 without Master Key Module for \$695.00**

Orders must be paid in U.S. Funds.

**My check and this coupon are enclosed for \$ \_\_\_\_\_**  
**Or charge my**  VISA  MasterCard  Discover  American Express

Card # \_\_\_\_\_

Exp Date \_\_\_\_\_

Include \$8 shipping, Canada & Foreign add \$20 add'l for shipping

Signature \_\_\_\_\_

Your Name \_\_\_\_\_

Shop Name \_\_\_\_\_

Address (no P.O. boxes) \_\_\_\_\_

City, State, Zip \_\_\_\_\_

Phone \_\_\_\_\_

E-mail (optional) \_\_\_\_\_

Copy or clip this coupon and send with payment to: The National Locksmith • P.O. Box 77-97592 • Chicago, IL 60678-7592

**CREDIT CARD ORDERS: Fax your order to (630) 837-1210 or Phone your order to (630) 837-2044**



access control software package, designed from the ground up with ease of use as a cornerstone. The package can have up to 32 readers, access levels and time zones and up to 32 time zones. The familiar Outlook style interface, along with clever wizards, results in an operational access control system in minutes instead of hours.

Frequently performed operations, such as adding cards and running reports are transformed into simple, step by step tasks through the use of the built in wizards. The package can be easily upgraded to the company's flagship Access It! Software package.

**SDC's New Electrified Locksets**

The new SDC 7800 series Electrified Mortise Locksets provide building and fire life safety code compliant operation and are UL listed for fire rated doors. The door stays latched even when unlocked, maintaining fire door integrity. Choose from the SDC manufactured lever lockset or



send the brand lockset of your choice to SDC for conversion to electrical operation.

SDC lockset features include: retrofit of major brand mechanical locksets; field reversible fail-safe-failsecure modes; field selectable function - locked on outside or locked on both sides; field reversible handing; Dual 12/24VDC input; lever clutch mechanism; and full monitoring and REX output capability. Applications include office doors, work centers, elevator lobby doors, stairwell doors, exit doors and more.

**Folger Adam Electric Door Controls**

Folger Adam is pleased to introduce a new line of mag locks with simple installation and wiring requirements, featuring dovetailed mounting brackets and internal splice chambers with removable terminal strips on the FAM 38 and FAM 68 Series. Model FAM38: provides 600 pounds of "traffic control" security and is recommended for applications where physical assault on the door is not expected, such as access-controlled interior rooms and secured areas within buildings.



Primary benefits of this model are its lower cost and more compact size. Model FAM68: has a holding power of 1200 pounds, while still offering the same built-in splice chamber and bracket mount design as the FAM38. The FAM68 is appropriate for exterior and perimeter doors through which

criminals could gain entrance to cause substantial economic loss. Entry cannot be forced without special tools or before the door and frame actually gives way.

**New IR Recognition Systems FingerKey DX Reader**

IR Recognition Systems, the biometric component of Ingersoll-Rand's (IR) Security & Safety Group's Electronic Access Control Division (EACD), today announced the debut of its new FingerKey DX fingerprint access control reader, a low-cost biometric alternative designed to secure smaller user populations. The FingerKey DX reader includes a keypad and LCD display. An optional proximity reader, memory and Ethernet upgrades are also available. A user simply enters a PIN code or presents a proximity card, which calls up a template to scan. Then, a user places a finger on the FingerKey reader for verification against that local template. Verification takes less than two seconds.



Two fingers per user can be scanned into the system. Fifty users is the standard configuration, but the FingerKey reader can handle up to 100 users with an optional memory upgrade. FingerKey units can also be linked together via an RS-485 network to share enrollment information. No PC is required to enroll users, as the enrollment reader will automatically download to other FingerKeys in the network.



## Tools & Accessories

### KEEDEX

The Door Laser from Keedex is used for core-drilling doors. The use of a Laser Sight assures accurate drilling. The Door Laser is also affordably priced.

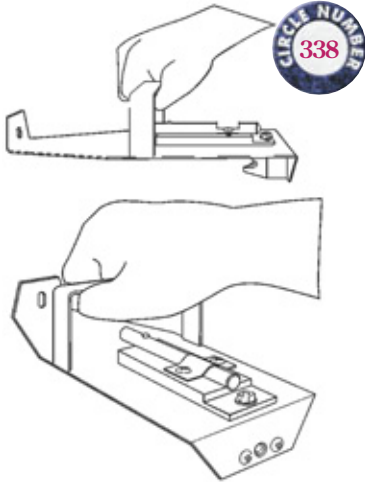

### LockTools

Locktools presents the installation jig series. Their three jig series, the Wild Jig.1, Wild Jig.2, and TimeSaver Jig are designed by a locksmith for locksmiths. Set up time is drastically reduced, the jigs are accurate, rugged, and come with limited lifetime guarantees. The Wild Jig.1 quickly and smoothly bores holes for commercial and residential cylinder locks and deadbolts.

The Wild Jig.2 mortise jig's patented grip-lip centering system assures limited set-up time and accurate cutting. A quick-change, interchangeable plate

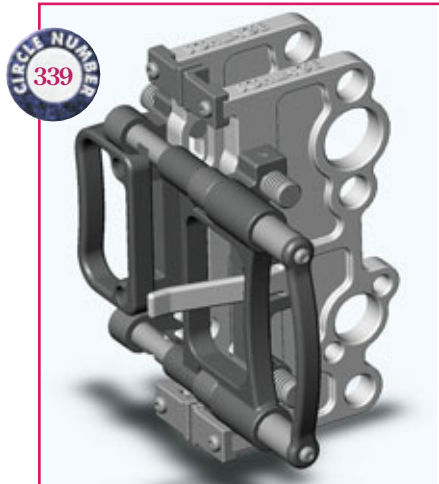

mechanism allows for fast, efficient changeover for different mortise lock installations.

The TimeSaver Jig accurately drills holes for all anchor plate lugs, through-bolts, and electric wire ports for various types of commercial door hardware. All jigs are held on the door using a patented spring-loaded holder.

### HPC Illuminated Pin Station

The Illuminated Pin Station is a multi-function cylinder pinning

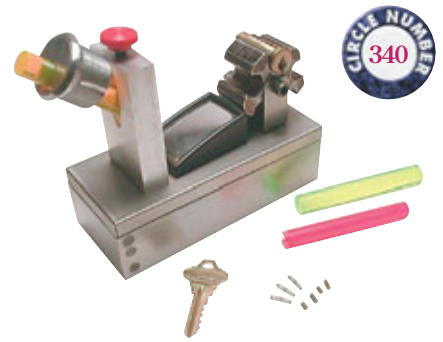

aid. The base opens to reveal a storage area for tools. The center hole secures the station to your workbench, and allows it to

We're back.

We're better.



We're  
**Lockcraft**

Lockcraft shakes up the market:

Our expanded line-up of priced-right automotive locks, keys and service tools opens up better opportunities for you. And our 5-day/90% order fill includes OEM quality replacements for Daimler Chrysler, Ford, GM, Honda, Nissan, Toyota and many more.



**Better get reacquainted  
with Lockcraft!**

**VISIT OUR BOOTH 1120 AND 1122  
AT ALOA FOR SPECIAL OFFERS!**

Lockcraft  
2345 N. Central Avenue  
Brownsville, TX 78521  
Phone: 877-567-5470  
Fax: 512-233-2414



**LOCKCRAFT**  
TM

pivot for easy access to both sides of the station. On one side is a rotating plug holder to hold the five most common sizes of cylinder plugs:

- .404" / 10.26mm
- .504" / 12.80mm
- .508" / 12.90mm
- .512" / 13.00mm
- .556" / 14.12mm

On the other side is an angled holder for plug followers. This eliminates the need to hold the cylinder housing while loading the springs and pins. The illumination comes from the three followers included in the station, in diameters of:

- .395"/10mm
- .495"/12.6mm
- .550"/14mm

These unique followers are made of a bright translucent plastic that illuminates the interior of the cylinder housing. In the center of the workstation is an angled mirror that reflects the ambient light in the room into the followers, providing exceptional light in the inside of the cylinder housing. Having more light in the cylinder housing makes loading the springs and top pins much easier.

### **Multi-Tool by Lockmantools**

The locksmith Multi-Tool by Lockmantools has over 25 specific locksmith functions. Designed by a locksmith for locksmiths, the tool can service a variety of different hardware for Schlage, Baldwin, Corbin/Ruswin, Lori, Adams Rite,



Master padlocks, Medeco, Arrow, Jackson crossbars and many others, the company says.

The tool is made of bead blasted stainless steel for extra durability and folds up to 4 inches closed. A ballistic cloth carrying case clips onto the user's belt for fast access and convenience.

### **Major Manufacturing The Pit Bull**

Major Manufacturing has the solution for your lock installations in steel doors. The Pit Bull tool is used to form a rectangular pocket in the edge of a hollow metal door. Application of



the tool is almost effortless - simply drill the latch and cross bore holes and install the Pit Bull. Using a few turns with a wrench will squeeze an indentation into the door's edge - the result is a pocket that will accept both 1" and 1-1/8" wide by 2-1/4" tall latches.

### **CapSaver Plus Press from A1 Security**

True to its recognition of innovation, A1 manufactures a truly innovate and time-saving machine for capping I/C cores (SFIC) Seating up to 7 individual caps is time consuming and costly for higher volume shops. With A1's CapSaver Press (#CAP5) the time required to seat 7 caps is completely eliminated. According to A1, this equipment is used by the vast majority of I/C Core manufacturers.



The press uses strips to form the caps as it seats them. Strips are more economical than caps, but the real benefit is realized in your cost of labor.

### **Gil-Ray Tools Online**

Gil-Ray Tools has been sharpening and manufacturing new OEM replacement cutters for over 58 years. They feature many of their cutters on their Internet website. Recent new cutter wheels added to their stock include longer lasting M3 type 2 high speed steel cutters for Bollini, Taurus, Bravo 2, and Rytan key machines. These cutters offer longer lasting durability when compared to the stock cutters that come with the new machine.



**Continued on page 34**



**ABUS****ADAMS RITE****ARROW****CompX CHICAGO****Corbin RUSSWIN****DOR-O-MATIC****FALCON****CompX FORT****GLYNN-JOHNSON****IVES****JET****KABA ilco****KABA ACCESS CONTROLS****KEEPER****KSP****Kwikset****LAB****LCN****LOCKNETICS****Master Lock****MONARCH Exit Devices & Door Hardware****CompX NATIONAL****Norton****REXSON****RCI RUTHERFORD CONTROLS****SARGENT SCHLAGE. SECURITRON****SELECT PRODUCTS LIMITED****GE Interlogix Supra****CompX TIMBERLINE****VON DUPRIN. Yale**

Receive **FABULOUS GIFTS** When You Purchase Stock Products From These Select Vendors in July & August!!!

Contact Your Local IDN Distribution Center for Complete Details!

**NOW 48 LOCATIONS IN THE US & CANADA!**

Albuquerque, NM  
505-816-0100

Atlanta, GA  
404-898-8740

Buffalo, NY  
315-455-9305

Calgary, Alberta  
403-291-4844

Chicago, IL  
708-456-9600

Cincinnati, OH  
513-271-8530

Cleveland, OH  
216-335-9740

Columbus, OH  
614-436-6619

Dallas, TX  
972-664-1240

Davenport, IA  
563-391-8366

Denver, CO  
303-922-3041

Detroit, MI  
586-755-3658

Edmonton, Alberta  
780-944-0014

Fort Worth, TX  
817-284-5696

Grand Rapids, MI  
616-534-1067

Halifax, Nova Scotia  
902-468-1373

Hartford, CT  
860-296-7886

Houston, TX  
713-668-0022

Indianapolis, IN  
317-635-8100

Jacksonville, FL  
904-387-0663

Kansas, KS  
913-599-4111

Las Vegas, NV  
702-736-4553

Livonia, MI  
(3 locations)  
734-591-1150

Los Angeles, CA  
562-463-4870

Memphis, TN  
901-795-2250

Miami, FL  
305-651-1598

Milwaukee, WI  
262-790-9750

Minneapolis, MN  
952-886-3840

Montreal, Quebec  
514-956-0248

New Orleans, LA  
504-837-7315

Norfolk, VA  
757-853-0611

Oklahoma City, OK  
405-942-8750

Omaha, NE  
402-592-1652

Orlando, FL  
407-297-7722

Ottawa, Ont.  
613-749-2172



IDN reserves the right to withhold premiums for delinquent, past due accounts. IDN also reserves the right to substitute premium products of equal value.

## Software Products

### InstaCode 2004

A good code program is a must for any professional locksmith, and InstaCode is a high quality easy to use program. If you are still using code books or an outdated code package, why not move up to the most comprehensive and easy to use code program available.



A master key wizard has been added to create your key systems in just minutes then produce comprehensive key cutting and lock pinning charts. You can even download your keys to an electronic machine then save the codes for future reference.

A new graphical layout displaying space and depth information, flat widths, card number and other valuable key cutting information.

Identify and key number now without knowing the manufacturer's name.

We have added 100's more code series, new car opening instructions, more makes and models of vehicles, new transponder key information and programming techniques (optional extra), the full ASP catalogue, with most models featuring colour pictures of the ASP locks and service components.

InstaCode 2004 has been redesigned to make it even easier to use, with the entire user interface being revamped and simplified. With InstaCode 2004's additional code series the total is now over 5000 indirect code series, making a total of over 2 billion direct and indirect codes!

Lastly, InstaCode 2004 also features an interactive web update feature, which periodically checks this website for updates, ensuring you always have access to the very latest version and newest code series available for the forthcoming year.

Check out some of the new features below:

InstaCode 2004, the latest release of InstaCode, includes nearly 6000 code series, and has a vastly increased database of key blank cross-references. The program has also been improved to provide better performance, reducing search times.

The program has been improved so much, we are more confident than ever that you will find this to be "The World's BEST Code program", and that the program is without compromise in terms of quality, ease of use, speed and quantity of information contained within.

### Kaba Ilco SDD Software Update



Kaba Ilco has released a new SDD Software update ver 10.01. This is the latest internal software update for the SDD diagnostic tool. The SDD Software update includes new software for programming keys for 2003 & 2004 Chrysler products. Also included within the update is new software for programming 4 cylinder and ULEV (Ultra Low Emissions Vehicles) Honda Accord vehicles.

All registered SDD owners will receive this update free of charge. For information concerning this free update please contact Ilco's Customer Service Department or Ilco's Technical Assistance Department. Packaging - The update is packaged one per envelope and is serial number specific.

## Keys & Key Accessories

### KEY-BAK

When asked for the secret of his success, a famous American industrialist of the 1940's declared, "Find a need and fill it." Among those who heeded Henry J. Kaiser's advice was a California railroad man, Russ Lummis, founder of their company. More than fifty years ago, he saw a need for brakemen and switchmen to have a better, safer, and more convenient way to handle their keys. The dangling key chains they wore sometimes caught on moving trains. Lummis filled that need by inventing KEY-BAK®. It was an instant success, first in the railroad industry and then in other industries, wherever keys were part of the job.



Today they continue to fill the need by introducing their new Counter Display that feature 7 of their best selling items. Each fully stocked Counter Display comes with 6 of each item and includes a handsome header card.

### Klassy Keys Unveils Five New Key Designs

Klassy Keys has introduced five new designs for the American Classic Collection. The

Continued on page 36



For years locksmiths have begged for comprehensive service manuals on motorcycles, and they are finally here! Covering a wide range of service procedures, you'll know everything a locksmith needs to know about each cycle. Plus, you'll get step by step photographs and instructions.



# The National Locksmith®

# Guide To Motorcycles

## Volumes 1, 2, 3 & 4

by John Blankenship

### Volume 1 covers...

Key information • Progression Charts • **BMW** 1997 R1100R • **Harley-Davidson** 1938 Knucklehead, 1970 Sportster, 1980 Sportster, 1984 Wide Glide, 1994+ Tubular Ignition Lock • **Honda** 1968 Mini Trail 50, 1970 Trail 90, 1971 CB750, 1978 CB750, 1978 Hawk, 1981 CB900, 1982 Ascot, 1983 Shadow, 1984 Nighthawk, 1985 Rebel, 1990 Gold Wing, 1996 Nighthawk 750, 1996 VFR750 • **Kawasaki** 1980 LTD250, 1985 Ninja 600, 1993 KLX650 Ignition Lock, 1994 Ninja Gas Cap • **Neiman** Steering Lock • **Suzuki** 1986 Intruder, 1990 Katana 600, 1991 GSXR1100 Ignition Lock, 1998 Katana 600, 1999 TL1000R • **Triumph** 1995 Tiger, 1999 Legend • **Yamaha** 1980 650 Twin, 1987 FZR1000 Ignition Lock, 1987 Virago, 1992 Yamaha/Polaris 4-Wheeler Ignition Lock, 1998 V Star Classic, 1998 YZF600R

### Volume 2 covers...

Key information • Progression Charts • **BMW** 1976 R90/6, 1989 K100RS, 1995+ Ignition Lock, 1999 F650, Luggage using Y61 • **Buell** 2000 Blast • **Ducati** 1993 Monster • **Harley-Davidson** 1999 Road King Police, 1999 Sportster • **Honda** 1975 CB550 Ignition Lock, 1980 CB400 Ignition Lock, 1983 CB650 Ignition Lock, 1985 Aero Ignition Lock, 1995 Gold Wing Luggage, 1987 250X 4-Wheeler, 1990 NS50, 1992 Shadow, 1994 CB250, 1997 Shadow, 1998 CBR1100XX, 1999 CBR600F4, 1999 CBRX1100XX, 1999 Shadow, 2000 CBR600F4, LIPO 5-cut Ignition Lock, LIPO 8-cut Ignition Lock, • **Kawasaki** 7-cut Code Information, 1980 LTD250 Ignition Lock, 1983 GPZ Ignition Lock, 1986 ZX600R Gas Cap, 1986 ZX600R Ignition Lock, 1987 EX500 Ignition Lock, 1989 EX500, 1991 ZX-6, New Blank • **Suzuki** 1968 T500, 1981 GS550 Ignition Lock, 1986 GSXR750RG Gas Cap, SM-2 Ignition Lock, SM-4 Ignition Lock • **Triumph** 1970 Bonneville, 1973 Tiger, • **Yamaha** 1980 XS650, 1982 Seca 400, 1982 XV920 Ignition Lock, 1984 FJ600, 1986 FJ1200 Gas Cap, 1989 Riva Jog Ignition Lock, 1990 XT350, 1993 Seca II, 1996 Royal Star, Cruiser Ignition Lock • **Zadi** Q637 Ignition Lock, Q933 Ignition Lock

### Volume 3 covers...

Key information • Progression Charts • **BMW** 1999 R1100GS, Luggage using X59 • **Honda** 1975 CB500T Ignition Lock, 1980 CB750 Custom Ignition Lock, 1980 CM400T, 1983 CB450 Nighthawk Ignition Lock, 1985 Big Red, 1987 Elite 250, 1987 Elite 250, 1997 CBR600F3, 1999 Shadow ACE Deluxe, 2001 CBR1100XX, 2001 Gold Wing, 2001 XR100, 2002 VTX1800, Cruiser Ignition Lock • **Kawasaki** 1979+ Ignition Lock, 1982 KZ1000 Ignition Lock, 1986 ZL600 Ignition Lock, 1992 ZX6 Seat Lock, 1995 KLR250 Ignition Lock, 1998 ZX9R Ninja, 2000 Concours, 2001 250R Ninja, 2001 500R Ninja, 2001 KLR650, 2001 ZX12R Ninja, KM-5 Ignition Lock • **Moto Guzzi** 1979 V 50 II • **Suzuki** 1979 GS750 Ignition Lock, 1985 Ignition Lock, 1986 GSXR750, 1990 GSXR750, 1997 DR650, 1999 Savage, 2001 GSXR750, SM-5 Ignition Lock • **Yamaha** 1972 Enduro 100, 1977 Enduro 400, 1978 XS750 Triple, 1982 XZ550 Vision Ignition Lock, 1984 QT, 1989 V Max, 1992 TW200 Ignition Lock, 2002 BearTracker

### Volume 4 covers...

Master Index • Key information • Progression Charts • Corrections & Updates • **Aprilia** 2000 Pegaso, Luggage • **Ducati** 1991-2002 Ignition Lock, 1997 Monster, 2001+ Transponder Models, 2002 748 • **Givi** Luggage • **Harley-Davidson** 2002 Ultra Classic Electra Glide • **Honda** 1978 Trail 90, 1981 CB750 Gas Lock, 1984 V65 Sabre, 1986 VF1000R Interceptor, 1988 GT650 Hawk, 2001 VTR100F Super Hawk, 2002+ CBR954/1000 Key Blank, 2002 Metropolitan, 2002 Reflex, Honda 22222-00000 Codes, Honda H Codes, Honda T Codes, • **Kawasaki** 1973 Mach III Ignition Lock, 1980 KZ650, 1980 KZ1000-E2 Seat Lock, 1983 KZ750 LTD, 1995 GPZ1100, 2001 ZRX1200R, KM-2 Ignition Lock, KM-4 Ignition Lock • **Malaguti** 2002 Lock Set • **Moto Guzzi** 1973 V7 Sport • **Suzuki** 1999 King Quad, 2001 SV650S, 2002 GSXR600 • **Triumph** 2003 Bonneville T100 • **Yamaha** 1982 Virago, 1993 FZR600, 2002 FZ1, 2002 Vino

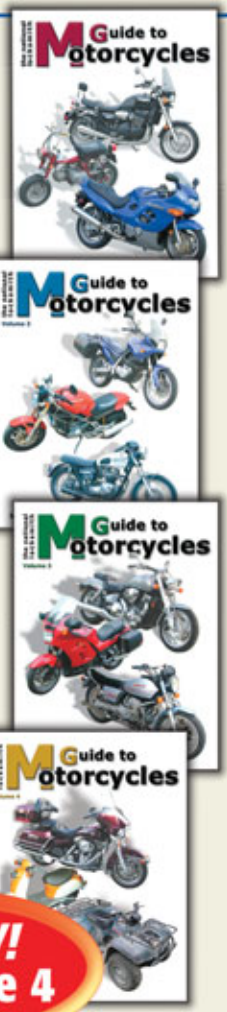

Buy all 4 volumes in the online store! [TheNationalLocksmith.com](http://TheNationalLocksmith.com)

OID 7/04

- Any Single Volume \$99.00 + \$8 s/h
- Any Two Volumes \$149.00 + \$8 s/h
- Any Three Volumes \$199.00 + \$8 s/h
- All Four Volumes \$249.00 + \$8 s/h

### Choose the Volumes you are ordering...

- Vol. 1  Vol. 2  Vol. 3  Vol. 4
- Complete Set of All 4 Volumes

Please choose a format:  Book  CD-ROM

(U.S. add \$8 s/h per order. Foreign & Canada add \$20 s/h per order. Orders must be paid in U.S. funds)

- I've enclosed a check or money order for \$\_\_\_\_\_
- OR charge my  VISA  MasterCard
- Discover  American Express

Credit Card # \_\_\_\_\_  
 Expiration Date \_\_\_\_\_  
 Signature \_\_\_\_\_  
 Your Name \_\_\_\_\_  
 Shop Name \_\_\_\_\_  
 Address (No P.O. Boxes) \_\_\_\_\_  
 City \_\_\_\_\_  
 State \_\_\_\_\_ Zip \_\_\_\_\_  
 Phone (\_\_\_\_) \_\_\_\_\_

Mail coupon & payment to: **The National Locksmith** • P.O. Box 77-97592 • Chicago, IL 60678-7592





flame key is geared toward motorcyclists and car enthusiasts. In addition to the new flame key, Klassy Keys offers something for everyone from race fans, golfers, nature lovers, and sports fans.

**HPC, Inc. Keyable Key Cabinets**

Most places of business and institutions utilize strict procedures to control the access to and distribution of the keys to the numerous doors in their facilities. Key cabinets provide secure storage for their keys. However, the cabinets require a separate key, which must be carried, and controlled to avoid compromising the security of the entire facility. HPC's new Keyable KeKabs eliminate the problem of how to control the key to the key cabinet.



This new line of cabinets allows you to add your own mortise cylinder, and key them into the existing master key systems. The Keyable KeKabs are equipped with a heavy-duty lock assembly, and are designed to use standard 1-inch mortise cylinders with an Adams Rite cam. Longer cylinders can be accommodated using spacer rings. The mortise cylinder, keys,

and spacer rings are not supplied with this cabinet. The cabinets use slotted tags and key rail to provide uniform storage of keys. This allows users to quickly determine which keys are out of the cabinet.

The Keyable KeKabs are available in capacities of 65, 95 (expandable to 265), and 265 keys. All cabinets include numbered plastic key tags, with metal snap hooks, out tags, and a record-keeping booklet.

Add convenience and security to the storage of your customers' keys with the HPC's Keyable KeKab.

**Andrew's Groovy Keys**

Andrew's Wholesale Lock Supply has four exclusive Groovy Keys patterns from Jet, including Shamrock, Cards, Race Flag and Dice. Keys are available in KW1, SC1, M1 and WR5 and are priced with attractive margins to help boost impulse sales. According to Andrew's, the keys cut cleanly



and evenly so a locksmith doesn't have to worry about losing the pattern when a key is put on the wheel for deburring. Andrew's offers point-of-purchase displays for the keys.

**New Lund Key Cabinet**

The new Lund Key Cabinet has a locking inner compartment and a



locking exterior door as well. Designed to safeguard keys to private records, valuable papers, medical offices, engineering designs, etc. It leaves the keys in the outer compartment accessible.

The locks are keyed differently, the locking inner compartment has 50 hooks, and the hinged panel has 100 hooks. The cabinet is made of 18-gauge steel, with a gray baked-on enamel finish.

**New Exacta Kits for Ilco MK1 and 029A**



Kaba-Ilco has recently introduced several new code accessory kits for use with their popular Exacta MK1 and 029A code machines. These kits are designed to originate keys for a variety of newer General Motors automotive lock applications. The kits include a printed code book, and all required code attachments for each kit's intended application.

These new products further expand the broad coverage and convenience provided by both code machine models.

Application.....	029A KIT#.....	EXACTA KIT#
Saturn Ion.....	029A-GM3.....	MK1-SAT/GM-AE-03
GM Daewoo .....	029A-GMD .....	AT MK1-GMDAT-AE
Pontiac Grand Prix, Chevy Malibu, Cadillac SRX.....	029A-GM2 .....	MK1-GM-AE-04
Chevy Colorado, GMC Canyon.....	029A-GM4 .....	MK1-GMTO-AE-04



# STOCK LOCKS®

Standard Locks for Special Needs

**Shipped In  
24 Hours**

# The World's Most Complete Stock Program

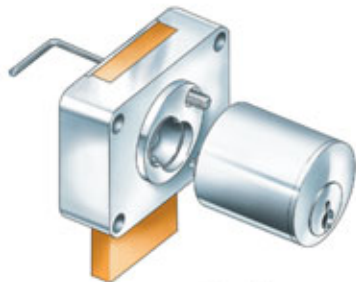

**CompX**  
NATIONAL

**FULL PRODUCT LINE  
OF SECURITY LOCKS**

**"THE ADVANTAGE PLUS"**

100 years ago **National Lock** began making quality cabinet locks and in 1968 founded the STOCK LOCKS® program, offering pin tumbler and plated disc tumbler cabinet locks plus a complete line of mail box locks.

With the addition of **Fort Lock** in 1998 the program was expanded to include STS capped single and double bitting disc tumbler locks and showcase locks.

With the addition of **Timberline Lock** in 1999 came a complete offering of small diameter, core removable replacement wood furniture locks and mechanisms.

With the addition of **Chicago Lock** in 2000 the popular ACE® tubular lock products were added to the STOCK LOCKS program.



**Poly bags are color coded  
by company and bar  
coded. Multiple finishes  
available in stock.**

Together, under the **CompX Security Products'** umbrella, we offer over 1500 stock keeping units and represent 252 years of cabinet lock manufacturing experience beginning in 1903.

STOCK LOCKS is the broadest coordinated program of cabinet locks in the world, and **you can insist on the STOCK LOCKS brand** for your security needs.

**We were there for you then — and we're here for you now!**

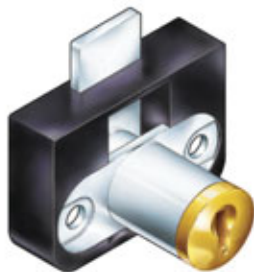

**CompX**  
TIMBERLINE  
LOCKS FOR  
WOOD FURNITURE



**CompX**  
FORT

**MULTI-FUNCTION CABINET LOCKS**



**CompX**  
CHICAGO

**HIGH SECURITY LOCKS TO  
THE VENDING INDUSTRY**

**CompX**  
SECURITY PRODUCTS

200 Old Mill Road  
P.O. Box 200  
Mauldin, SC 29662  
PH (864) 297-6655  
FAX (864) 297-9987

Western Distribution Center  
9370 Buffalo Ave., Unit 104  
Rancho Cucamonga, CA 91730  
PH (909) 476-7933  
FAX (909) 476-8553

[www.compxnet.com](http://www.compxnet.com)

Circle 214 on Rapid Reply

# 2001 Toyota MR2

## part 2

by Michael Hyde & Alan Morgan

**L**ast month we covered the door lock and ignition switch. This month we complete the ignition disassembly, service the trunk lock-out switch and remove the ECU.

## Ignition Disassembly

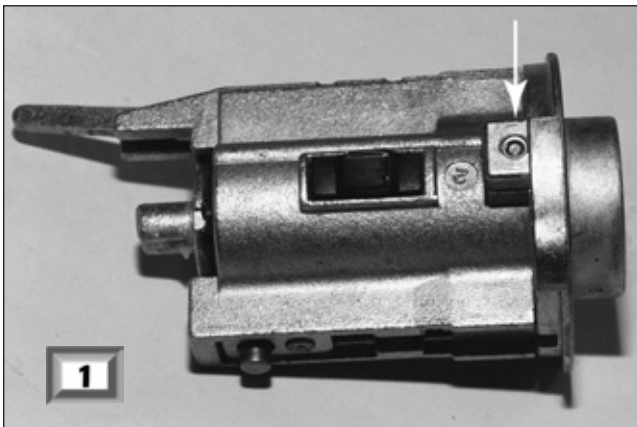

The hardened face cap is held in place with two solid roll pins.

42 • Visit [www.TheNationalLocksmith.com](http://www.TheNationalLocksmith.com)



Start by removing the circular clip at the rear of the ignition plug.

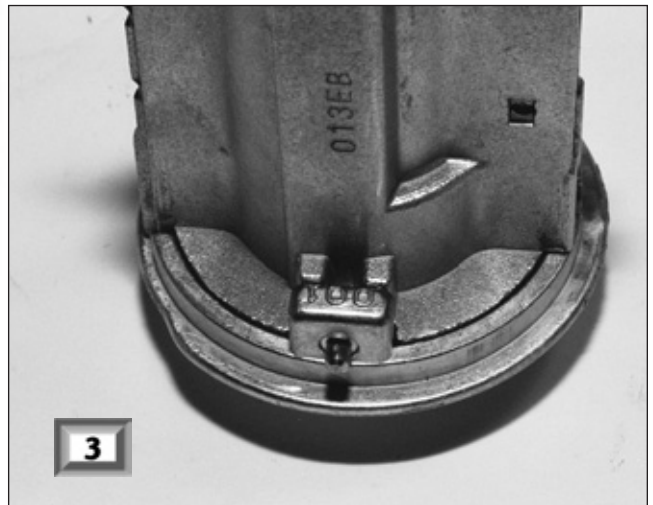

Next remove the roll pin near the "100" stamped on the tab. This can be done easily by inserting a pick and pressing outward on the bottom of the pin.



For the other roll pin an access hole must be drilled into the side of the ignition cylinder body. By drilling perpendicular to the base of the pin you can create an access hole. Now use your pick and push the pin outward from the bottom, similar to the first pin.



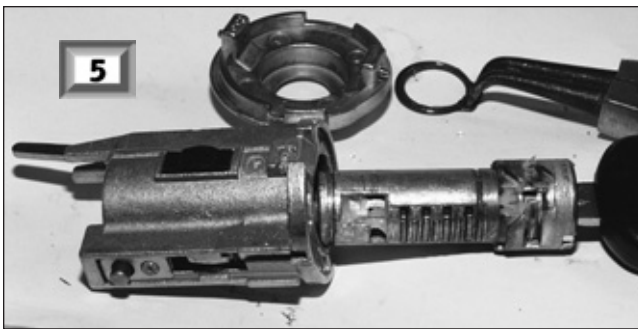

Now with the cap removed the plug comes out the front of the lock.

## Trunk Lock-Out Switch Lock



This vehicle does not have a trunk lock. But it does have a Trunk Lock Out Switch Lock.



The easiest lock to remove is the trunk lock out release located on the driver's side floor. Start by gently prying upward on the plastic cover.

## AMSEC GUN SAFES

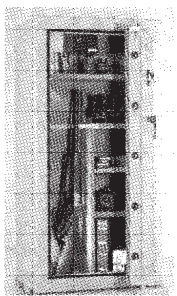

Large Selection  
In Stock

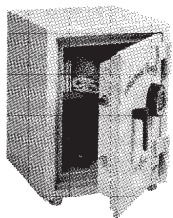

Over 300  
Amsec  
Safes  
In Stock  
Overall

Also Stocking Gardall

Fradon Lock Co., Inc.  
Syracuse, NY  
(315)472-6988 or  
(800)447-0591 East of Mississippi

What goes into more than 200 years of Italian tradition, craftsmanship and innovation?



Keys.

Call 1.800.891.2118 or visit [www.bianchi1770usa.com](http://www.bianchi1770usa.com) today to learn more about our key cutting solutions.



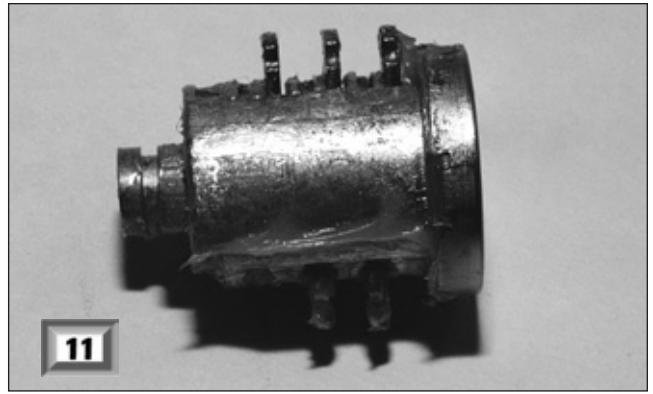

There are 5 tumblers in this position, numbers 4, 5, 6, 7 and 8. If you wish to make a key using this lock you will need to do a progression, which may be quite lengthy, depending on which software you are using.

## ECU Removal



Next remove the single 10mm bolt that secures the lock to the car floor



***"Remember To Disconnect The Negative Battery Terminal Before Removing The ECU"***

Most Toyota ECU's are found behind the glove box, but in this mid-engine car the ECU is located under the luggage compartment, behind the driver's seat.

Removing the "E" clip that holds on the tailpiece easily disassembles the trunk lock out switch lock.



The plug then comes out through the front of the lock.



Start by removing the bolts of the bottom panels of the luggage compartment.



**Curtis Industries**  
A Barnes Distribution Company



**BARNES**  
GROUP INC

# **Curtis #15 Code Cutter has been Re-designed!**



## **The New #15XL**

- Has a longer punch & extended length casting
- Accepts today's larger head keys
- Uses your existing cams and carriages
- Comes with a two year warranty
- Made in the U.S.A.

## **Overstock Sale!**

### **Used Equipment:**

- Ultracode Key Machines more than 50% off list . . . under \$2000!
- #15 Code Cutters . . . under \$300!

### **New parts . . .**

- Cams & Carriages as low as \$48.95!
- Key Machine & Code Cutter Parts
- Code Books
- Key Blanks
- Auto Lock Parts

**Call for pricing & availability**

**We're Listening to You!**

**New, Locksmith Friendly Key Packaging!**

**Stackable boxes for 50 pack keys are back by popular demand.**

**Locksmith Hotline** Phone: 800-555-KEYS (5397) Fax: 800-867-6020

Continued from page 44

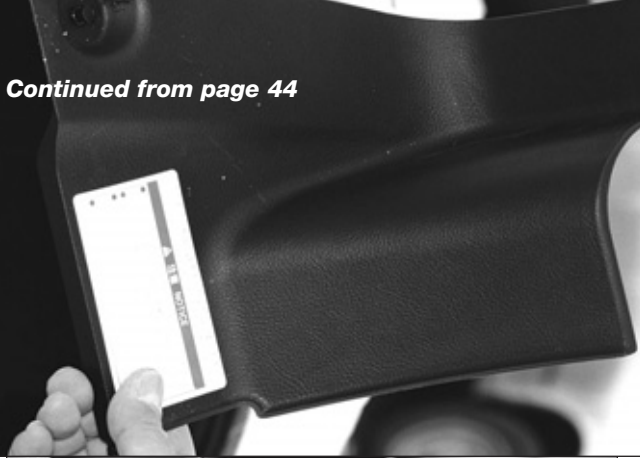

Then remove the luggage compartment side panels.

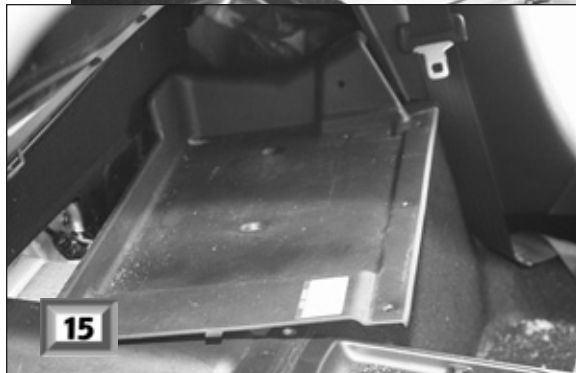

Now the bottom panels can be removed.

46 • Visit [www.TheNationalLocksmith.com](http://www.TheNationalLocksmith.com)



Here is a picture of the storage compartment without any of the panels. Talk about roomy; Toyota must have had the entire family in mind when they designed this car. **"You Did Disconnect The Battery, Didn't You?"**



The ECU can now be easily removed. Remove the 10mm bolts securing the ECU to the car frame, and then disconnect the four separate connectors that fit into the right side of the ECU. These connectors are all different, so you don't need to worry about mixing them up.



The ECU will say "Engine Control" on the label.





After receiving the reflashed ECU back from National Auto Lock you will need to follow the included instructions. This includes watching the "security light". This light is not labeled but located under the fan control on the dash.

# Making The First Key

**Method 1:** Remove Trunk Lock Out Switch and progression the missing tumblers.

**Method 2:** Remove the passenger side door panel and read code stamped on door cylinder.

**Method 3:** Use the Determinator to determine the cuts in the door locks.

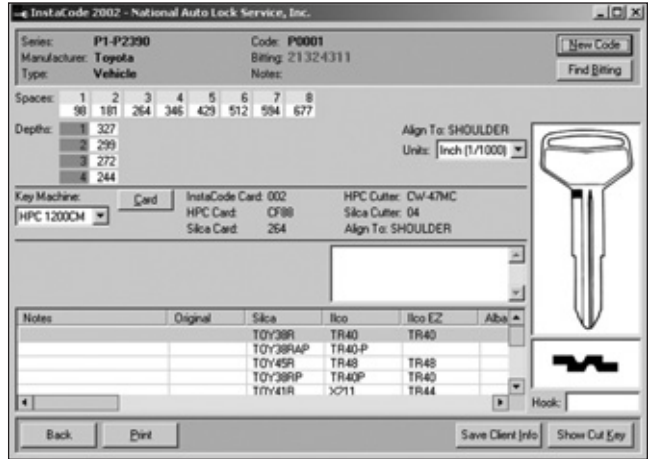

TNL

## Vital Statistics

**Manufacturer:** Toyota  
**Code Series:** P001-2390  
**Key Blank:** Jet: TR40-PHT  
**Number of Cuts:** 8  
**M.A.C.S.:** 2  
**Key Gauged:**  
**Center of First Cut:** .098  
**Cut to Cut Spacings:** .083  
**Cut Depth Increments:** .028

— Framon —

**Cuts Start at:** .098  
**Spacing:** .083  
**Block #:** 5  
**Cutter:** FC8735  
**Depth Increments:** .0277  
**Key Clamping Info:** Use flip up shoulder stop.

— Curtis —

**Cam-Set:** DC-50  
**Carriage:** Toy-50

— HPC 1200CMB —  
**Code Card:** XF88  
**Cutter:** CW-47MC  
**Jaw:** A  
**Gauge From:** Shoulder

— A-1 Pack-A-Punch —  
 PAK-T2

— HPC Punch —

**PCH Card:** PF88L  
**Punch:**  
**Jaw:** A

**Spacings: Depths:**

1 - .098      1 = .327  
 2 - .181      2 = .299  
 3 - .264      3 = .272  
 4 - .346      4 = .244  
 5 - .429  
 6 - .512  
 7 - .594  
 8 - .677

— HPC CodeMax —

**DSD #:** 247  
**Jaw:** A  
**Cutter:** CW-47-MC  
**ITL:** 196  
**UnoCode:** 264  
**Vice Adaptor:** V100 - Std

### YOUR BEST VALUE

*Designed With The Professional Locksmith in Mind*

- ◆ Hardened Solid Steel and Brass Lock Bodies
- ◆ Quality Chrome & Duplex Nickel Plating
- ◆ Double Ball Bearing Locking Mechanism
- ◆ Rekeyable 6-Pin Brass Cylinder With Anti-Pick Pinning
- ◆ Hardened Steel Shackle
- ◆ Quick Change Shackles

## FEDERAL LOCK™

COMPANY

### CALL TOLL FREE (888) 562-5565

Phone: (570) 253-5424 • Fax: (570) 253-4292  
[www.FederalLock.com](http://www.FederalLock.com)



# Software from The National Locksmith®

Buy 'em all  
in the online store  
[TheNationalLocksmith.com](http://TheNationalLocksmith.com)

## Pocket InstaCode

Item #PCODE-03

\$495.00 (Non-InstaCode Owners) Single User

\$349.00 (InstaCode Owners) Single User

Call for Multi-User Pricing

Slip InstaCode in your pocket! Sick and tired of carrying a laptop around with you? Or tired of calling the shop to retrieve a code? Pocket InstaCode has all the important features of the InstaCode program, packed into a program small enough to run on a Pocket PC. Pocket PCs are the size of a "Palm Pilot" style device (slightly larger than a mobile phone), yet advances in technology allow them to be almost as powerful as a laptop PC. Pocket InstaCode takes advantage of these new technologies by providing the locksmith with a powerful, feature packed and extremely compact solution for code and information retrieval.

Pocket InstaCode requires a Pocket PC with 64mb RAM running Microsoft Pocket PC2000 or later. Not included.



## ProMaster 5

Item #PM-5 • \$1895.00

ProMaster 5 is a total master-key system management tool. You and your clients deserve the best. ProMaster 5 is without a doubt the most comprehensive and easy to use master-key system management tool available anywhere in the world. ProMaster 5 is powerful, versatile and robust, and has been designed to meet the requirements of lock manufacturers and professional locksmiths world-wide.

Features: • Multi-user with Local or Wide area networks • Full history & door hardware recording • Automatic or manual coding • Support for most electronic key machines • High quality reports can be e-mailed, printed or exported • Import and export systems individually • Import systems directly from lock manufacturers • Support for multiple databases & multi-profile systems • Comprehensive instruction manual • Unlimited master-key system size • Supported locally in most countries or contact WHS direct



## InstaCode 2004

Item #IC-2004 • \$695.00

(without Master Key Module)

Item #IC-2004-MK • \$895.00

(with Master Key Module)

If you haven't seen InstaCode 2004, you haven't seen InstaCode!  
New for 2004...

Optional master key module allows you to design a grand master system and send it right to your electronic key machine • Add your own code series • Add your own code cards • Cad cam graphics of keys show Depth & Space • More vehicle openings • New code series

### Additional features...

Free internet updates mean no waiting for new codes & features • Transponder programming info onboard • Vehicle look up by make, model and year • ASP part numbers and labor times



## Dave McOmie Safe Book Collection on CD

Item #DMCD-1 • \$899.00

This CD contains every book Dave has ever published. It contains over 2,300 pages, an Easy Index, safe/vault opening instructions, and about 6,000 photos.

(NSO members call for special pricing)

Includes: • **The National Locksmith** Guide to Safe Opening, Volumes 1,2,3,4, and 5 • **The National Locksmith** Guide to High Security Safes, Volume One • **The National Locksmith** Guide to High Security Safes, Volume Two • Dave McOmie's Penetration Party • Dave McOmie on Vault Doors, Volume One: Bank Vaults • Dave McOmie on Vault Doors, Volume Two: Plate and Fire Vaults • Dave McOmie on Gun Safes



## The National Locksmith® on CD

Item #TNL-CD2 • \$99.00 (1988-2002)

Item #TNL-CD4 • \$25.00 (2002)

An eight CD-ROM set. Contains 15 years (1988-2002) of the Locksmith's favorite magazine. Over 14,500 pages of indexed and searchable articles complete with photos. Use the index to locate any topic you want to read about. You'll get cool locksmith internet links allowing you to visit important sites with a single click. If you already own 1988-2001 Back Issues on CD then order the 2002 CD to update your Back Issue collection for only \$25.



## Dave McOmie NSO & Article Collection on CD

Item #DMCD-2 • \$699.00

Includes: • Every NSO National Safeman newsletter since it began in 1992. Each newsletter features detailed safe and vault opening photos, drill points and procedures on a wide variety of safes from the normal to the very high security; • Every McOmie File published by the NSO which gives you all the known opening methods on a virtually every important safe lock mode, mechanical and electronic, with X-ray views; • Every article Dave has written for **The National Locksmith** from when he started in 1986 right up to 2000. (NSO members call for special pricing)



## AutoEdge on CD

(Automotive Locksmith Software)

Item #AE-CD • \$125.00

This CD contains over 1,000 pages of automotive locksmith service. Techniques covered include code locations, lock and column disassembly, lockouts, and much more.

Shows you how to service domestic, foreign, and even high security vehicles with ease. All known key blanks are given, as are all details you would need to work on the vehicle.

As a special bonus, when you purchase the AutoEdge on CD-ROM, you'll also be enrolled FREE in the National Locksmith Automobile Association (NLAA). You will receive 12 monthly newsletters over the course of the next year. Each one covers an important vehicle from top to bottom.

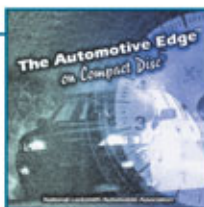

## 15 Minute Safe Opening Technique

CD VERSION Item #JJ-CD1 • \$99.00

PRINT VERSION Item #JJ-1 • \$99.00

This book deals exclusively with round head lift out doors. Shows five ways to open a Major; three ways to find the Dog Pin on a Major; four ways to open a Star; four ways to open a LaGard style round door. Also covered are: Bolt shear, side punching, drilling false gates, finding Dog Pins, 'blowing bolts' and drilling perfect scope holes. It's all here. All in one book. More ways to open more lift out doors than you ever thought possible. Over 100 specific photographs. Fifty clear illustrations. Dozens of specific drill points and a special and a special drill point locator, over 140 pages. Available in two formats, book or CD-ROM. Included are drill points for Diebold, Migh-T-Safe, Kingdom, Sentry, In-A-Floor and other round heads. Page after page, illustration after illustration — all designed to help make you money.





## 1 Cores: Small Format

CD VERSION Item #ICSF-CD1 • \$55.00

PRINT VERSION Item #ICSF-1 • \$55.00

CD COMBO Item #CORES-CD • \$99.00

PRINT COMBO Item #CORES-2 • \$99.00

Everything you ever need to know about how to sell, service, install and troubleshoot interchangeable cores! Chapters include: terminology, blanks, tools, removing cores from stubborn shells, decoding cores, pinning, record keeping, installing, planning a system, masterkeying, billing and pricing tips for success. You'll even receive a final exam to help and test your knowledge! This volume contains over 140 pages of priceless information, designed to make IC core work quick, easy and profitable! Available in two formats, book or CD-ROM.



## Removable Cores: Large Format

CD VERSION Item #RCLF-CD1 • \$55.00

PRINT VERSION Item #RCLF-1 • \$55.00

CD COMBO Item #CORES-CD • \$99.00

PRINT COMBO Item #CORES-2 • \$99.00

"Removable Cores: Large Format" is packed with exploded views, photos, line art and various graphics, which will blow you away! Why worry about Sargent, Kaba, Schlage, CorbinRusswin, Medeco or Yale again? Get this book and have an up-to-date resource at your fingertips. Within its covers are a multitude of pictures, charts, drawings, exploded views, diagrams, line art, clipart, comments, etc. that will aid the reader in understanding and in solving individual RC problems on your job site.



## The National Locksmith Guide to Motorcycles Volumes 1, 2, 3 & 4

Vol. 1 CD #MOT-CD • \$99.00

Vol. 2 CD #MOT-CD2 • \$99.00

Vol. 3 CD #MOT-CD3 • \$99.00

Vol. 4 CD #MOT-CD4 • \$99.00

Any 2 on CD #MOT-CD13 • \$149.00

Any 3 on CD #MOT-CD13 • \$199.00

All 4 on CD #MOT-CD11 • \$249.00

Vol. 1 PRINT #MOT-1 • \$99.00

Vol. 2 PRINT #MOT-2 • \$99.00

Vol. 3 PRINT #MOT-3 • \$99.00

Vol. 4 PRINT #MOT-4 • \$99.00

Any 2 in PRINT #MOT-13 • \$149.00

Any 3 in PRINT #MOT-12 • \$199.00

All 4 in PRINT #MOT-11 • \$249.00

For years locksmiths have begged for a comprehensive service manuals on motorcycles, and they are finally here! Covering a wide range of service procedures, you'll know everything a locksmith needs to know about each cycle. Plus, you'll get step by step photographs and instructions. Both volumes available in two formats, book or CD-ROM. Special pricing if you order both. If you have ever been frustrated by cycles made by the following manufacturers, you'll need these comprehensive books: • Aprilia • BMW • Buell • Ducati • Givi • Harley-Davidson • Honda • Kawasaki • Malaguti • Motoguzzi • Neiman • Suzuki • Triumph • Yamaha • Zodi

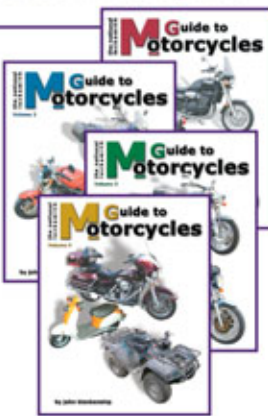

## Locksmith Dispatcher 2004

Item #DISP2004 • \$750.00

Controlled Service dispatching software specifically for the locksmith.

Features: • Easy service call entry. • 1 hour warning and late alerts. • Advertising tracking. • Employee callback tracking. • Customer callback tracking. • Plus many other money making features! • Available with or without complete Accounting module. (Accounting module includes POS, and everything else you need!)



## Cards & Keys

Item #CK-1 • \$149.00

Key blank cross reference & Code card production.

The first section of the program features a highly comprehensive database of key-blank reference numbers from 34 different manufacturers, 70,000 keys all cross indexed. This section of the program allows you to enter a key-blank reference number from a particular manufacturer and have this instantly converted to be the reference number of the brand of key-blank you use.

Print your own Code Cards with:

- Card Number • Space and Depth measurements in Metric or Imperial • Code series information (where applicable) • Cutter number • Key-blank number • Graphical representation of the key position in the jaw (allows easy positioning, and prevents mistakes) • Space & depth reference marks for needles.

The program comes pre-loaded with well over 700 cards, and also includes the ability to make your own cards should you require. Creates Punch Machine cards too!

Cards & Keys software includes BOTH card making ability and Key Companion software.

If you own InstaCode this module is already included.



## Key Companion

Item #KC-1 • \$99.00

"What is that key-blank?" How often have you wasted time trying to work out a comparison from an old or obsolete key-blank? With Key Companion, you can perform key comparisons in a snap! And also you can just identify a key if you are not sure, as a visual, then Key Companion will make the comparison for you against that selection.

This easy to use program has been designed for any key cutting operation, and allows you to compare key-blank reference numbers from 34 manufacturers in a matter of seconds, on 70,000 blanks.

Key Companion is economical, easy to install and works with all versions of Microsoft Windows. Best of all, the program includes not only 70,000 key-blank cross references, but a picture of the blank and profiles as well so you can make sure your search has produced the correct result!

If you own InstaCode this module is already included.



## AutoSmart Advisor

Item #ASA-2002 • \$295.00

New features: Now updated to include the new models. Parts Locator... do reverse searches. Enter a part number and a list of vehicles appears organized by make, model and year. Color photos of parts... the Parts Locator not only shows you all the data, but also a color photo of the part. Service Help... now on selected models full service article with color photos and step by step instructions walk you completely through every job you might do on the car. Additional updates will contain ever more service articles and models.

AutoSmart Advisor™ software tells you every scrap of information about the vehicle, all parts, costs, labor times, calculates your charges automatically, and shows you how to do the job!

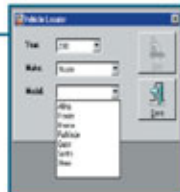

## How To Jumpstart Your Locksmith Business or Ten Ways To Increase Your Shekel Intake

Item #JUMPSTART • \$19.95

Anyone who's ever read anything that Jake Jakubowski has written is familiar with his style... A little bit of humor, a little bit of "down home" wisdom and a whole lot chutzpah. This book is just as witty, wry and pointed as everything else he had written. There's something in this book for the newbie, the seasoned 'smith and the person that's dreaming of the day when they can go out their own. "How To Jump Start Your Locksmith Business" is vintage Jake. His advice on money making, building your business and customer relations is timeless... At \$19.95, this CD version of Jake's newest book makes it one you can't afford to be without!



Item #	Title	Qty.	Price
	Shipping inside the Continental U.S.		\$8.00
	Shipping outside the Continental U.S.		\$20.00
GRAND TOTAL Paid in U.S. Funds			

Select payment method:  Check  VISA  MasterCard  Discover  American Express

Card #: \_\_\_\_\_ Exp. Date: \_\_\_\_\_

Signature (required): \_\_\_\_\_

Name: \_\_\_\_\_

Phone: \_\_\_\_\_

Shop Name: \_\_\_\_\_

E-mail (optional): \_\_\_\_\_

Address (no PO boxes): \_\_\_\_\_

Please include \$8 for shipping and handling. Orders outside the continental US include \$20 for shipping and handling. All orders must be paid in US funds.

City: \_\_\_\_\_

Copy or clip this coupon and send with payment to:

State/Zip: \_\_\_\_\_

The National Locksmith, P.O. Box 77-97592 Chicago, IL 60678-7592  
Phone (630) 837-2044 • FAX Your Order To (630) 837-1210



# PRO-LOK®

## Car Opening

## Exposed

Examples from "The Best Damn Car Opening Manual Period!"



45° counter-clockwise and position the tip of the electric lock-unlock button to unlock the door. (Photo 4)

©2002 PRO-LOK® CAR OPENING

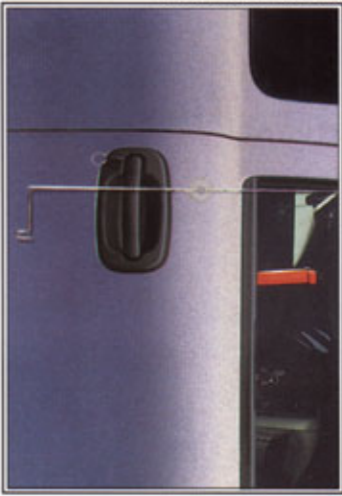
**PREFERRED OPENING METHOD**

This model was originally the C/K 1500, 2500, 3500 Pickup. Renamed Silverado in 1999. This model opens the same as the GMC Sierra.

1. Insert a wedge at 7" from the rear edge of the window glass of the passenger door.
2. Insert an Inspection light and identify the 2 angled horizontal rods located directly in front of the latch.
3. Insert the long end of an AO39 "Double Slide Tool" at the extreme rear edge of the window glass, tip facing forward. (Photo 2)
4. Lower the AO39 14" into the door cavity. Rotate the tool 75° counter-clockwise. Lift the tip of the tool under the sharp bend in the upper, more angled horizontal rod. Twist the tool to bind the rod. (Photo 3)
5. Slide the horizontal rod forward to unlock the door.

**ALTERNATE OPENING METHOD**

1. Insert a Pump Wedge at 16" from the front edge of the window glass of the front passenger door. Inflate wedge.
2. Insert an AO34 "MCOT-Narrow Tool" at 14" from the front edge of the window glass, tip facing forward.
3. Lower the AO34 14" into the door cavity and rotate it beneath the bottom edge of the window glass. Deflate wedge.
4. Lift the tool, gradually working the tip of the tool into the vehicle interior. Rotate the tool
5. Push down on the right side of the electric lock-unlock button to unlock the door.



**Silverado 01**

**YEAR:** 1999 -

**LINKAGE:** HORIZONTAL

**PICK:** CCW

**TOOL:** AO-39

"Double Slide Tool"

**CHEVROLET**



MAZDA

**Miata 02**

YEAR: 1999 – 2000

LINKAGE: VERTICAL

PICK: CW

TOOL: AO-38

"Honda Tool"



**PREFERRED OPENING METHOD**

This model was redesigned in 1999. There was no 1998 production model (gap year).

1. Insert a wedge at 8" from the rear edge of the door frame of the front passenger door.
  2. Insert an inspection light into the door cavity and identify the vertical rod located below the interior door lock button.
  3. Insert the small hook end of an AO38 "Honda Tool" into the door cavity at 4" from the rear edge of the door frame, lip facing forward. (Photo 2)
  4. Lower the AO38 10" into the door cavity. Rotate the tool 45° counter-clockwise and lift the tool to seat the tip of the tool on the vertical rod.
- When you contact the vertical rod, you will see button movement. Twist the tool to bind the rod. (Photo 3)
5. Lift the vertical rod gently to unlock the door.



©2002 PRO-LOK® CAR OPENING



**ALTERNATE OPENING METHOD**

1. Insert a Pump Wedge at 5" from the top edge of the window glass of the front passenger door. Inflate wedge.
2. Insert an AO42-SL "Tool Sleeve" at the top edge of the window glass. Insert the "1" end of an AO42 "Long Reach Tool" into the tool sleeve, lip facing down.
3. Reach the AO42 27" into the vehicle interior to the passenger door lock-unlock button. Rotate the tip of the tool to the 3 o'clock position. Seat the tip of the tool in front of the lock-unlock button. (Photo 4)
4. Pull the lock-unlock button rearward to unlock the door.



TOYOTA

**Tercel 03**

YEAR: 1995 – 1998

LINKAGE: VERTICAL

PICK: CCW

TOOL: AO-38

"Honda Tool"



**PREFERRED OPENING METHOD**

This model was redesigned in 1995, discontinued in 1999, replaced by the Echo.

1. Insert a wedge at 10" from the rear edge of the door frame of the front passenger door.
2. Insert an inspection light into the door cavity and identify the plastic tube covered vertical rod located below the interior button head.
3. Insert the small hooked end of an AO38 "Honda Tool" at 6" from the rear edge of the door frame, lip facing forward. (Photo 2)
4. Lower the AO38 11" into the door cavity. Rotate the tool 135° counter-clockwise and lift the tool to position the tip of the tool under the vertical rod at the bottom edge where the tubing stops. (Photo 3)
5. Lift the vertical rod to unlock the door.



©2002 PRO-LOK® CAR OPENING

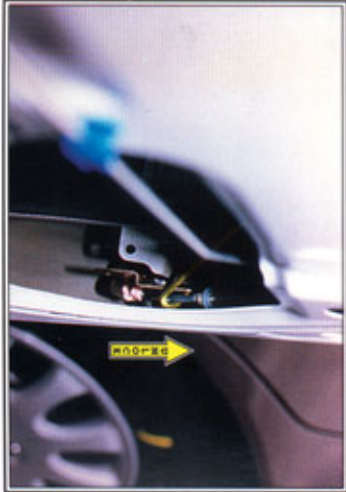

**ALTERNATE OPENING METHOD**

1. Insert a wedge at 12" from the front edge of the door frame of the rear passenger door.
2. Insert an AO37 "MCOT-Button Finger Tool" at 4" from the front edge of the door frame, lip facing forward.
3. Lower the AO37 into the door cavity. Rotate the tool beneath the bottom edge of the window glass. Remove wedge.
4. Lift the tool, gradually working the tip of the tool into the vehicle interior. Rotate the tip 30° counter-clockwise and position the tip of the tool at the upper edge of the detent in the vertical button head. Twist the tool to bind the button head. (Photo 4)
5. Lift the button head slowly to unlock the door.





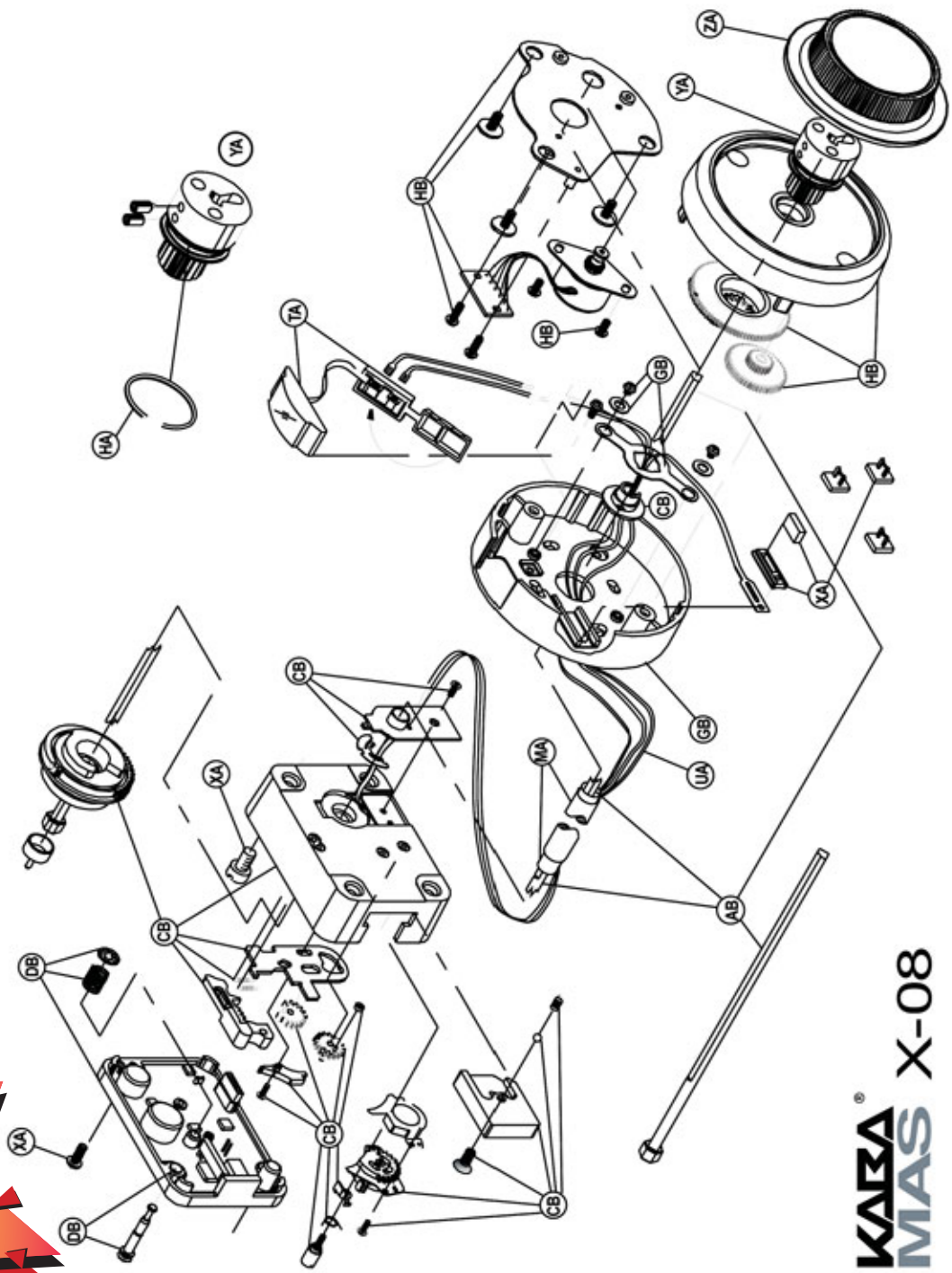

**KABA**  
**MAS X-08**

**EXPLODED  
VIEW**



# Better from start...



## The rich, lustrous brass

finish on our MK Series locksets and E Series deadbolts combines exceptional beauty with superior resistance to mechanical wear and the elements. It's the result of a special powder-coat process—an instantly visible dividend from the investment we've made in new manufacturing facilities.

Look beneath the surface and you'll find more innovations,

along with quality materials and the solid engineering that distinguishes every Arrow product.

Designed better, and priced right—it's no accident that Arrow locksets and deadbolts are the preferred brand for retrofit and new installation.

See your distributor to learn more about Arrow products and our continuing commitment to you, the locksmith.



© 2004 Arrow Lock & Door Hardware • 325 Duffy Ave • Hicksville, NY 11801 • Phone: (516) 704-2700 • Fax: 1-(877)-228-6480 • [www.arrowlock.com](http://www.arrowlock.com)

An ASSA ABLOY Group company

ASSA ABLOY

Circle 354 on Rapid Reply

X-08 Lock Case Assembly, Std. Bolt no cover, with loose flush bolt 501012

**CB**

1. Cover Baffle
2. Cam ASM
3. Case Sub ASM
4. Rack Sp. 3T, 32P
5. Screw - PH, 1/62 X .188
6. Slide Retainer
7. Gear SPL, 11T (18T), 32P Rack Drive
8. Gear SPL, 16T, 32P Slide Dr
9. Roller, .146 OD X .063 ID X .064
10. Extension Spring
11. Slide ASM
12. Bolt Detent Ball
13. Bolt Detent Spring, SPL
14. Screw - Bolt, FH 8 - 32X .375 Hex SOC.

15. Std. Bolt
16. Flush Bolt, Loose
- \*17. Motor/Gear Plate ASM
- \*18. Motor/Gear Fence
- \*19. Gear Gaurd Bracket
- \*20. Screw - PH 2 - 56 X .25
- \*21. Torsion Spring
- \*22. Screw - 2 - 56 shoulder special
23. Ground Contact
24. Tube Retainer
25. Screw - FH 2 - 56 X .188 TORX, UC

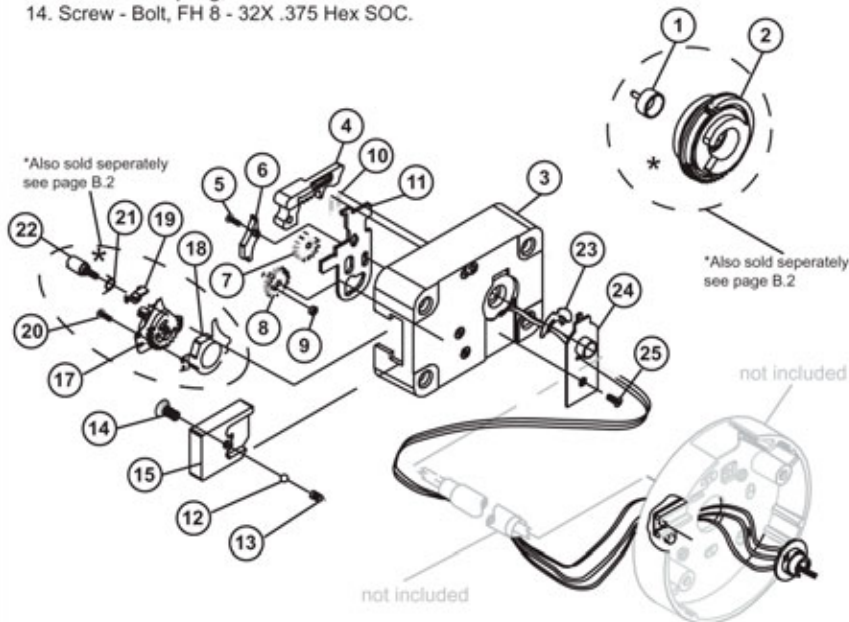

X-08 4.5" Spindle Assembly 501009  
Spindle ASM, W-THK 4.5  
Cover Baffle

**AB**

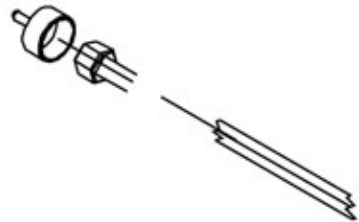

X-08 Hub Assembly 504060

**YA**

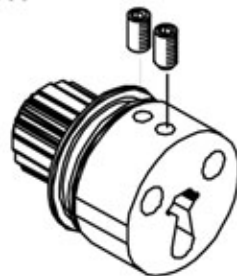

X-08 LCD Assembly 507070

**TA**



X-08 Back Cover Assembly 501003

- Cover ASM, X-08  
Cover Lock Pin  
Retainer Ring, E. Type, 5/32 Dia. Shaft  
Special Compression Spring  
Screw - PH 6-32 X 5/16

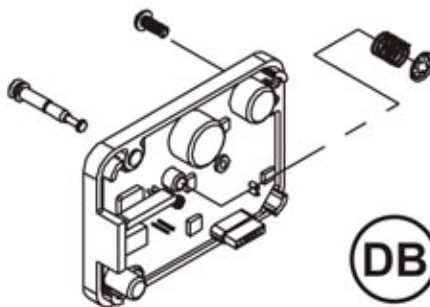

**DB**

X-08 Motor Kit 507072

- Gear/Motor Plate ASM  
Motor/Gear Fence  
Gear Gaurd Bracket  
Screw - 2 -56 Shoulder, Special (Gear Stop)  
Torsion Spring  
Screw - PH 2 -56 X .25

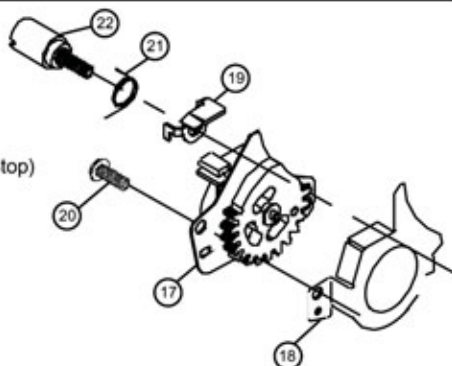

X-08 Drive Cam Assembly 501007



**KABA**<sup>®</sup>  
**MAS** X-08



X-08 Dial Ring Cover Assembly 501006

Dial Ring Cover ASM  
Screw - SEMS, 6 -32 X .313, Plain

HB

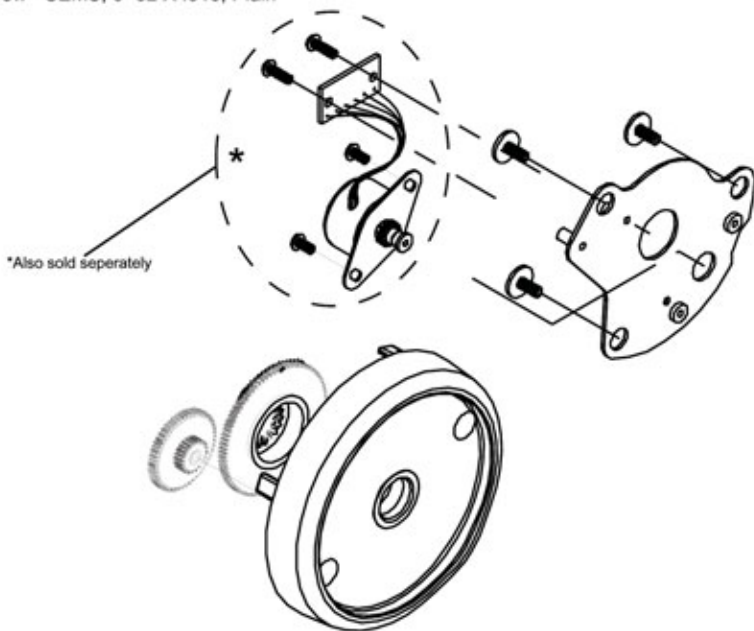

X-08 Tube Kit 104017

Inner Tube 4.5  
Outer Tube 4.5

MA

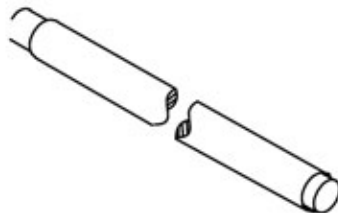

X-08 Dial 504061

ZA



X-08 Cable Assembly 507071

Cable ASM, Flex Wall Thk. 4.5  
Ground Contact  
Tube Retainer  
Screw - FH 2-56 X .188, TORX, UC

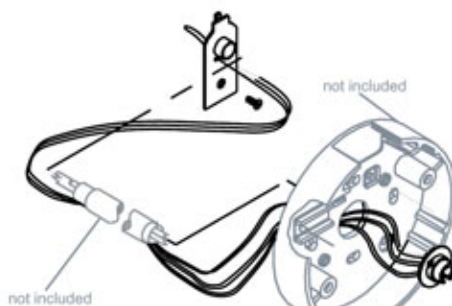

X-08 Change Key 107061

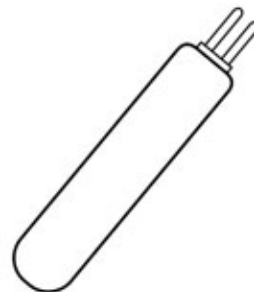

X-08 Dial Ring Assembly (no LCD) 501005

Dial Ring  
Spindle Tube Retainer  
Spindle Tube Holder  
Screw - BH, 4-40 X .153, Comb. Drive  
Washer, SPL. Flat, .185 ID X .360 OD

GB

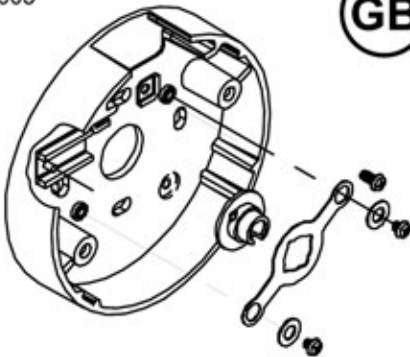

X-08 Generator 501018

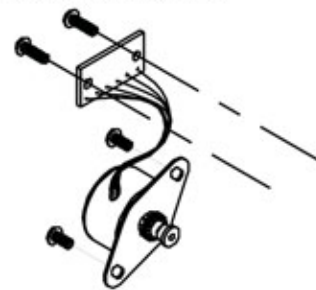

**KABA**  
**MAS** X-08

# Door Jack Sets



**GLOWS IN THE DARK!**

**Patent Pending  
Scratch Free Shielding!**

Both The Lightning Rod™ and the Shielded Quick Max™ Glow In the dark and have a unique patent pending Scratch Free Shield



**Shielded Quick Max Tool™**  
Nylon Case Remote Control Super Strap Tool  
One Hand Jack Special Stiff Insert Makes Insertion Easy

One Hand Jack Set: Includes Shielded Quick Max Long Reach Tool, Air Jack Air Wedge, Super Strap Tool, Carrying Case #OHJS4 \$59.95



**Lightning Rod™**  
Remote Control Super Strap Tool  
Patent Pending One Hand Jack Rubber wedge

Lightning Rod™ Kit: Lightning Rod™ Long Reach Tool, One Hand Jack Tool, Rubber Wedge, Super Strap Tool #LRK \$59.95  
Lightning Rod™ Kit: With Air Wedge #LRKAW \$79.95

**Lightning Rod™**

**Now Only \$39.95**

Patent Pending  
Sure Grip Handle



Special Sleeve won't Scratch the car door!

Removable L.E.D. Tip

The Lightning Rod™ is the Long Reach Tool of the Future. With its Unique removable L.E.D. Tip, Glow in the dark Shielded cover that won't scratch the vehicle, Sure Grip Handle for better control, and New Low Price.

**1-800-323-8324**



# Upgrade Any Brand Car Opening Tools to the High Tech Tools Professional Grade Vehicle Access System



**Unlock Cars from 1979 To Present!**

For a limited time, upgrade Any Brand of car opening tools, to the new 2004-2005 Professional Grade Tools from High Tech. This Offer is good on Any Brand of tools, regardless of the manufacturer.

*Here's how it works. Just give us call and tell us what brand tools you currently use, you don't have to send them to us. When you upgrade, we will send you our 1600 page two volume opening manuals, and our tools. Prices start at just \$79.00. This is offer may not be combined with any other sale offer or coupon. Valid only for new customers, not valid for any previous purchase. This is a limited time offer!*

**100% Money back Guarantee**



The High Tech Tools Vehicle Access system, gives you the specialized tools you need, with step by step photo instructions. The only system in the world, that includes every modern auto lock-out technique, and innovation in one easy to use set. Auto and Truck Lock-outs are our Business, Our Only Business!

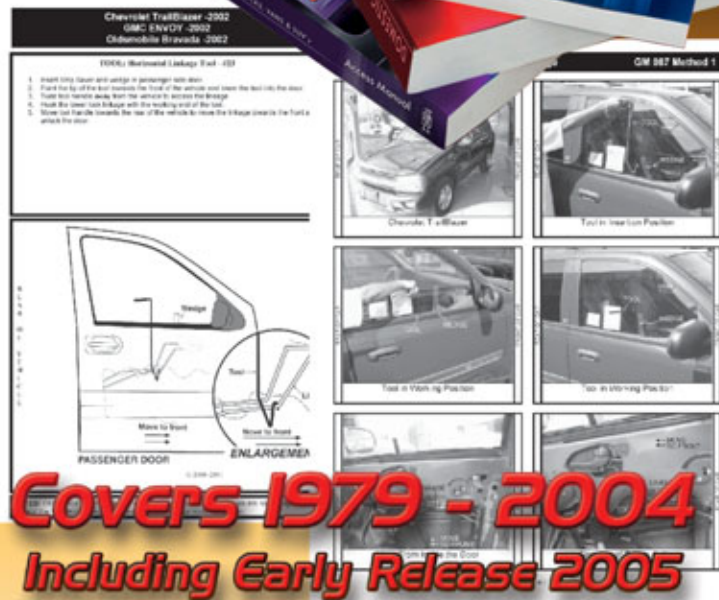

**Covers 1979 - 2004  
Including Early Release 2005**

**HIGH TECH TOOLS**  
**1-800-323-8324**

High Tech Tools • 1628 NW 28th Street • Miami, FL 33142 • 305-635-1011 • [www.hightechnools.com](http://www.hightechnools.com)



A couple of years ago, in a meeting at HPC, a decision was made to build the best code machine in the industry. The room was full of creative people, engineers, draftsman, mechanical and computer experts, some with over twenty years of experience in the industry. Everyone had an opinion on what the machine should be able to do. But, how do you determine what "The Best" really means? So the question was taken to the street. Locksmiths were asked.

Locksmiths were telephoned, talked to at tradeshow, and were gathered together in focus groups. All this to determine

1. The HPC Blue SHARK™.



what locksmiths wanted and needed in the ultimate computerized code machine.

This journey led to the development of the Blue SHARK™ (see photograph 1).

The number one necessity for all the locksmiths was accuracy. Everyone agreed that the machine had to be accurate, but it was taken a step further. The user needed to be able to calibrate and fine-tune their machine to .0005". The Blue SHARK™ has a self-calibration system that electronically determines the distance between the jaw and the cutter and confirms and/or corrects depths, shoulder spacing, tip spacing, and even tip-to-bow measurements. The Blue SHARK™ also gives the user the ability to override the self-calibration results and make DSD specific or overall

machine adjustments. These features allow the operator to easily set an individual machine to their exact requirements.

After accuracy, it was unanimous that the Blue SHARK™ had to be easy to use. Too many times complex machines have confusing controls, multiple buttons that have to be pressed in the right sequence, and long lists of alpha-numeric codes that need to be entered in order to do the simplest of tasks. What good would a multi-functioned machine be, if you had to continuously refer back to the manual? The Blue SHARK™ had to be the easiest code machine to operate. Adding a touch screen with a graphical user interface solved this problem. For the first time ever, true advanced computer controls were added to a key machine. A graphic-intensive touch screen allows users to clearly, quickly, and easily jump from one screen to another and find everything they need.

The Blue SHARK™ is loaded with depth and space information

THE  
EVOLUTION  
OF THE

Blue SHARK™





▲ **2. The easy to use touch screen interface.**

for over 800 manufacturer lock specifications that you can easily search through by name or HPC DSD (Depth & Space Data) number. On the opening screen there are shortcut buttons that allow the user to get cutting information on specific keys fast. These are called "presets", where the user presets their top-three most popular keys, so with a simple click of the button they are ready to start entering a bitting. This feature was at the top of many locksmiths' wish list. There is

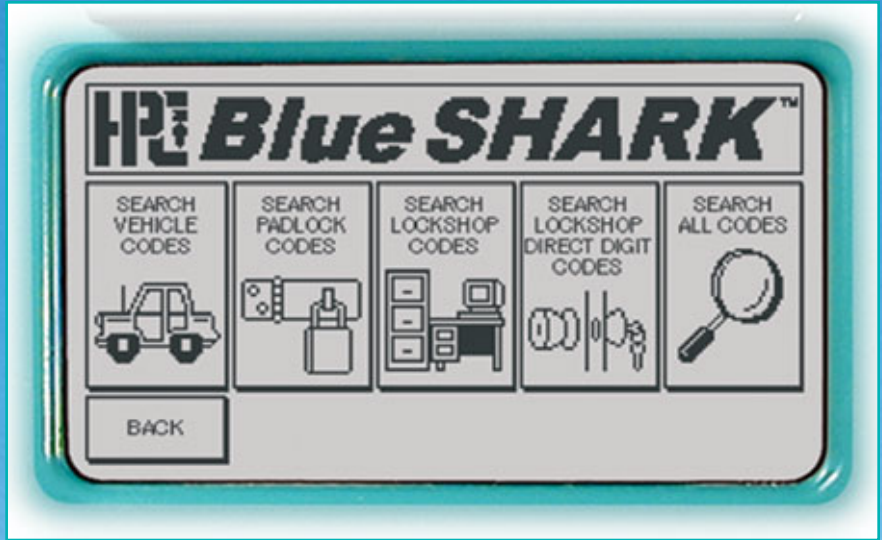

▲ **3. The code options.**

also another button that displays the last key that was cut. This allows you to jump right back into the last job you were working on (see photograph 2).

"The ultimate computerized code machine should have codes inside," was another recurring statement from the locksmith

industry. But not just automotive codes, all codes needed to be readily accessible. So the entire CodeSource® database of cuttable keys was added, broken down into four sections; Vehicle, Padlock, Lockshop, and Lockshop Direct Digit codes. A bitting can be found when searching by code, manufacturer,



**SAFE CORPORATION**  
**LARGEST DEPOSITORIES IN THE INDUSTRY**

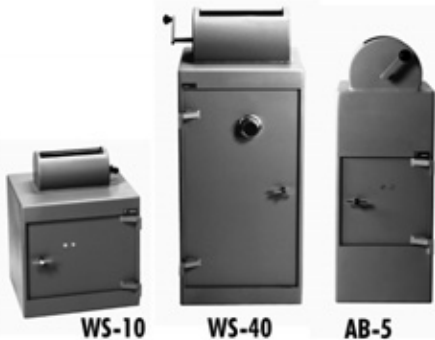

WS-10

WS-40

AB-5

171 S. Delsea Drive  
 Glassboro, NJ 08066

800-253-1267  
 856-863-1186  
 Fax 856-863-1208

**Visible Key Control**

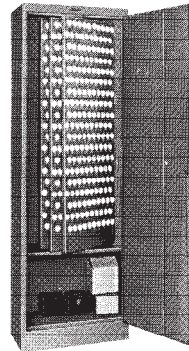

Floor Key Cabinet  
 760-2280 capacity

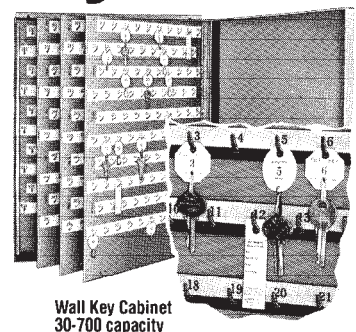

Wall Key Cabinet  
 30-700 capacity

**Low-Cost, Simplified**

- Visual inventory of keys and tags.
- Plastic color tags available for color coding areas.
- Illustrated instructions for easy installation.
- Single or dual tag systems.
- Improves security, reduces key loss.
- Choose from 75 standard cabinets

[www.lundkeycab.net](http://www.lundkeycab.net)

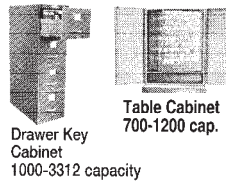

Table Cabinet  
 700-1200 cap.  
 Drawer Key Cabinet  
 1000-3312 capacity



Badge Cabinet To  
 168 badges



Portable Case  
 56 capacity



Mini-Wall  
 10-20 capacity



Key Tray  
 56 cap.

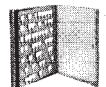

Big Head Keys  
 40-350 cap.

**LUND EQUIPMENT CO., INC. Dept. NL**  
 P.O. Box 213, Bath, Ohio 44210  
 Cleveland Tel. 330/659-4800

Key systems for over 60 years FAX 330/659-9347





▲ 4. The update card.



▲ 5. The 4-way jaws and popular keys.

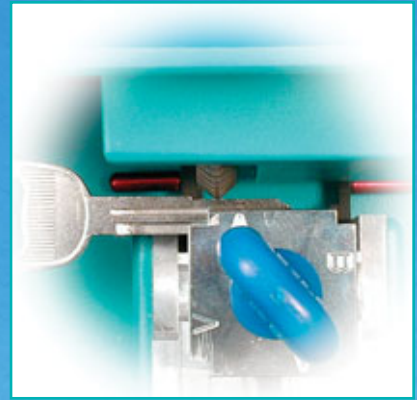

▲ 6. Electronic touch-off.



▲ 7. The added convenience and safety features.



◀ 8. The help file.

or key blank. Again, the idea was taken a little further and a key blank cross-reference was added to help the user do their job even faster (see *photograph 3*).

By adding all of these features into the machine, the locksmiths next concern was answered; they wanted a stand-alone machine, a computerized code machine that did not have to be hooked up to a computer. But, what about updating? What happens when more codes and new features become available? Everyone wanted a machine that could be updated easily with or without the use of a computer. So two different ways to update the Blue SHARK™ were created. One way is via CD with a Windows® based PC. The other is a computer-free method using a multi-media card inserted into the back of the Blue SHARK™. Simply insert the update card (see *photograph 4*) press the update button on the

screen and the Blue SHARK™ takes care of the rest.

Along with making the Blue SHARK™ easy and fun to use, many other great features were added that allow it to cut a wide variety of different keys. The first of these features was a newly developed 4-way jaw that mimics HPC's time-tested Blitz® 2-way jaw with the addition of two more specially designed sides. The Blue SHARK™ Cut Screen clearly shows the user which side of the jaw to use based on the key they are about to cut. With this new jaw and the electronic touch-off fea-

ture, cutting double-sided keys accurately becomes extremely easy to do. The electronic touch-off system momentarily determines the position of the key before it starts cutting so you get accurate cuts time after time.

The Blue SHARK™ offers 5 different cut styles. The Plunge Cut is the default setting for the Blue SHARK™. This is a standard cut that plunges the blank straight into and out of the cutter. The Contour Cut eliminates the peaks between cuts while retaining the manufacturer's specified angles.



The Smooth Cut glides over the blade leaving all cut roots intact and creating new angles to make the smoothest key possible. The Contour Barb and Smooth Barb Cuts leave the tip peaks intact to aid in key retention. Lastly the Blue SHARK™ can automatically make high-security angle cuts, and with adapters can even cut Tibbe and standard tubular blanks (see photograph 5).

One of the features that separates the Blue SHARK™ from all the rest is custom DSDs is the ability to add in your own custom depth and space data. This feature really takes a giant leap for code machines by giving users the ability to program their own data into the machine. It is ideal for restricted keys that have contract-protected depth and space data. Another request was to have the Blue SHARK™ duplicate keys. Since duplicating is a less accurate method of cutting keys, the Blue SHARK™ did one better.

A precise decoding feature was added. Using the electronic touch-off and the included decoder plate, the Blue SHARK™ can read an existing key, determine if it is worn or not, and give the proper manufacturer depths so you can cut a new factory original instead of duplicating a badly worn key (see photograph 6).

Everyone loved the idea of being able to have such intricate control over the machine, but the fear was that too many people would have access to make changes. So an optional security feature was built in that allows all users to cut keys, but only the password holder to make adjustments.

The Blue SHARK™ was finished with a rightfully deserved futuristic design featuring a flexible light in the cutting area for greater visibility and the new HPC Quick Nut for changing cutters without tools (see photograph 7). A removable safety

shield and concealed deburring brush were added for safety. And to make sure the machine was extremely easy to use a full on-line help file was added to complete the extensive list of features (see photograph 8).

Finally, registered owners of a Blue SHARK™ can choose to receive a copy of HPC MasterKing® or KeyTrail® as a free gift. Bittings from both of these programs download to the Blue SHARK™ creating a complete key management system.

The Blue SHARK™ was received with rave reviews when it was first introduced over one year ago and more and more locksmiths list the HPC Blue SHARK™ as their go-to machine.

For more information contact: HPC, Inc., Phone: 800-323-3295 or (847) 671-6280; Fax: (847) 671-6343; E Mail: [hpc@hpcworld.com](mailto:hpc@hpcworld.com); Web: [www.hpcworld.com](http://www.hpcworld.com). Circle 353 on Rapid Reply. 

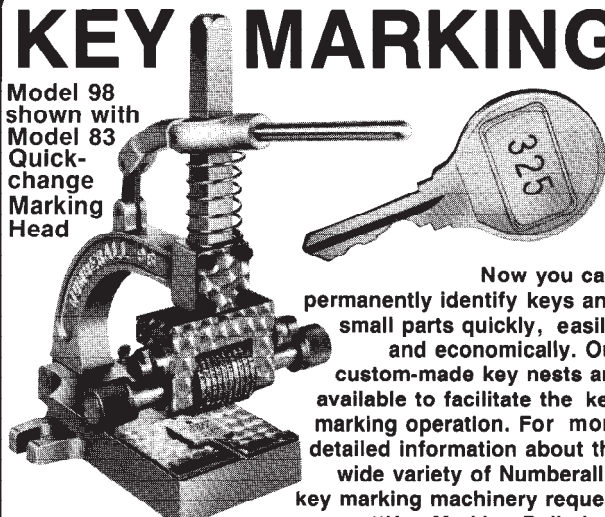

# KEY MARKING



Model 98 shown with Model 83 Quick-change Marking Head

Now you can permanently identify keys and small parts quickly, easily, and economically. Our custom-made key nests are available to facilitate the key marking operation. For more detailed information about the wide variety of Numberall's key marking machinery request our "Key Marking Bulletin."

**A WIDE ASSORTMENT OF MARKING TOOLS FIT THE MODEL 98 PLATFORM PRESS**

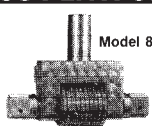
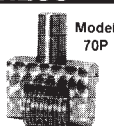
Model 23P Typeholder    Steel Type    Model 85P 2 wheels quick-change    Model 70P Multi-wheel

Since 1930 NUMBERALL has been manufacturing and servicing a complete line of American-made marking equipment. Write or call for our complete catalog.

**NUMBERALL**

CALL THE COST OF STAMPING EQUIPMENT

**NUMBERALL STAMP & TOOL CO., INC.**  
 BOX 187, HIGH ST., SANGERVILLE, ME 04479

(207) 876-3541  
 FAX (207) 876-3566

Circle 260 on Rapid Reply

## WE STOCK MARKS, MARKS AND MORE MARKS.



**MAYFLOWER**

800-221-2052 [www.mfsales.com](http://www.mfsales.com)

INMETRONYC/718-622-8785 FAX/718-789-8346 EMAIL/[pilgrim@mfsales.com](mailto:pilgrim@mfsales.com)

ASK FOR YOUR FREE COPY OF OUR NEW CATALOG.

Circle 252 on Rapid Reply

July 2004 • 61

# ASSA

# CLIQ™



by  
**Sal Dulcamaro,**  
**CML**

**A**SSA is introducing electromechanical lock cylinders that use what they call “CLIQ” technology (see figure

1). Electronic

access control with time restricted access and audit capability will be possible with the mere switching out of the lock cylinder itself. There will be no need to replace the existing (strictly mechanical) door hardware with new electronically enhanced door hardware, because the electronics will be completely contained within the keys and lock cylinder plugs. While electromechanical lock cylinders will not be low priced; you will have dramatically increased flexibility and ultimately lower costs. There won't be the need to modify door preps to accommodate the additional mounting holes generally required by electronically enhanced locksets. If lock requirements change, there won't be the need to patch or cover holes in doors where electronic locks are removed and then re-drill the new doors that will take those locks. Locks

will be able to be converted as quickly as you would otherwise switch out regular mechanical lock cylinders.

## CLIQ Technology

CLIQ technology, as I have heard it, was originally developed and used in Europe using larger sized lock cylinders. The first version (modified) ASSA mortise cylinders that used the CLIQ

technology in the U.S. market were 1-3/8” to fit the electronic components within the confines of the cylinder plug. Those electronic components are being reduced in size to fit in the more conventional sized lock cylinders. CLIQ technology now fits into the 1-1/8” length mortise/rim cylinders, knob/lever cylinders and others.

It is built off of the platform of the ASSA Twin mechanical lock and key system and adds electronic components to increase both the capabilities and security of the lock cylinders. Among its beneficial features are:

- Audit Trail with Date & Time
- Time Zoning
- Ease of Installation
- No Wires
- Can Use Existing Door Prep
- Power Supply is Provided by the Key
  - Data Transfer 64 Bit and Higher
  - Can Be Tied Into Existing Twin Pro Master Key Systems
- Battery Life 2 Years or 20K Openings
- Lifetime on Key Breakage



1. ASSA CLIQ.

**Continued on page 64**



# HPC Hot Summer Savings!



EPG-1

## Original Electropick™

Special Suggested Dealer

~~\$141.00~~ **\$120.00**

All Models on Sale!



IPIN-99

## Illuminated Pinning Station

Special Suggested Dealer

~~\$125.00~~ **\$117.00**



LHR-100

## Lever Handle Remover

Special Suggested Dealer

~~\$210.00~~ **\$189.00**



HDPS-4

## Double D Punch

Special Suggested Dealer

~~\$131.00~~ **\$122.00**



USA-10

## American Flag Pick Set

Special Suggested Dealer

~~\$33.95~~ **\$29.00**

## Bi-Fold Wallet Pick Set

Special Suggested Dealer

~~\$45.00~~ **\$39.00**

BFW-8

## Tr-fold Wallet Pick Set

Special Suggested Dealer

~~\$45.00~~ **\$39.00**



TFW-5



CO-80

## Switch Stick™

Special Suggested Dealer

~~\$38.95~~ **\$35.00**

## Original Air Wedge™

Special Suggested Dealer

~~\$28.95~~ **\$24.00**

## Universal Air Wedge™

Special Suggested Dealer

~~\$33.60~~ **\$28.00**



AW-99

AW-100



HPC, Inc.  
3999 N. 25th Avenue  
Schiller Park, IL 60176 USA  
Tel: 847.671.6280  
Fax: 847.671.6343  
www.hpeworld.com

All pricing is in U.S. Currency. HPC Summer Specials runs through August 31, 2004

Circle 230 on Rapid Reply



2. Miniaturization of the various electronic components.



3. The ASSA CLIQ key is mechanically identical to the ASSA Twin Pro.



4. The circular outline by the key's battery.

CLIQ technology is made possible by the miniaturization of the various electronic components (see figure 2). A miniature motor, within the confines of the plug, drives the electromechanical blocking element that locks the side rail. CLIQ technology is only used with ASSA Twin Pro systems. Twin Pro is a variation of ASSA Twin Exclusive or V10. Because the lock cylinder and key are still mostly mechanical, CLIQ electronics and standard mechanical Twin Pro cylinders can be integrated within a single master key system. Master keys can operate all the locks (mechanical and electromechanical) within a single system, while keeping costs down by using mechanical cylinders where time zoning or audit aren't necessary.

The ASSA CLIQ key is mechanically identical to an ASSA Twin key—the ASSA Twin Pro, specifically (see figure 3). As such, it can be used to operate standard mechanical Twin Pro lock cylinders. The side code pattern of the key determines if a current Twin Pro assigned keyway is compatible with CLIQ technology usage. The fourth position cut must

be a 3, 4 or 5 depth. The side milling and sidebar of a CLIQ key and plug will work a bit differently than a strictly mechanical Twin Pro version. If you become a new Twin Pro dealer with the intention of using CLIQ technology, the side code will have already been specified to work within CLIQ requirements.

The electronics in the head (bow) of the CLIQ key allow for operating the CLIQ cylinder. An electronic code is programmed into a memory chip within the bow. The circular outline by the key's battery is visible on the opposite side of the CLIQ key (see figure 4). The electrical contact is on this side of the key blade. Data is transferred from the key to the electronic components within the plug and vice versa. The key bow is not much larger than for a standard mechanical system ASSA key. The battery in the key has a relatively long life, so frequent battery changing will not be too likely. Environmental conditions and frequency of use will affect battery life. There is no battery in the lock. The battery in the key powers the motor in the lock.

Continued on page 66



5. The hand-held programming unit, computer interface cables, software, CLIQ keys and cylinders.



6. Different type CLIQ keys have a different color scheme and look for the key bows.



**Bianchi 303 - High Security Automotive Key Machine**

**\$ 1,799**  
+ s&h

The Bianchi 303 duplicates high security laser and dimple type keys. The robust construction and innovative design results in an extremely durable, precise and easy to use key machine. The 303 is the tank of its class at 51lbs and the heavy casting reduces vibration resulting in less noise, longer cutter life, and better cutting tolerance.

**Free Mercedes Adaptor  
Bonus with purchase  
from  
Nat'l Auto Lock Svc**



- One-piece casting provides better tolerance and eliminates horizontal movement during cutting, common in two-piece roller guide designs.
- Micro-switch activated and semiautomatic key cutting operation.
- Large protective shield covers the entire cutting.
- Unique and safe single-mode system. Simply press the red button to calibrate and the black button to proceed with cutting.
- Electromechanical 360-degree calibration. Unlike competitive models, the horizontal depth and spacing (left to right and front to back) can be adjusted in addition to vertical depth.
- Capable of code cutting and duplicating additional lock systems using adaptors.

• We offer the largest selection of High Security Space & Depth Key Sets for originating a key.



• The widest selection of Dealer Only / Factory Keys.



The demo unit contains the hand-held programming unit, computer interface cables, software, CLIQ keys and cylinders (see figure 5). Different type CLIQ keys have a different color scheme and look for the key bows. From top to bottom they are: User Key, Distributor Key, Contact Key and Master C-Key (see figure 6). At this point, I will be very general with information, as I have not been able to get my hands on the actual product. I will go into much more technical detail in a future article.

The hand-held programming unit is the interface between the computer where the software resides and CLIQ keys and lock cylinders (see figure 7). This device is used for programming U-Keys (user keys) and CLIQ lock cylinders. Data is sent to, or retrieved from a lock cylinder through one of the data transfer keys. A Contact Key that is wired to the programming unit, can audit a lock cylinder. A C-Key can have data downloaded to it from the computer and then remotely delivered to individual lock cylinders



7. The hand-held programming unit.

without the programming unit coming along. Similarly, audit data can be remotely uploaded to a C-Key from a CLIQ cylinder and then retrieved by the computer by inserting the C-Key in the hand-held programming unit.

### CLIQ Software

CLIQ software allows you to keep track of all functions of the cylinders and keys. The Lock Chart shows the basic screen with key and cylinder information (see figure 8). The serial numbered keys are on the left and the cylinders are listed on the right. Intersecting squares indicate the status of the keys and cylinders.

The Cylinder Audit trail chart indicates the dates and times that CLIQ keys were inserted into the cylinders (see figure 9). It also indicates the action the cylinder took with the individual keys. A CLIQ cylinder will retain 1000 audit events and when that number is exceeded it will drop off the oldest event. Each CLIQ cylinder can accept up to 1000 "authorized" individual

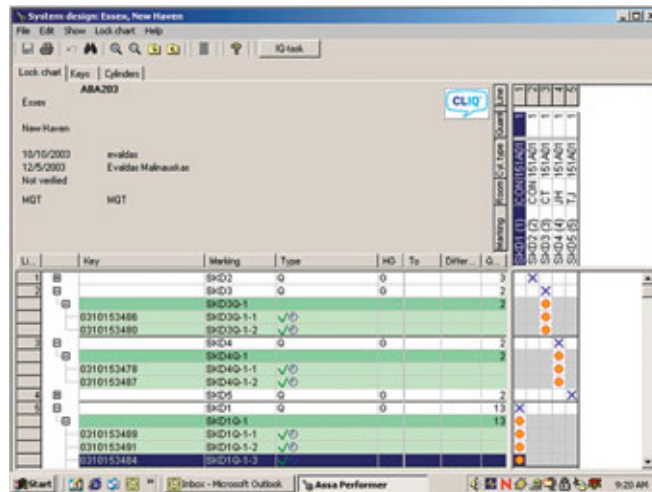

8. The Lock Chart.

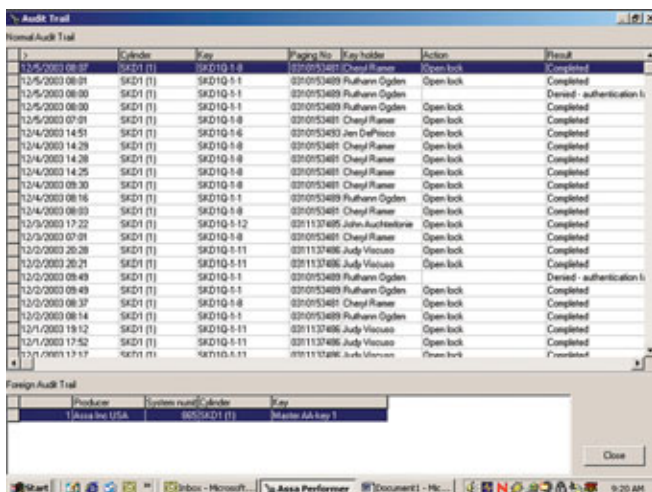

9. The Cylinder Audit trail chart.

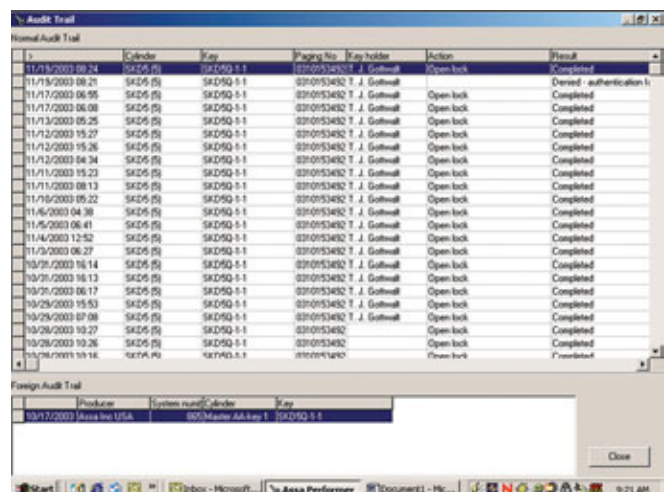

10. The Key Audit chart.



users or user groups. Similarly, the CLIQ cylinder can lock out up to 1000 "unauthorized" users. The cylinder will also keep a "Foreign Audit Trail" which means it will record attempts by CLIQ keys from any other system. The Foreign Audit Trail is limited to 10 events, and drops off the oldest event when it reaches 11.

When a CLIQ key and cylinder interact, data is exchanged and stored. Since the battery is only in the key, so is the clock. While the lock cylinder will decide which keys are authorized, the time zone restrictions for each key reside within the programming of the key. The electronic clock in the key imprints the time and date into the cylinder so it will become a usable audit event. The battery in the key powers the motor in the cylinder for unlocking, if the user is authorized and within the authorized time zone. The Key Audit chart lists the CLIQ cylinders that interacted with a particular CLIQ key (see figure 10). It will indicate the date and time of each event and the action taken by the cylinder that interacted with the key. The key also keeps a Foreign Audit Trail, which will indicate the key being tried in CLIQ cylinders outside the system.

I doubt that I have captured all of the subtleties of CLIQ technology, but I think I have given a bit of the flavor. As with anything electronic, there will likely be various refinements and improvements over time as more memory can be packed into smaller and smaller packages. Numbers of users and audit events are generally limited by data storage capabilities. Customer needs and requirements may also suggest refinements. CLIQ technology is intriguing and I expect to do a follow up future article in much greater detail. **RL**

# A Cut Above...



No matter what kind of van you have - Adrian Steel Locksmith Packages are a cut above the rest. More storage area. More work area. More isle space. It's almost like bringing your shop along wherever you go. For more information or a local distributor, call 1-800-677-2726, or visit us on the web at [www.adriansteel.com](http://www.adriansteel.com).





**ADRIAN STEEL**

**Commercial Van  
and Pickup Equipment**

Circle 205 on Rapid Reply

SCHLAGE • WEISER • ARROW • CAL-ROYAL • KWIKSET • DEXTER

**ONE CALL WILL GET YOU THIS AND MORE!!**

**1-800-848-1577**

**SCHLAGE**

If you need Schlage...Give us a call with your needs.  
We stock the popular AND hard to find items.

===== AVAILABLE AT: =====

**ZIPF LOCK COMPANY**

**P.O. BOX 935      COLUMBUS, OHIO 43223**

**1-800-848-1577(Nationwide)      1-800-228-6320 ZipFAX®**

We accept MasterCard, Visa and Discover credit cards.

CHICAGO • NATIONAL CABINET • TIMBERLINE • DETEX • HPC

Circle 281 on Rapid Reply

# SECURITRON'S

## iMXD

by Mike Cain & Aileen Dingus

**D**elayed exit, instant profit! Why is this so important? According to the retail edition of About.com, "...each year, retailers lose an estimated \$27 billion in merchandise primarily through theft..." Also, the Retail Theft Trends Report states that "discount, department, and supermarket retailers accounted for 41% of the retailers surveyed, but they represented a whopping 88% of the shoplifting cases."

What these statistics don't say is that much of retail theft takes place through under-secured doors, in areas without adequate surveillance. Most of these doors have some sort of panic hardware for immediate egress and positive latching to secure the door from outside entry. The immediate egress is what poses the problem.

Securitron has developed a product specifically aimed at retail loss, although there are other significant applications that will be discussed later. The product is the Integrated Movement Exit Delay system or iMXD. (See *photograph 1.*) While the concept of exit delay is not new, the iMXD makes choosing a system as simple as selecting the voltage.

Exit delay systems secure exit doors electronically and/or mechan-

ically while permitting routine delayed egress from within. In the past many systems were cobbled together using component parts, often from different companies, resulting in installation difficulties and compatibility issues with local and national building codes.

The iMXD system is the next level in electromagnetic exit delay systems, designed to be an all-inclusive tool for loss prevention professionals. If a thief cannot exit unnoticed or unhindered, there is less chance that theft will occur. With or without an addi-

tional alarm system the iMXD will help reduce retail shrinkage, and raise profits.

### Integrated Design

By being fully integrated into one cohesive system, and having a single model number in either 12 or 24 VDC, the flexibility of the iMXD allows the same unit to conform to all local and national building codes out of the box, without ordering special options. The iMXD operates with existing door hardware without any modifications. This makes the iMXD perfect for retrofit applications.

The iMXD system is built around Securitron's energy efficient M62SC Magnalock. (See *photograph 2.*) The M62SC has a holding force of 1,200 lbs, and comes with Securitron's patented Senstat option, which provides a lock status sensing signal which positively indicates that the door

is secure. Senstat is superior to the commonly used door position switch, which indicates only that the door is closed, but not that it is secure. Senstat reports both door position and the energy state of the magnetic lock.

What separates the iMXD from all other electromagnetic based exit



Photograph 1.



Photograph 2.

Continued on page 70



# ilco

Keyed To Quality And Locked Into Service<sup>SM</sup>

*Best Features,  
Best Value,  
Best Choice.*

# Universal II<sup>TM</sup>

The ultimate "Card Type" code machine for originating commercial, residential, and automotive keys!



**Titanium Nitride Coated Cutters**



**Wider Key Gage Design**



**Easy View Code Cards**  
(A copyrighted Ilco exclusive)



**"Dial Type" Depth Calibration**

- Popular "Card Type" design, simple to operate.
- Ready for use; supplied with 120 code cards, 2 cutters, & accessories.
- Compatible; code cards and cutters work with HPC code machines & vise versa.

**Additional Accessory Items Now Available!**

Check out our  
**NEW WEBSITE!**  
[www.kaba-ilco.com](http://www.kaba-ilco.com)

1-800-334-1381

Circle 237 on Rapid Reply



A Member of the KABA Group



delay systems is the spring-loaded sex bolt which is specifically designed to allow the door to move up to 1" [25mm] (adjustable from 1/8" to 1" [3mm to 25mm]) before going into alarm. (See photograph 3.) When the door is pushed, the spring bolt expands to keep full contact between the strike plate and the M62 Magnalock, keeping the door magnetically locked, while a reverse action returns the door to the latched condition. This is especially handy in areas where code allows a nuisance delay in case of accidental activation. The adjustable gap on the sex bolt, combined with the reverse action plunger virtually eliminates false alarms caused by changes in building pressure or "door rattling" from the outside.

The iMXD also contains all the electronics required for exit delay, including microprocessor, audible alarm, indicator lights and keyswitch for reset and/or bypass. (See photograph 4.) All that needs to be added is the

appropriate Securitron power supply. The iMXD and all of the Securitron boxed power supplies are UL listed.

All of the components of the iMXD are contained in a sturdy, stainless steel housing. (See photograph 5.) This makes the iMXD not only vandal resistant, but also attractive enough to be installed in any retail settings, where inconspicuous security is a bonus.

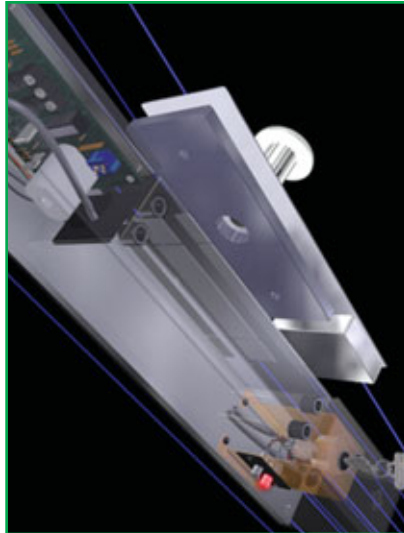

Photograph 3.

Since the iMXD is a fully integrated system, with no obvious initiate switch in an open or closed door position, tampering is eliminated, thus maintaining legal safety requirements.

As an added benefit, the iMXD is completely covered by Securitron's MagnaCare(tm) Lifetime Replacement Warranty. Simply put, MagnaCare is a lifetime replacement warranty for all Securitron branded products. It is valid regardless of the cause of failure, and Securitron will ship the replacement product out overnight at no additional cost to the client.

### When To Choose The iMXD

Exit delay systems are usually used to fight risk of loss by theft. Typical installation sites include retail stores, museums, libraries, computer and business technology centers. Without exit delay protection, a thief can move stolen goods through an alarmed

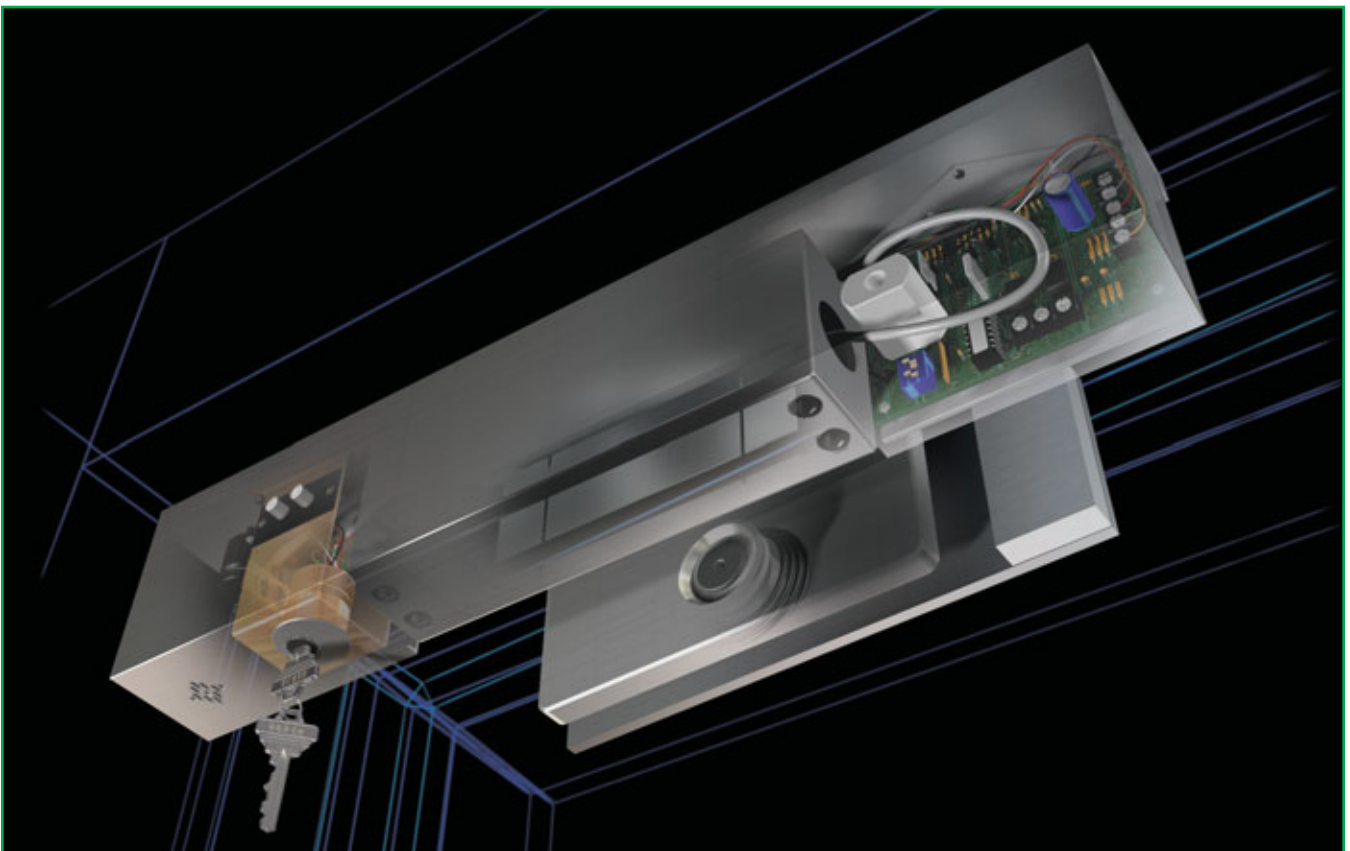

Photograph 4.





**Photograph 5.**

exit door, escaping before countermeasures can be taken. A door equipped with an iMXD system forces a thief to wait out the alarm period, enduring a 15 or 30 second alarm blast. That is sufficient time for action should the thief decide to wait at the violated door.

Delayed exit isn't just for retail however. Hospitals and nursing homes responsible for patient safety successfully employ exit delay in denying immediate egress to individuals under their supervision. Attempts at unauthorized exit by those suffering Alzheimer's, psychosis or disorientation are easily checked by an exit delay period, canceling a significant liability threat from patient endangerment, and helping ensure patient safety.

Another popular setting for exit delay is airports, government buildings, day-care facilities - or other facilities where pedestrian traffic must be controlled for reasons of public safety and security.

*For more information contact: Securitron Magnalock Corp., 550 Vista Blvd., Sparks, NV 89434. Phone: 800-MAG-LOCK or 775-355-5625; Fax: 775-355-5636; E-Mail: info@securitron.com; Web: www.securitron.com. Circle 354 on Rapid Reply.* **TNL**

**ABUS**

Insurance Lock (ABUS) No. 37/80 pat. pend.

33AL45 Blue

33AL45 Red

ABUS N-83CS/55 HARDENED

Diskus 2070

**Not All Locks Are Created Equal**

800.352.2287 **ABUS** www.abuslock.com

Circle 203 on Rapid Reply

**TekTone**

**Versatile Telephone Entry Systems**

Our Tek-ENTRY® apartment entry system has the features your customers require:

- programmable for 1-750 suites
- 7, 10 or 11 digit dialing
- no phone line option

Call 800-327-8466 or visit [www.tektone.net/tnl5.htm](http://www.tektone.net/tnl5.htm)

277 Industrial Park Road • Franklin, NC 28734  
4190 Fairview Street, Unit B-8 • Burlington, ON L7L 4Y8

...clearly the best.  
800-327-8466  
[www.tektone.net](http://www.tektone.net)

Circle 277 on Rapid Reply



Version  
5.0

# Electronic InfoBase Edition (LSS+)



by  
**Richard Allen  
Dickey**

Information is a powerful thing. With it, almost anything is possible. Without it, you will be held back by the limits of your own ability and imagination.

There are many sources of information. You may find a little here or a little over there. Some in this book and some in that book. You could spend a lifetime acquiring information. Then you would have to ask yourself how you would sort through the mass of information to find exactly what you are looking for.

What if someone else found and compiled over a million words of written information for you. Not good enough? Well, let's add approximately 100 hours of audio and video information. Still not interested?

Lets go one step further. What if you could sit in front of your computer and watch someone show you how to impression a lock or decode a masterkey system? No kidding!

Well, Marc Weber Tobias has done just that. He has compiled an information treasure trove in a massive book called Locks,

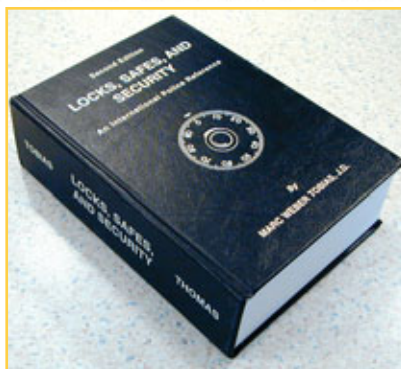

1. This is where it all started. *Locks, Safes and Security*, published on December 27th 2000, is a 1400 page work of art. It covers every conceivable aspect of physical security. The book has well over a million words and around 550 photos and illustrations.

Safes, and Security (see photograph 1). (See the September 2001 issue of *The National Locksmith*)

Next, he put all of this information in a database to make searching for information quick and easy (see photograph 2). (See the July 2002 issue of *The National Locksmith*)

Now for version 5.0 Marc has added over

100 new audio and video interviews and demonstrations (see photograph 3). There are more than 100 additional photos. He has also added approximately 150 new sections to the book with numerous updates and additions to existing sections.

There is no other collection of information like this anywhere in the world, nor is there likely to be. Who is this guy? Let me give you a brief overview of Marc and talk about some of the controversial information in this book.

Marc Weber Tobias has authored four law enforcement textbooks dealing with criminal law, police communications, and security. Tobias received a



2. Photos in the electronic version are good. The search engine makes it easy to find what you are looking for.



# The Ultimate Security Gate Latch

**LOKK•LATCH® PRO**



Patent No. 6513351

**NO RUST**

- Can be master-keyed
- Fits metal, wood & vinyl gates
- Limited Lifetime Warranty

See us at  
**ALOA  
BOOTH  
954**

Lokk•Latch® PRO is the most sophisticated privacy and security gate latch ever devised. It is *the* privacy latch that locksmiths and security businesses have been raving about!

**This quality, patented latch can be operated and locked from either side of the gate!**

Lokk•Latch PRO is uniquely constructed to work effectively in both residential and commercial gate applications. The "External Push-Button Access" component fits to the outside (street side) of the gate post to provide convenient, key-lockable access.

It uses a standard 6-pin key-in-knob style lock cylinder. This cylinder can be keyed-alike, maison-keyed and master-keyed, or can be replaced with a high security cylinder.

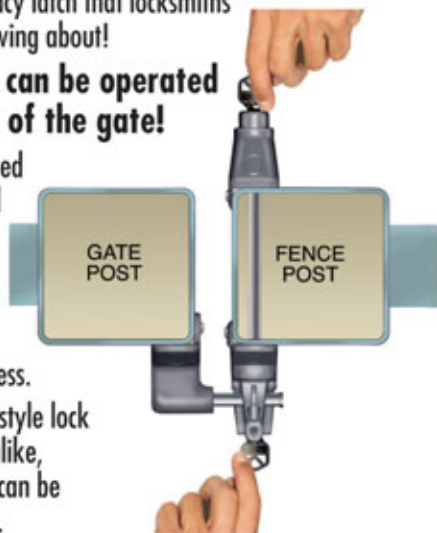

Popular add-on for  
**STOREFRONTS**

Patent Pending



Model: FHSSR

**Forté™**

## The Security Lock with Style

The **Forté™ Hasplock** introduces a new standard in quality commercial and industrial locking security.

Forté HaspLocks (4 models) are designed for all types of storefront, door, gate and storage locking, either as add-on security for existing locks or as primary locks.

Made from 316-grade stainless steel, the Forté Hasplock is particularly ideal for use in marine or other corrosion-prone environments.

Forté Hasplock is highly resistant to hacksawing, levering and oxyacetylene cutting.

Vending machines using "hinged" models



Toolboxes & Storage



Gate Security - no padlocks or chains



**d&d technologies**  
**Safety, Privacy & Security**

Circle 216 on Rapid Reply

D&D Technologies (USA) Inc., 7731 Woodwind Drive, Huntington Beach CA 92647  
Tel: (800) 716-0888 ext. 231 Fax: (800) 464-6400 E-mail: gateware@ddtechusa.com Web: www.ddtechusa.com





Continued from page 72

Bachelor's Degree in 1970 from the University of Nebraska-Omaha, and a Juris Doctor Degree from Creighton Law School in 1973. He is an attorney in Sioux Falls, South Dakota, with Investigative Law Offices, P.C.

As part of his practice, he routinely conducts technical fraud investigations and consults with corporations and government agencies throughout the world regarding the bypass of locks, analysis of design defects, and security liability issues.

Tobias is also a technical advisor to the Association of Firearms and Tool Marks Examiners (AITE). Tobias has provided technical support and investigative services involving surveillance, covert entry, interrogation, polygraph, and crime scene documentation to many law enforcement agencies throughout the world.

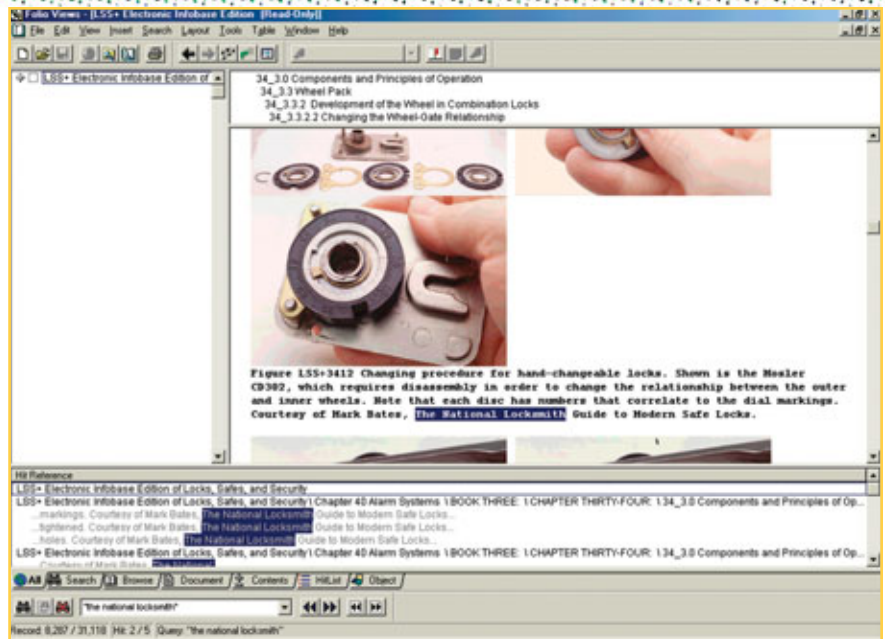

3. The first screen of version 5.0 introduces you to the product.

Now that I have told you a little about who this guy is, I want to bring up one of the most controversial topics that I have heard in many years. A topic that is covered in extreme detail in both text and video information by Marc Weber

Tobias. This is the topic of the masterkey system.

Exactly how secure is a masterkey system and should we even be discussing such a thing? There are those that believe ignorance is bliss. The less it is discussed, the fewer people there will be that know how easy it is to break.

There is also the other extreme that consists of individuals that can see a law suite coming in the future. That law suite will be directed at some well insured locksmith shop that failed to inform a client of the shortfall of the masterkey system. A shortfall that cost the life of someone that was supposedly secured by that masterkey system.

I have paid little attention to the masterkey issue since it popped up a year or two ago. That is until now.

While talking with Marc on the phone, he mentioned that the problem with masterkey systems was covered in his ready to release update. He explained how easy it would be to create a top level master key for an entire facility by anyone with the most basic knowledge of how a lock worked.

**Reliable, Convenient,  
Economical,  
Secure,  
and of course...  
Profitable!**

**NEW  
Line of Fire  
Safes  
Now  
Available!**

**PACIFIC  
SECURITY  
PRODUCTS CO.**

Fire Safes  
Floor Safes  
Steel Body Safes  
Rotary Hoppers  
Specialty Safes

Warehoused at: Los Angeles,  
Houston and New Jersey.

1641 W. Main St., Suite 211, Alhambra, CA 91801  
Calif: 626/570-4655 • Nationwide: 800/331-0785 • Fax: 626/289-2326





4. Video is viewed much like it would be on a home video player. Here you can see a video file playing at its normal size.

I have to say that it just didn't sink in until I watched the first two minutes of an eight minute video featuring Brian Chan that was included on the update. I couldn't believe that this simple process had never occurred to me.

I immediately watched a 14-minute video featuring Harry Sher on the same topic that walked you through the process step by step (see photographs 4 & 5).

Next I watched another 40-minute video that featured Matt Blaze. He showed in detail how a high school kid with only the most basic understanding of locks could end up with a key that would open any door in the entire school. Is that scary or what?



5. When the video file is enlarged too full screen, it is almost like sitting at the same table with the person giving the demonstration.

Should these topics be discussed in detail or should they be left in the dark? I have my opinion and I am sure you have yours.

The point of this article is that Marc has no problem with covering the tough issues that affect our industry. He has put many years of effort into his work and the quality shows.

If you want to know something about a specific lock, system, tool, process or patent, you will almost definitely find it in the Electronic InfoBase Edition (LSS+) of Locks, Safes and Security.

The 14 CD Electronic InfoBase Edition (LSS+) of Locks, Safes and Security is available from two different sources. HPC Inc. will carry security levels 1 and 2. All level 3 information must be purchased through MBA USA (Mark Bates Associates). The cost will range from around \$350.00 to \$600.00 depending on the security level purchased. If you have purchased the book, you may be eligible for a rebate when you purchase the CD-ROM set!

*If you would like to contact the author, there are several ways you can do it. Marc Weber Tobias welcomes feedback from readers. His e-mail address is [mwtobias@security.org](mailto:mwtobias@security.org) He can be contacted at (605) 334-1155 You can also reach him toll free utilizing Internet telephony or video conferencing through <http://www.security.org>. *



## Good looks run in the family.

It must be in our genes. And, now that the 0161 has been improved, our family is even more attractive. With an updated low profile face constructed of durable stainless steel and the same great features you've come to appreciate - the 0161 is sure to turn heads. And why not? It joins a long legacy of eye-catching strikes by Rutherford Controls. The new and improved 0161 strike. It'll get noticed.



Check out our entire family of video strikes!



In or Out... we make it Easy!™



[www.rutherfordcontrols.com](http://www.rutherfordcontrols.com)

**1-800-265-6630 • 1-519-621-7651**

# CORNER

## BEGINNER'S

### Crossbore Hole Adjusting



by  
Ken Holmlund

As often as not, it seems that when a lock needs to be replaced, the size, or location of the hole in the door is cut wrong (see photo 1). This is particularly true if the door is an older wooden one, but it can, and often does apply to older steel doors as well.

Sometimes both the hole location and size are such that you can adjust the hole to 2-3/4" backset from the residential norm of 2-3/8". I will often do so because it allows for more hand room to turn the knob, and therefore less likelihood of scraping a hand when opening the door. It is a small thing, but it may make a difference to your customer.

The question of how to go about moving or enlarging the hole has several answers, but there are also several factors to consider before doing so.



1. The hole in the door is cut wrong.

Among the factors are such things as marks already on the door from the lock, any existing plates, whether or not the door has a separate deadbolt, brand of lock you are installing, the tools you have to do the job, and your skill level in using the tools.

Lets look at some of the factors before going into the procedure of doing the job. Marks on the door: If the marks are too bad, I suggest telling the owner before proceeding. They may be aware of the problem, but they might just claim that you did the damage when you installed the new lock. If the damage can be covered by the rose of the new lock and allows for the movement of the hole from 2-3/8" to 2-3/4", by all means do so, otherwise don't move it.

If the door already has a "modernizing" kit installed to cover previously used holes, you are limited to using the same location if the plate will not cover the hole when it is moved. My experience tells me it is better to just leave it where it is in this case.

Window location or trim can present a major problem and will dictate what you can and can't do on the door (see photo 2).

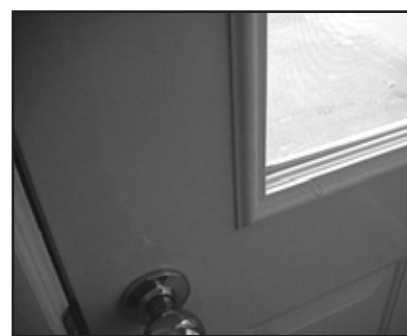

2. Window location or trim can present a major problem.

Often the location of the trim prevents movement of the hole since the trim would be inside the opening if you move it to 2-3/4". Another possible factor would be the location of the glass in the door. Sometimes it is impossible to know just where the glass edge is located. In that case, I would not try to move the hole and would use caution when cutting the new hole as well. Replacing glass in some of the old homes could get to be very expensive, so be careful.

If the door has a second lock such as a deadbolt, align the replacement lock up with the other lock (see photo 3). If they are the same, leave the new hole in the same location.

Some brands of locks will not require enlarging the hole to install a new lock. In that case, do not move the hole



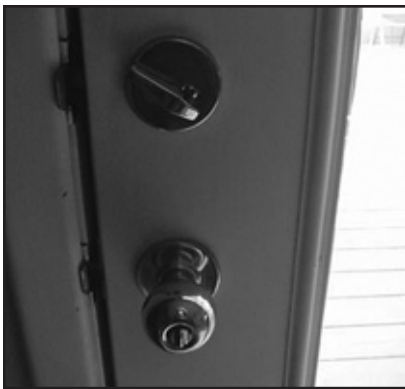

**3. Align the replacement lock up with the other lock.**

unless the rose of the lock you are installing is large enough to cover the marks on the door. It is better to leave a smaller hole and be able to cover it than to leave a visible hole in the door.

The tools to do the job are what this article is about and I will cover them in more detail later. Just suffice it to say, if you don't have an adequate tool, do not try to do the job freehand. Your skill level will



**4. A-1 Model BUL-2 Installation Tool.**

be tested if you do the job without the proper tools and the results will be less than satisfactory. Invest in the right tools to do the job.

Let's take a look at some of the available tools for moving and/or enlarging holes in doors.

The most common style of tool used would be the old standby—the jig. The same tool used to drill crossbore holes for a new installation of a



**5. Kwikset 136 Installation Kit.**

cylindrical lock or deadbolt. There are many styles and designs of jigs available on the market, so you have a wide variety of choices. Some of the available models include:

- A-1 Model BUL-2 Installation Tool (see photo 4).
- Kwikset 136 Installation Kit (see photo 5.)
- Locktools.com Model WJ-1 Wild Jig (see photo 6).
- Major Manufacturing Model HIT-44 Drillmaster (see photo 7).

# Our Inventory is Out of this World!

Free UPS Ground Shipping with All Online Orders!

800-522-2940 Midwest  
800-768-6050 Southeast  
[www.jlmwholesale.com](http://www.jlmwholesale.com)

ADAMS RITE / ALARM LOCK / ALTRONIX / BRADLEY / BREY & KRAUSE / DYNALOCK / ESSEX ELECTRONICS  
EXCEL DRYER / FOLGER ADAM / GLYNN JOHNSON / H.E.S. / I.E.I. / IVES / KOALA / LCN CLOSERS / LOCKNETICS  
NORTON / PRECISION / ROTON / SCHLAGE / SECURAKKEY / SDC / SELECT / SIMPLEX / TRINE / VON DUPRIN

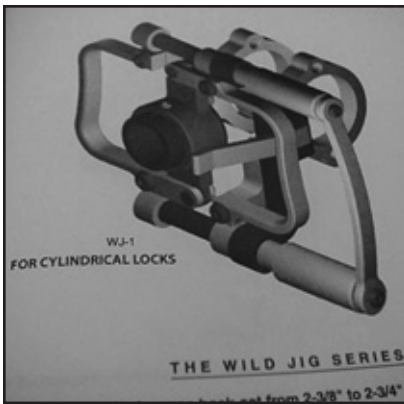

**6. Locktools.com Model WJ-1 Wild Jig.**

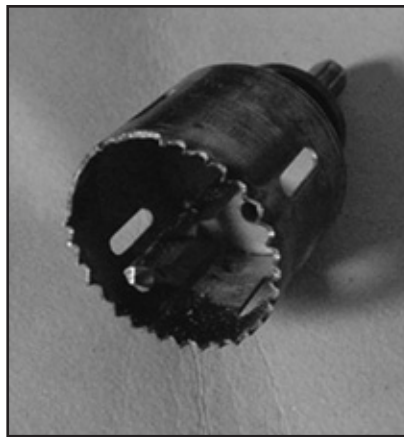

**9. A hole saw.**

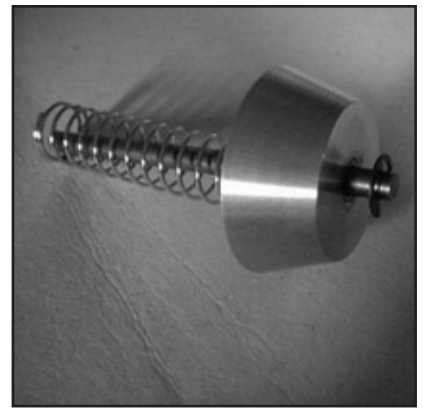

**12. The tool is shaped like a cone.**



**7. Major Manufacturing Model HIT-44 Drillmaster.**

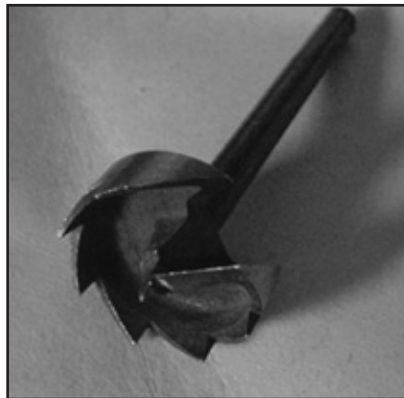

**10. A spur bit.**

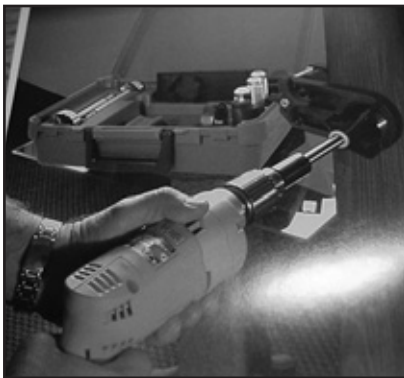

**8. PRO-LOK Model INJIG.**

- PRO-LOK Model INJIG (see photo 8).

The style of jig works pretty much the same regardless of which tool you use. They clamp on the door and serve as a guide for the drilling of the hole. I prefer using a hole saw (see photo 9), to drill the holes, but many use a spur bit (see photo 10). My reasoning for the hole saw is two fold. First, there is less sawdust mess to cleanup, and I do suggest

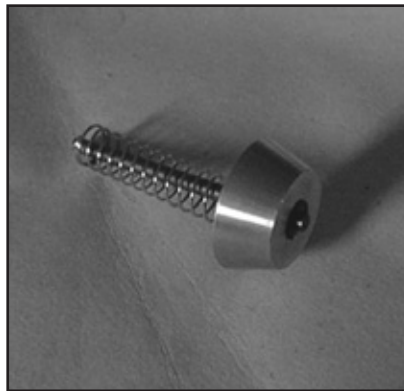

**11. The Hole Saw Alignment Guide.**

cleaning up behind yourself. Second, if you hit a nail or screw, the hole saw will cut right through it, but the spur bit may be damaged beyond usage. Everyone has their own favorite.

One word of caution when using an installation jig. Be sure you are drilling straight into the jig. A slight angle with the hole saw may catch the side of the jig and turn the jig, leaving a serious scar on the

door. Just use caution and a slow speed and the job will be done without mishap.

A company named Tri-City Lock Company has invented a totally new concept in enlarging holes in doors and it may just revolutionize the way the job is done. The tool I am talking about is called The Hole Saw Alignment Guide (see photo 11).

The concept is simple, place the tool into the existing hole to center the hole saw and the hole will be exactly the same backset when it is enlarged. The trick was to make the tool so it would fit several sizes of existing holes. Daniel Mello, owner of Tri-City and the inventor of the Hole Saw Alignment Guide, solved that little dilemma by making the tool in the shape of a cone (see photo 12).

The next challenge was to get the tool to slide into the hole saw when it was guiding the drilling process. He solved this one too. He mounted the guide on a hard shaft that slipped into the hole saw in place of the pilot drill and then placed a spring behind the guide to keep outward pressure on the guide during drilling. He did not attach the guide to the shaft, but rather used a C clip to keep it on the shaft. This

**Continued on page 80**



# TURN TOWARD THE FUTURE



## ONE COMPANY... ENDLESS SOLUTIONS



Safe locks are continuing to turn toward the state-of-the-art technology and the enhanced security provided by electronic locks. For a simple, surprisingly affordable upgrade of mechanical safe locks, LA GARD offers the LG Combo, an electronic keypad that works with LA GARD's electronic deadbolt. LG Combo is universal (fitting nearly every application), easy to install, easy to use and extremely reliable.

The LG Combo from LA GARD - more protection for your customers, more opportunities for you.

- **Exclusive entry pad**
- **No complicated dialing methods**
- **Same superior software as LG Basic or ComboGuard**
- **Low profile/ideal for floor safes**
- **Replaces most mechanical combination locks**

LGCombo, another powerful innovation from LA GARD.

**310-325-5670**

Offices Located Worldwide



LA GARD, INC. 3330 Kashiwa Street, Torrance, CA 90505  
Ph: 310-325-5670 Fax: 310-325-5615 Fax On Demand: 877-LAGARD2  
Email: theone@lagard.com www.lagard.com

# LA GARD

One Company... Endless Solutions

A MASCO Company (NYSE:MAS)

Circle 243 on Rapid Reply



13. The guide is pushed into the hole saw when cutting.

allows the guide to be pushed into the hole saw as it cuts into the door (see photo 13).

The only shortcoming I have found with the Hole Saw Alignment Guide is if the hole in the door is too small to fit the nose of the cone. This probably will not happen very often, but in my area I find a few people who cut out a hole just big enough to fit the post pattern of their old

lock. Sometimes they use a drill bit and sometimes they just cut the hole with a chisel. Either way it makes for a very unprofessional job.

I am sure some locksmiths still use paper templates, and maybe it works for them. My thinking is that there are many fine tools that can do the job professionally and quickly, so why mess with paper? I suggest having both the jig and the Hole Saw alignment Guide in your toolbox and you will be prepared to do any crossbore door cutting job professionally.

Contact information for the companies mentioned in this article are:

**A-1 Security Mfg. Corp**

Phone: 804-359-9003 or 877-725-2121

Fax: 804-359-9415

Email: fmcc@demanda1.com

Website: www.demanda1.com

**LockTools.Com**

Phone: 408-979-0337

Fax: 408-723-3377

Email: info@locktools.com

Website: www.locktools.com

**Major Manufacturing Inc.**

Phone: 714-772-5202

Fax: 714-772-2302

Email: mail@majormfg.com

Website: www.majormfg.com

**PRO-LOK**

Phone: 714-633-0681

Fax: 714-633-0470

Email: mail@pro-lok.com

Website: www.pro-lok.com

**Tri-City Lock Company**

Phone: 209-962-4692

Fax: 209-962-4910

Website: www.tricitylock.com



# Lightweight winner.

Kett's new KS-221 cuts plastic, aluminum, mild steel and more.

Now you can cut plastic up to 1/4" thick, aluminum to 1/8" and mild steel to 18 gauge with one rugged, portable power saw. Weighing just 5 lbs., Kett's new KS-221 Panel Cutting Saw maneuvers easily and cuts quickly and quietly. It's perfect for cutting gutters, siding, autobody panels and sign making materials. Because the KS-221 cuts clean, without burrs or burn, you can also save valuable fabricating time!

Powered by a rugged 120 volt AC, 4.5 amp, 2500 RPM double-insulated electric motor.



Write today for free bulletin

The Kett Tool Company  
5055 Madison Road  
Cincinnati, OH 45227-1494  
(513) 271-0333  
FAX: (513) 271-5318



## "SuperTuff" high security fire safes without the Price Tag!

Now capture both the Residential and Business marketplace with our new inexpensive line of high security fire safes.

- The SuperTuff is designed for businesses and homes needing more burglary protection without the intimidating size and cost.
- Steel reinforced composite construction; one hour fire rating; expandable fire gasket; U.L. group 2 combination lock; high quality adjustable hinges; 3 way boltwork (on 3219+); dual & electronic locking available; optional glass relocking system.
- Custom interiors & colors available.

For a full list of our product line, or an authorized INKAS® distributor in your area please visit our website.

**NOW LOOKING FOR NEW DISTRIBUTORS & DEALERS IN YOUR REGION**

**1 877 913 7233 • WWW.INKAS.CA**





# HARDWARE HARDWIRED

*Shouldn't be hard to find.* Don't be shocked when you call Security Lock Distributors and discover that we can deliver solutions for any electrified hardware situation. You name it: locksets, panic devices, hinges, pivots and mortise locks. We stock all functions, voltages, and switch options...along with power supplies, cable and all the technical know-how you need but can't find anywhere else! In fact, we can deliver electrified versions of any name brand product you ask for. So when the job calls for electrified locking hardware, there's only one number you need to call – ours.

**1-800-847-5625**

www.securitylockdistributors.com/email: info@seclock.com  
Boston, MA • Pompano Beach, FL • Las Vegas, NV

**SECURITY**  
**LOCK DISTRIBUTORS**

*Informed. In depth.*

Circle 273 on Rapid Reply

# THE Lighter SIDE

Worth the Price



“Want to ride shotgun?” Don asked our dinner guest. A service call had just come in that would take Don up country about twenty miles to the river-camp area. Joe and his wife had come to our home to have dinner and play cards with the understanding Don would have to tend to business, if a call came in, so it didn’t come as a surprise.

“Sure,” Joe replied, smiling. “I’ve always wanted to see what all you guys do to get into cars and make keys.

“I’m not sure I’m going, yet. The lady’s trying to decide whether I’m worth the price or not. Said she’d call back in a minute.”

The lady had said the keys were locked in the trunk, and she had no way of getting in, but the labor plus time and mileage up there was more than she’d planned on. Back and forth she’d gone in her thinking. She called back to ask a couple of questions, then said she’d have to think about it some more. Then she called again—all this, long distance—trying to talk the price down. When she said she’d have to see if she could come up with the money, Don figured it was a lost cause, but she surprised him. The next time she called, she said, “Come on.” She assured him she had the money in hand. “I just hate to part with it,” she said.

A small crowd had gathered around the vehicle to lend moral support, if nothing else, by the time Don and Joe arrived at the site. Joe stepped aside while Don surveyed the situation. As he’d hoped, the trunk could be opened with an electronic push-button inside the glove box. All he had to do was unlock the door and “hot wire” the trunk opener with his handy, jim-dandy little light-cord “jumper cables.”

He set about opening the door. That’s when the alarm system went off. Now, this isn’t unusual, but Don hadn’t expected it in such an older-model. As the squalling went on and on, more and more curious on-lookers gathered about, shouting their suggestions and comments above the wailing siren while Don, under pressure, worked to open the door.

Finally he got in, opened the glove box, pressed the button, and the trunk sprang open, to the delight of Joe, the customer, and the assembled cheering squad.

The customer immediately dove into the contents of the cluttered trunk, pawing through this and that in her search for the keys she knew were there.

No luck.

“Oh, my,” she wailed. “Now what am I gonna do?”

“Mama? What’s going on?” The lady’s grown daughter ambled up,

pushing a baby in a stroller. The older woman told her about locking the keys in the trunk and finally calling the locksmith.

“But I’ve looked through everything and the keys aren’t there.”

“Are you talking about that ring of keys with the big red whistle on it?” the daughter asked. “They’re right here. Don’t you remember? You dropped them in the diaper bag when you were giving Billy his bottle after his nap.” Reaching into the diaper bag, she produced the missing keys and handed them to her mother.

“Man oh man, that woman was unhappy,” Joe laughed when telling of it later. “She had to pay Don all that money for coming up there and getting her trunk open, for nothing. She was growling at her daughter, at Don, at everybody except herself.”

“Isn’t it interesting, how it’s never their fault?” Don injected.

“I can just see her now, slapping those bills in Don’s hand one at a time while cussing out everybody for miles around. I never heard a lady use those kinds of words before.”

“She should be glad her daughter came up with those keys when she did,” I offered. “If Don had been forced to make a new set of keys from scratch, it would have gotten into a whole lot more money than that.



"I bet that's right," Joe said. "You know, I'm about to decide I'm in the wrong business. I don't know when I've had such fun."

"Well it took you long enough," I said, anxious to get back to our card game.

"That's because Don got a couple more calls while we were out," Joe said. "Somebody up on the river was trying to pack up to go home, and they couldn't get their trunk open."

"Had they lost their keys or locked them inside?"

"Neither one. In fact, they had two sets of keys, and neither one would unlock the trunk. They would go in, but they wouldn't turn," Joe said.

"Did they have the wrong set of keys, or what?" I asked.

"That's what Don asked them, and they assured him what they had were the only keys they owned, and they'd worked just fine earlier in the day. Don put graphite in the lock and ran each

of the trunk keys in and out of the lock, but neither one would turn."

"So, were you able to help them?"

"Oh, yeah. It was simple, really," Don said, grinning. "This was another vehicle that had a trunk-release in the glove box, so I got the guy who owned the car to sit up front and push the release button. Then everybody else got up on the trunk and bounced around as much as they could, while I jiggled the key and tried to turn it in the lock."

By this time, Joe was laughing so hard tears were rolling down his cheeks.

"You should have seen 'em," he said. "It looked like a clown act at the circus. Then, all of a sudden the trunk popped open and they all jumped off."

"Did you ever find out what had caused the problem?" I asked.

"You wouldn't ask, if you'd seen what was inside. I couldn't believe what all they had crammed into that trunk—picnic

stuff, lawn chairs, beach towels, you name it. But I think it was the Styrofoam surf boards that did it. They were wedged in pretty tight. They had to force the lid down pretty hard to close it."

Joe's laughter had tapered off some, and he was wiping his eyes. "You know, I don't think I've had this much fun since my big brother sat on a hornet's nest. Are all your service calls like that?"

"No. I guess we just got lucky this evening." Don shrugged at me behind Joe's back.

"There's only one thing," Joe continued. "My ears are still ringing from the car-alarm at that first stop. I don't know how you could work with all that noise going on."

"It helps to be a little deaf."

"I didn't know you had a hearing problem."

"Yep." Don smiled. "It hit me about the time they started putting alarm systems in cars." **TRU**

## CyberLock The Lock on Intelligence

**Who!**      **Where!**      **When!**      **What!**

Key Name	Lock Name	Date/Time	Status
Joe Wilson	East Entrance	03/20/2000 06:14:22 AM	Denied
Abby Chaney	West Entrance	03/20/2000 07:28:03 AM	Key Authorized
Pete Sussman	Records Room	03/20/2000 07:59:15 AM	Out of Schedule
John Michaels	Computer Room	03/20/2000 08:00:03 AM	Key Authorized
Evelyn Letler	West Entrance	03/20/2000 08:12:16 AM	Key Authorized
Juanita Banks	Computer Room	03/20/2000 08:18:52 AM	Key Authorized
Andy Dunsmore	Computer Room	03/20/2000 08:27:12 AM	Denied

The new remote CyberKey<sup>®</sup> Authorizer™

CyberLocks . . .  
An entire access control system for doors, safes, padlocks and cabinets!

- Eliminate key control problems
- Schedule access times
- Record all openings and attempts
- Update user permissions remotely

Call Videx today for more information on the latest in access control for your entire operation.

541-758-0521 • sales@videx.com

www.videx.com/lock3

GC01778



# MAJOR RUSTIFICATION

**Y**es, I know “Rustification” is not a real word, but in the world of safecracking, it is an important description of a condition of older safes stored in wet and damp areas. They can be rusted both externally and internally. The bolts may be coated with oxidation, the moving parts not stirring, and in the extreme, the door not opening with the combination lock opened.

In fact, most service people who work on vault doors know the importance of non-rusty bolts and bars. A large part (and important) of vault door servicing is the proper removal of rust with emery cloth and the proper lubrication of all moving parts within the door. After that is accomplished, the combination locks should also be cleaned, aligned, and lubricated. As on safes, the dial rings, dials, and splined drivers should also be checked for tightness and wear patterns.

Most lock parts are susceptible to some sort of oxidation,



by  
**Dale W. Libby,**  
**CMS**

but not of ‘rust’ per se. Most combination lock parts are made of brass or some other metal that is rust and oxidation resistant. However, these lock parts still need some sort of lubrication, even those Diebold locks marked with the legend “Do Not Lubricate!”

This article is not specifically about what lubricants to use, but some guidelines on good servicing procedures. What lubricants you use are justified by your experience and the climate that you specifically work in. I do not want to start any arguments on which product is better.

Customers lose the thought that safes, vaults, and even door locks are objects that need lubrication and service occasionally. This is especially true of automobile locks in outside weather conditions from salt spray to ice and

snow. Most of the problems with safe locks and inner door mechanisms cannot be seen by the customer, and must be repaired by the service technician. This should happen when the service technician is called on to change the safe combination.

Changing a safe combination is more than just sticking in a change key and redialing to a new combination. It should include taking the back cover of the lock off and checking tightness of the lock case screws and the lever screw at a minimum. The tightness of the spline key and the drive cam should always be checked. If this is the first time that you are working on a particular safe, then the spline key should be removed and the dial unscrewed. By doing this, you can check for tightness and proper alignment of the dial ring.

If I suspect any trouble with a dial ring, I align it, tighten it, and then install pop rivets. This usually keeps the dial ring from extra random movement. This is called and invoiced by me as complete safe R&R and combination changing. Yes it takes longer than

**Continued on page 86**





**THINGS THEY  
CAN DUPLICATE**



**THINGS THEY  
CAN'T DUPLICATE**



With the patent-pending **Master Lock Key Control System**, your facility's keys will be safe from unauthorized duplication. And your bank account will be safe too, with the first, truly affordable key control system. To learn how cost-effectively you can upgrade your padlock and door security, call 800-308-9242.

**Master Lock.**

Circle 251 on Rapid Reply





**1. Upper Door of MAJOR over and under double door safe.**



**2. Lower Locked smaller target door with ILCO dial.**

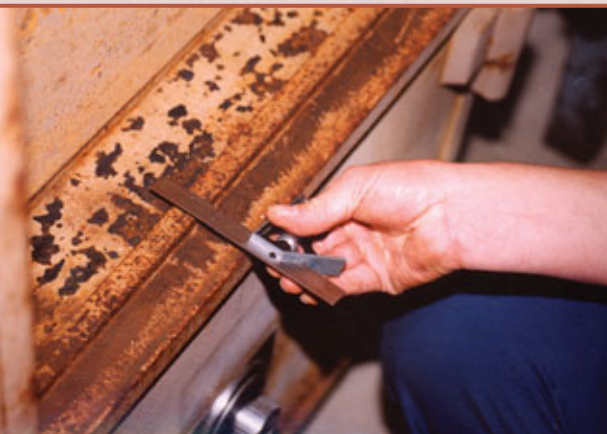

**3. After taking measurements from open upper door mechanism, we transfer the same measurements to the floor of the upper compartment, which is also the top of the bottom safe.**

a simple combination change, but so what? When you are servicing a safe you are putting your name on that safe door and lock until you work on it again. You do not do this for free. You must charge for it accordingly.

I do have customers that only want the combination changed for the least amount of money, and this I will do. However, I make sure that the customer knows that there is no guarantee, implied or written unless the lock is taken apart and checked. Some customers do not care. Pound wise, and penny foolish. I will see them again.

The rusty safe in this article is a Major double door over and under unit. The upper door is rather large with the smaller door beneath. The upper door is shown in *photograph 1*. It is in the unlocked position. The handle moves counter-clockwise after the combination bolt has been pulled into the lock case. The lower door was a much smaller version of the upper door. Due to space limitations, I could not get a picture of the entire safe at one time. The lower door is shown in *photograph 2*.

The upper door had a Sargent & Greenleaf spy proof dial and ring. The lower safe had an ILCO dial and ring installed. This is a giveaway that the lower safe had been worked on before, and the dial and ring, possibly also the lock had been replaced at one time.

Do not take anything for granted at first look. There is no sure way to tell what is happening on the inside of the safe door until you get there. I thought that the lower door still probably had the S&G lock and cover because of the rather complicated relock cover attachment. We will soon see if I was right.

When working on a double door safe, often the same locking arrangement is used in both doors. On this unit, the customer who kept this safe in a wet garage type building was using the upper large compartment for storage. He never had the combination for the bottom safe door and wanted to use it for additional cargo space.

This safe was in Rockford, Illinois. This means a Dale and Bob Sieveking opening and attack. The customer just wanted access to the bottom compartment with the same combination as the top safe. (If you see a magnetic scale in the picture, you will know that I am with Bob) The first thing we tried was to dial the upper combination to the bottom safe lock. This did not work. I tried a little manipulation, but got light readings. The dial seemed to spin too freely.

One of the advantages of having the open upper door was that we could see exactly what we were up against. It was a Major TL-15 configuration with relock cover that guarded not only the safe spindle from being punched, but also cam punching. If anything was punched, we would have to face the diabolical relocker/flapper relock mechanism. This relocking device is not fun to defeat. From the side it is easier, but from the front of the safe, it is a real bear of a job. There is a nasty hardplate that protects it and there is almost no way to get the proper angle to punch the cross locked relocker.

This relock bolt is spring loaded from the side and the front. If it is set off, it springs toward the opening side of the safe door and then is pushed up against the square bolt retainer. This in effect cross locks the bolt and it is hard to push back, even when you are working on it from inside the safe with the door open. After measuring the depth





**4. Borescope and shop rag inserted in the 1/2" drilled hole to view the change keyhole in the lower combination lock.**



**5. Door opened showing combination lock cover with attached complex relock activation bar.**

and placement of the change key hole, we transferred these measurements to the bottom door. The hole we drilled was about 4" back from the front of the door in line with the change key hole to the right of Dial center about 1/2". In *photograph 3*, Bob is using a square to properly measure this position.

The hole would only be visible when the upper door was open. We were going into the top of the bottom safe through the floor of the upper safe. Because of the excessively low price that Bob quoted, this was going to be a quick in and out job. We commented about the rusty condition of the upper safe and the customer said he would take care of it as well as rehabbing the bottom safe door mechanism after we got the combination to work. It would not even be necessary to fill the bottom hole with a plug. He wanted it cheap and fast. We wanted to oblige, and we did!

We decided not to get to technical. Instead of the regular 1/4" hole, I opted for the standard (to cover slight variations in mis-measurement) hole of 1/2". We had about 1-1/2" of steel to drill through and I did not want a slight angle to keep us from hitting the exact mark. After drilling through the top of the bottom safe, we hit an intact sheet metal cover over the combination lock mechanism. Bob decided to put a 1/4" hole in the cover. The cover was loose on the door, and the 1/4" hole was a little off, and we could not see into the change key hole. Trying to re-drill the hole was not possible.

To remedy the situation, I inserted a drift punch to try and make the hole a little larger so the Hawkeye scope could be properly placed. Imagine my surprise when I punched the back cover with a small sledge and the cover popped off the back of the safe door. It had rusted all the

MBA

USA, INC.



CASH-LINK Parts Set



Replaces obsolete parts in Tidel Tacc II cash handling safes. Call MBA USA for more information. \$385.00 + S/H

MBA Tools & Training:  
THE RIGHT COMBINATION

Toll Free 1-888-MBA-5495 · [www.mbausa.com](http://www.mbausa.com)

FREE FREIGHT\*

F



MAYFLOWER

800-221-2052

[www.mfsales.com](http://www.mfsales.com)

INMETRONYC/718-622-8785

FAX/718-789-8346

EMAIL/pilgrim@mfsales.com

\*Shipments over 200.00 to UPS Zone 2 locations are prepaid as are shipments East of the Mississippi that are over 350.00 and West of the Mississippi that are over 500.00.



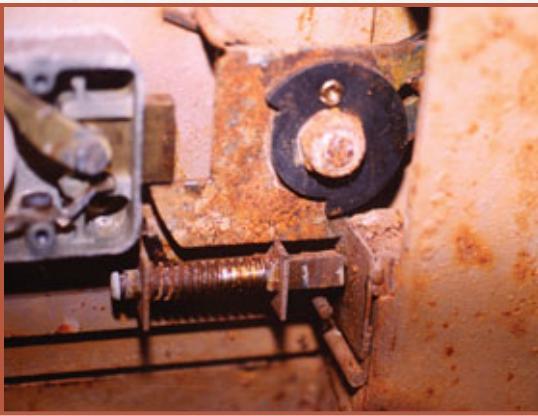

**6. Combination cover removed showing how relock plunger should be.**

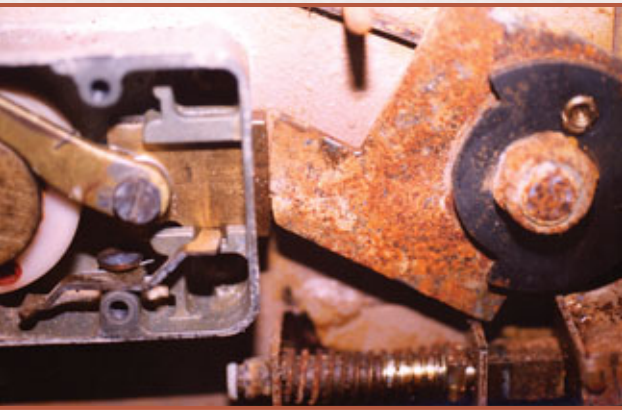

**7. Lock opened showing the relock plunger rusted into the open position.**

way through and my little hit took it off the door. We now had perfect placement for the scope for viewing.

It would be perfect if the scope didn't move so much. Bob solved this problem by gently shoving a shop rag into the 1/2" hole around the scope tube (see *photograph 4*). With the rag inserted the scope could be easily positioned and held into place while reading the wheels. If we had

bothered to take apart the upper combination lock, we would have not been surprised to see white plastic wheels. The S&G lock had the plastic Delron wheels popular many years ago. This is why I felt the dial spin so freely. Plastic wheels give a slightly freer movement that metal wheels do in most cases.

The nice thing about S&G wheels is that the key change hub is RED. It is easy to see against the white background of the wheel body. There are no rivets to see or gauge, and the red does show up nicely when spinning the wheels to determine numbers. We figured out the combination to the change index and then transferred to the opening index. The lock opened up right away, but the handle took a little persuading before it would move down all the way.

*Photograph 5*, shows the rusticated inside of the door. The handle cams, the flappers, the relock bolt, and the relock hold back cover parts are coated in rust. Even the lock case is oxidized, although not technically rust. *Photograph 6*, is taken a little out of sequence to show a point. This is how the relock trigger should be after the cover is taken off. It

is fully extended and pushing against a flapper that fits into a cutout on the internal bolt bar.

The way to beat this cross-locked relocker bolt is drilling from the side of the safe about 1-1/2" either above or below the bolt, and punching the flapper back with a large, long drift punch or a piece of 5/16" metal rod. The bottom spring that pushes the relock bolt cannot be seen in this photo, but it is there under the bolt.

*Photograph 7*, shows what happened when I removed the cover of the lock. The relock did not spring into action. It was Rusticated in Place (RIP). Usually RIP means Rest in Peace (Requisite in Pace), but can also mean Rusted in Place, or in referencing my service van, Rusting into Pieces). Whatever, you know what I mean.

We lubricated everything except the lock with penetrating oil and gently tapped everything, including the relock bolt to get it to work again. After servicing the lock we put everything back together and greased the hinges as well as the bolt mechanism. Other than being rusty, the door worked rather well. Bob then sealed our access hole anyway. After cleaning the rust from our tools, we left the customer happy.

When changing a safe combination, check everything out, clean, lube, and tighten.

Service and Prosper. **TRL**

**The Fastest, Most Efficient Loading Trailers...**

- Switch from Ground to Transport to Dock Height in Minutes
- 7,500, 10,000 or 15,000 lbs, Dual Axle Model
- Tongue or Gooseneck Hitch

**LIFT-A-LOAD Elevating Platform Trailers**

**Call 800-369-5365 for Information!**

Manufactured by: The Advance Metalworking Company, Inc.  
 P.O. Box 465 • 3726 HWY 34 • Kewanee, Illinois 61443 • Tel: 309.853.3387 • Fax: 309.853.3389 • www.lift-a-load.com • tamco@lift-a-load.com



**BUSCH**

**DiscountKeyMachines.com**

**800-332-8724/407-352-0590**

**"The Key Machine Superstore"**

**Always The Best Prices On**



**Promotions On All Key Machines For Show Attendees**



**By Popular Demand**

**The PAK-A-PUNCH VALU-SET With Free Keys Is Back!!**



**Promotions On All Key Machines For Show Attendees**

***See The New CodePro 4500 Electronic Key  
Machine Demonstration!!!***

**See Us In Booth #1123 At ALOA For  
SPECIAL SHOW ONLY PRICING!!**

# 2002 LINCOLN LS

A new ignition lock and an encrypted transponder key blank.

by



Tom Seroogy



Randy Mize

## IGNITION LOCK



As stated previously, the ignition lock on the LS is the very same ignition used by the short-lived 1997 through 1998 Mark VIII. STRATTEC is currently the only manufacturer of this lock, using part number 703596. The key, STRATTEC 599902 (Lockmasters LKMH74PT), is also unique to this car; using an encrypted Texas Instrument transponder chip and the Ford 8-Cut keyway.

## PART 1

Virtually unchanged from its previous year's release, the Lincoln LS incorporates several unique features for the locksmith. Among these



are an ignition lock, first introduced on the 1997 Lincoln Mark VIII, and an encrypted transponder key blank. Currently, neither the key nor the lock are used on any other North American Ford/Lincoln/Mercury vehicle.

## OPENING



Opening the LS is a simple task using either an Under-The-Window tool or by prying the door back and using a long tool to activate the lock button. To unlock the LS using the Under-The-Window tool, first make room for the opening tool by wedging the window.



Insert the Under-The-Window tool into the door and maneuver it into position. Pull out on the handle or toggle the door lock button to unlock.



Although this particular key looks very similar to the more common STRATTEC 598333 (Lockmasters LKMH72PT) Ford transponder key, they cannot be interchanged! To help distinguish these keys apart, the LS key blank provided as both the original key and the STRATTEC key will have a two-digit marking - a letter followed by a number - on the blade of the key, and the transponder cap or cover will be gray in color.





The ignition lock on the LS is found on the dash. Removing the ignition lock on the LS is quite simple and does not require any column disassembly.



Begin by carefully prying up and removing the trim plate surrounding the ignition lock.



The plate is held to the dash using a couple of clips. Be careful not to break these clips.



The transceiver ring for the transponder security system is fully exposed at the front of the lock, and although not readily apparent, the lock's retainer is now accessible.



To release and remove the lock, insert a working key, pick or drill and turn the lock to the ON or RUN position.

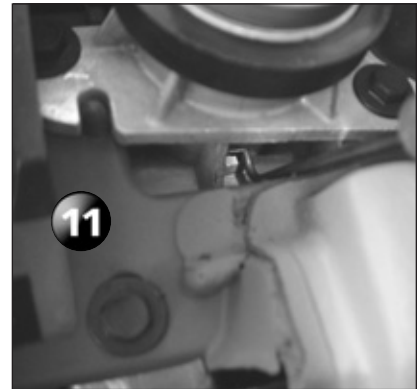

Locate and depress the retainer.

## Mark Your Keys!

Key Shop Name \* Security Code  
Special Instructions



### CUSTOM STAMPS

We can customize an Evers stamp with your trademark, code, special lettering, shop name etc. Submit design, lettering and size area for quote.



**ORDER TODAY**

**DIRECT FROM MANUFACTURER STOCK IMPRINTS:** "Master," "Do Not Duplicate," "Do Not Copy," "U.S. Property," "Property of U.S. Gov't," and "Unlawful to Duplicate"

## Key Stamp Holder

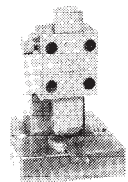

for 3/8" x  
3/4" Shank

Quick and simple to use for faster, easier marking

NO. E6H

**Security Code Stamps**  
500 different symbols

**FREE BROCHURES**

**HENRY A. EVERS CORP.**  
72 N. Oxford St., Providence RI 02905

**TOLL FREE: 1-800-55-EVERS**

Phone: 401-781-4767 Fax: 401-781-9581

# Sesamee®

## Keyless Security

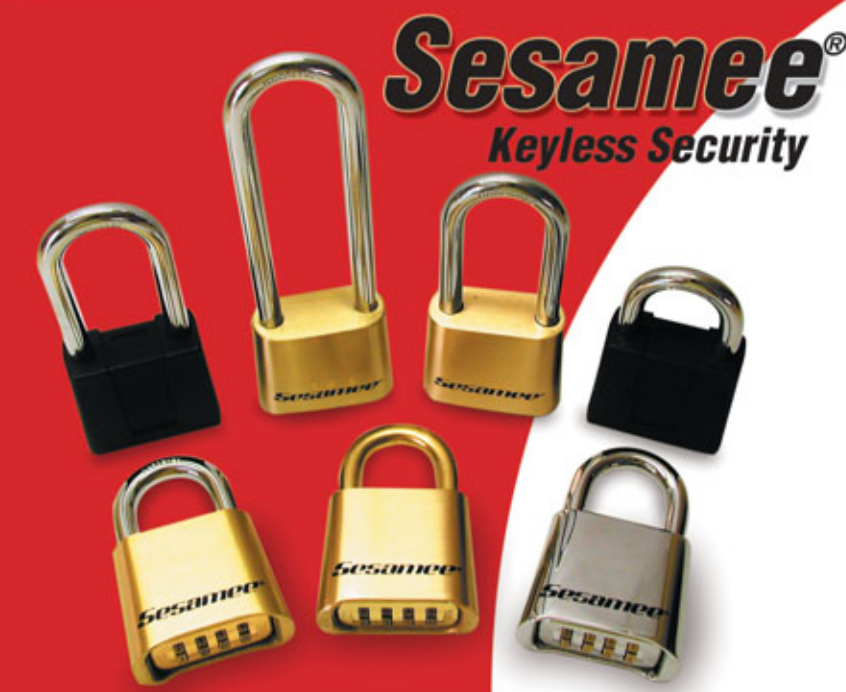



**CCL**  
Security Products

301 West Hintz Road  
Wheeling, IL 60090  
Telephone: 800.733.8588  
Fax: 847.537.1881 • [www.cclsecurity.com](http://www.cclsecurity.com)

- No Keys to Carry, Lose or Break
- Re-settable Combination
- Brass and Hardened Steel Shackles
- Ideal for Chain Link Fence and Gates
- Construction Job Sites and Gang Boxes
- Tool Cribs and Supply Areas
- Marine Use
- Oil, Gas and Pipeline Security

## DOOR LOCK

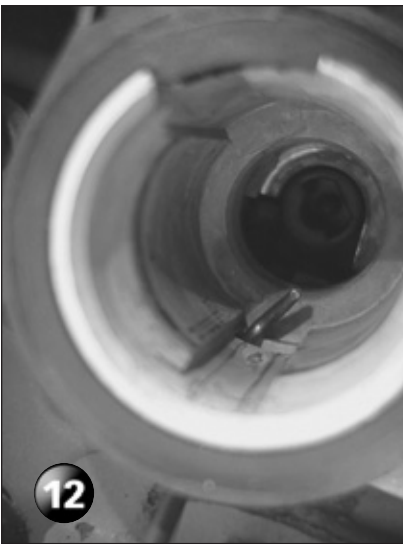

**12**  
The retainer is located at the 6 o'clock position, about 1-1/2" back from the face of the lock.



**13**  
Use a right angle scratch awl to depress the lock's retainer and remove the lock.

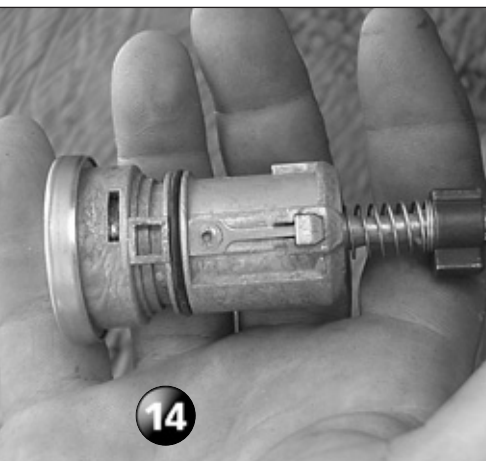

**14**  
The removed lock

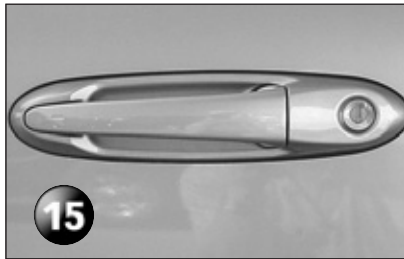

**15**  
A door lock is present on the driver's door only



**16**  
Despite first appearances, the door lock is fastened behind the handle and is not part of the handle.



**17**  
Fortunately, door panel removal is extremely simple on the LS.



**18**  
Begin door panel removal by first lifting the small trim cover that hides two screws in the cup of the armrest.



**19**  
Gently pry the window control button panel up from the front and lift it out of the armrest.



**20**  
Disconnect the connector from the bottom of the panel and set aside.



**21**  
Now remove the inside handle trim.





# Your Neighborhood Distribution Center

**NOW**  
**46**  
Locations

## STOCK LOCKS

Standard Locks for Special Needs

**Shipped In  
24 Hours**

## The World's Most Complete Stock Program

**Visit Us  
Online  
IDN-INC.COM**

Corp. Hqtrs  
Grapevine, TX  
817•421•5470

Albuquerque, NM  
505•816•0100

Atlanta, GA  
404•898•8740

Buffalo, NY  
716•626•1208

Calgary, Alberta  
403•291•4844

Chicago, IL  
708•456•9600

Cincinnati, OH  
513•271•8530

Cleveland, OH  
216•335•9740

Columbus, OH  
614•436•6619

Dallas, TX  
972•664•1240

Davenport, IA  
563•391•8366

Denver, CO  
303•922•3041

Detroit, MI  
810•755•3658

Edmonton, Alberta  
780•944•0014

Fort Worth, TX  
817•284•5696

Grand Rapids, MI  
616•534•1067

Halifax, Nova Scotia  
902•468•1373

Hartford, CT  
860•296•7886

Houston, TX  
713•668•0022

Indianapolis, IN  
317•635•8100

Jacksonville, FL  
904•387•0663

Kansas City, KS  
913•599•4111

Las Vegas, NV  
702•736•4553

Livonia, MI  
734•591•1150

Los Angeles, CA  
562•463•4870

Memphis, TN  
901•795•2250

Miami, FL  
305•651•1598

Milwaukee, WI  
262•790•9750

Minneapolis, MN  
952•886•3840

Montreal, Quebec  
514•956•0248

New Orleans, LA  
504•837•7315

Norfolk, VA  
757•853•0611

Oklahoma City, OK  
405•942•8750

Omaha, NE  
402•592•1652

Orlando, FL  
407•297•7722

Ottawa, Ont.  
613•749•2172

Philadelphia, PA  
215•288•5588

Phoenix, AZ  
602•272•5300

Pittsburgh, PA  
412•771•6122

Raleigh, NC  
919•227•0007

San Antonio, TX  
210•545•3396

St. Louis, MO  
314•692•8391

Mattydale, NY  
315•455•9305

Tampa, FL  
813•886•8007

Toronto, Ont.  
416•248•5625

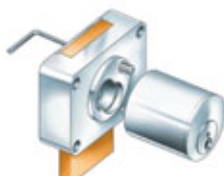

**CompX**  
NATIONAL

FULL PRODUCT LINE  
OF SECURITY LOCKS  
"THE ADVANTAGE PLUS"



**CompX**  
TIMBERLINE

LOCKS FOR  
WOOD FURNITURE



**CompX**  
FORT

MULTI-FUNCTION CABINET LOCKS



**CompX**  
CHICAGO

HIGH SECURITY LOCKS TO  
THE VENDING INDUSTRY

100 years ago **National Lock** began making quality cabinet locks and in 1968 founded the **STOCK LOCKS** program, offering pin tumbler and plated disc tumbler cabinet locks plus a complete line of mail box locks.

With the addition of **Fort Lock** in 1998 the program was expanded to include STS capped single and double bitting disc tumbler locks and showcase locks.

With the addition of **Timberline Lock** in 1999 came a complete offering of small diameter, core removable replacement wood furniture locks and mechanisms.

With the addition of **Chicago Lock** in 2000 the popular ACE® tubular lock products were added to the **STOCK LOCKS** program.

Together, under the **CompX Security Products** umbrella, we offer over 1500 stock keeping units and represent 252 years of cabinet lock manufacturing experience beginning in 1903.

**STOCK LOCKS** is the broadest coordinated program of cabinet locks in the world, and **you can insist on the STOCK LOCKS brand** for your security needs.

**We were there for you then — and we're here for you now!**



*Poly bags are color coded by company and bar coded. Multiple finishes available in stock.*

**CompX**  
SECURITY PRODUCTS

For more information  
contact your local  
IDN distributor

**NEW  
LOCATION  
Tucson, AZ  
520•322•5625**

Vancouver, B.C.  
604•253•0017

Circle 232 on Rapid Reply

**CCTV • SAFES • DOOR HARDWARE • ACCESS CONTROL  
SECURITY PRODUCTS • LOCKSMITHING TOOLS**



22 Carefully pry the trim from the front edge and slide it away from the handle.



23 With the trim piece removed, a small screw is visible. Remove the screw.



24 Remove the rest of the screws that can be found around the perimeter of the panel.



25 Three of these screws can be found along the bottom of the panel.



26 Once complete, pry the door panel off of the door.



27 Plastic clips hold the door panel in place, and it may need a little coaxing. Be careful not to break the clips or the clip holders

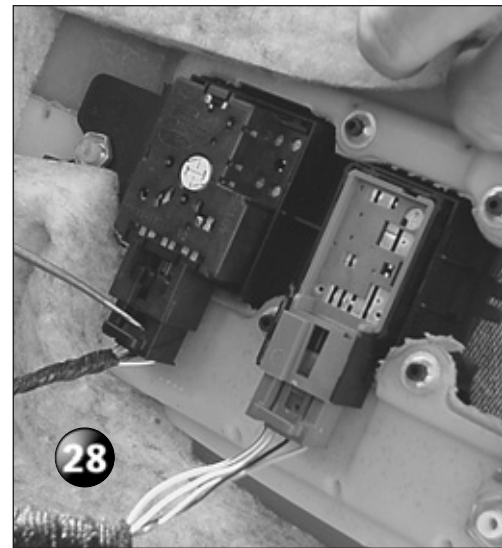

28 Once the panel is loose from the door, carefully remove the various electrical connectors. Two can be found up near the side door handle area.

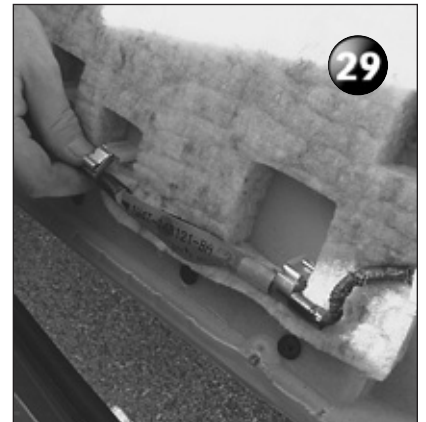

29 An interior floor light can be found near the bottom left of the panel. This harness of this light connector includes several strain relief clips.

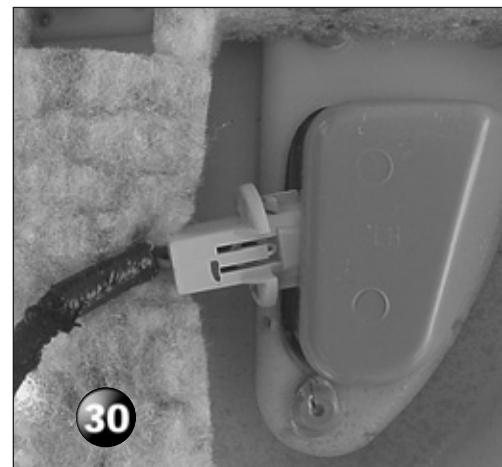

30 Remove these clips before disconnecting the light. Set the door panel aside.



# THE HINGE DOCTOR

Are your doors **SAGGING? DRAGGING?  
RUBBING?**

**The Hinge Doctor will adjust them in seconds!  
No other tools needed.**

"I used mine twice in the last week. It really impressed my customers that a "little girl" like myself could repair a big ol' steel door by myself! I never let them see my secret weapon, I let them assume that I had to take the door down and do all sorts of work to it!" -- Melanie Long, Lock Stock & Barrel



**HA1** For  
Standard  
Commercial  
4-1/2" x 4-1/2"  
Butt Hinges



**HA3**  
For Ball-  
Bearing &  
Larger  
Commercial Hinges

US Patent  
#6450003

**HA4**  
For Prison  
& Institutional  
Hinges & Standard  
Spring Hinges



**NEW**

**HA2** model  
fits most residential  
hinges. Fully adjustable.

Over **10,000**  
Satisfied  
Customers

**800-924-5397**  
[www.hingedoctor.com](http://www.hingedoctor.com)

by GKL Products  
(a division of Gold Key & Lock Co. LLC)

# TECHNTIPS

## YEAR-END PRIZES



**Grand Prize**

*Silca Bravo Duplicator*



**1st Prize**

*HPC's 1200PCH  
Punch Machine*



**2nd Prize**

*Kaba Mas  
PowerLever 2000*



**3rd Prize**

*SDC Magnetic Lock,  
Keypad and Exit Switch*



**4th Prize**

*Securitron 12-Volt Unlatch Plug in  
Trans & Touchpad Retail Value \$650*



**5th Prize**

*LaGard "SmartGard"*



**6th Prize**

*Detex Advantex*



**7th Prize**

*Arrow 400 Series Alarmed  
Exit Device & S-75 Mounting  
Plate Kit for Narrow Stile  
Aluminum Doors*



**8th Prize**

*\$500 in ASP Auto Locks*



**9th Prize**

*\$500 in Strattec Auto Products*



**10th Prize**

*Tech-Train "Jiffy Jack"*



**11th Prize**

*Sargent & Greenleaf 6120  
Electronic Safe Lock*



## Prizes Awarded From These Companies Every Month!

*A-1 Security Mfg. Corp.*

*High Tech Tools*

*HPC, Inc.*

*Jet*

*Kaba ILCO*

*Keedex, Inc.*

*LaGard, Inc.*

*Lockmasters, Inc.*

*Major Mfg.*

*Sargent & Greenleaf, Inc.*

*Sievekings Products Co.*

*STRATTEC Security Corp.*

*Wedgeco International*



**12th Prize**  
High Tech Tools  
2004 Pro Set

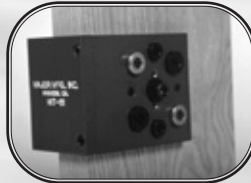

**13th Prize**  
Major Manufacturing's  
HIT-111 Drill Guide



**14th Prize**  
Baxter #90 10-Cut  
GM Try Out Key Set



**15th Prize**  
Sievekings Products  
Squeeze Play

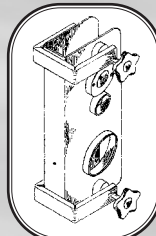

**16th Prize**  
A-1 Security  
Manufacturing  
Installation Jig



**17th Prize**  
Keedex Sampler

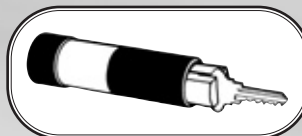

**18th Prize**  
Framon  
Impressioning  
Handle



**19th Prize**  
Gator Tool Multi-Purpose  
Facecap Tool

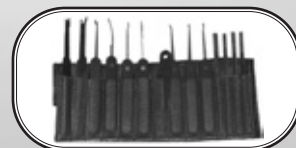

**20th Prize**  
Peterson Picks,  
by Peterson Manufacturing

## E-MAIL YOUR TIPS AND WIN!

[Natlock@aol.com](mailto:Natlock@aol.com)

### Send in your tips, and win!

#### How To Enter

Send a tip on how to do any aspect of locksmithing. Certainly, you have a favorite way of doing something that you would like to share with other locksmiths. Write your tip down and send it to:

*Jake Jakubowski, Technitips Editor,  
The National Locksmith  
1533 Burgundy Parkway  
Streamwood, IL 60107-1861*

**Or send your tips via  
E-mail to: [Natlock@aol.com](mailto:Natlock@aol.com)**

#### Rules & Regulations

Each tip submitted must include your full name, street address (no P.O. Box numbers), city, state, zip code, phone number, fax number and e-mail address. **When sending tips via e-mail make sure to include complete address and phone.**

#### Every Tip Published Wins

If your tip is published you will win one of the monthly prizes listed. At the end of the year, we choose winners from all the monthly tips published, that will be awarded one of the fabulous year end prizes. All you have to do to win is enter.

Prizes are arranged according to suggested retail price value.

Tips Start  
on Next Page

**Prizes  
Awarded From  
These Companies  
Every Month!**



**Kaba ILCO**



**Sargent &  
Greenleaf  
Sieveking  
Products Co.**



## **A Few Words From Jake...**

Had a reader call me up a while back and wanted to know how come so many of the tips he read were submitted by the same person. The reader went on to say that it seemed like the same people were in the column more frequently than others on a regular basis.

I said to that caller, "You noticed that, did you?" Why do you think so many of the same names appear under tips month-after-month?"

After a little throat-clearing and a few "Uh, well, uh..." and "Well, uh...I, uh"; he mumbled that he thought it might be because they sent in more tips than other folks did.

Yep! The answer is simple. Over a given period of time, the names that chronically appear under tips in this column are the names of locksmiths who know a good thing when they see it. So, they take the time to sit down, jot down their ideas and send them in for consideration...and usually end up winning a prize.

Besides getting a prize the month the tip appears in the magazine, they have a good shot at a year-end prize when we make our year-end drawing.

On the other hand, I've had tipsters send me a tip, it didn't get published and they later called and wanted to know why. Again, it's simple: If I can use a tip I will—if I can't, I won't. So if one tip doesn't make it into the column, maybe the next one will.

If you've submitted a tip and it didn't get in the column, submit another...and another...and another, if necessary. One of those tips has to make it. The law of averages says so. But, if you don't send a tip to me, I can guarantee you that you'll never see your name under a tip in this column—don't you agree?

So, write the idea down. Draw a diagram if you like...and send it in! That's the only way you'll ever come close to winning a prize.

In the meantime, let's look for each other at ALOA.

See y'all next month!



*by Jake  
Jakubowski*



### **Ford Pick-up Spare Tire Key Trick**

If you need to cut a Ford spare tire key and find that the key is too long to fit in your key machine, you can make a home-made key that will work as good as the original and can be cut on any key machine.

Go to any garden center and get a round plastic rod used to stake tomatoes. Cut off six inches of the rod, and then cut a slot in the end of the six-inch piece. Next, take an X-7 key blank and file or grind the sides off the head of the key. Drill two holes into the rod. Then drill two holes into the cut down key blank.

You can now copy the customer's key, use two small screws and two nuts to fasten the key to the rod. I put a key ring

**Continued on page 102**



LOCKSMITHS WHO DEMAND THE BEST  
**DEMAND**  
 WWW.DEMANDA1.COM

# A1

If you're looking for caps and t-shirts, forget A1.

If you're looking for top-flight original equipment and innovative tools

**PAY CLOSE ATTENTION!**

## EXCLUSIVE NEW PINNING KITS



## ORIGINAL EQUIPMENT IGNITIONS

LeSabre '00 & Up/CTS '03 & Up **#8328** (pictured)  
 Grand Prix '04 Ignition Uncoded **#7297**  
 Malibu '04 Ignition Uncoded **#8722**  
 Bonneville '00 & Up/Aurora **#8492**

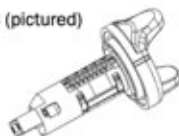

## NEW SPECIALTY TOOLS



**Fighting Wedge.** Release valve and fortified double seams. Competitively priced. **#43**



**Magnum Pick Gun.** 5-year unconditional warranty. Includes 3 tips and tension wrench. Disassemble for easy maintenance. **#44**

**Bulls Eye Installation Tool.** Drill 1-1/2" and 2-1/8" cross bores. Automatic backset adjustment. Uses conventional hole saws. **#BUL-2**



**Quickpull 2.** For Schlage 'F' Series locks. Now pull locked knobs from the front. **#QP-2**

## A1 ORIGINAL KEY BLANKS



Ford 10-cut key blank  
 Ford logo **#H67-PH**



Ford 8-cut key blank  
 Ford logo **#H75-PH**



Cadillac CTS/Cad. logo  
 PK3+ X'ponder/On-Board  
**#GMX-320**



Grand Prix '04/Pontiac logo  
 PK3 X'ponder/On-Board  
**#GMX-367**



Cadillac SRX '04/Cad. logo  
 PK3+ X'ponder/On-Board  
**#GMX-265**



Chevy Malibu '04/Chev. logo  
 PK3+ X'ponder/On-Board  
**#GMX-380**



LeSabre '00 & up/Buick logo  
 PK3 Transponder (B99)  
**#GMX-220**



Bonneville '00 & up/Pontiac logo.  
 PK3 Transponder (B99)  
**#GMX-310**



Chev. Colorado/Chev. logo  
 Plastic Head (B110) **#16652**



GMC Canyon/GMC logo  
 Plastic Head (B110) **#16653**

## TRANSPONDERS



Ford Transponder  
 On-Board Programmable  
**#S72**



Ford Transponder  
 On-Board Programmable  
**#S86**



Honda Transponder  
**#HD106-PT**



Toyota Transponder/On-Board  
**#TOY43-AT4**



GM Small Head  
 Transponder/On-Board  
**#B97S-PT**



GM Large Head  
 Transponder/On-Board  
**#B99S-PT**

## VATS ORIGINALS



Single-sided  
 GM-201 through GM-215



Double-sided  
 GM-772 through GM-785

## SOMERSET VATS



Single-sided  
 201-S through 215-S



Double-sided  
 202-S through 785-S

## CHRYSLER ORIGINALS



Chrysler Transponder/  
 Chrysler logo  
**#Y160CHY-PT**



Chrysler Transponder/  
 Jeep logo  
**#Y160JP-PT**



Chrysler Transponder/  
 Ram logo  
**#Y160RAM-PT**



Chrysler Transponder/  
 Pentastar logo  
**#Y160PEN-PT**

CALL US TOLL-FREE 1.877.725.2121 FOR TECHNICAL INFO

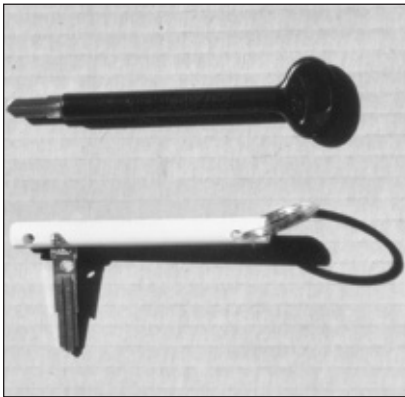

Photograph 1.

into the other end to make it easy to turn (see photograph 1).

Anyone that doesn't want to make their own can buy them from *Hawley Lock Supply*.

*Lamar McCrider  
South Carolina*



**- WINNER -**

**Cabinet/Locker Rekey Trick**

Did you ever have a customer bring in a "T" or "L" handle lock found on metal cabinets and lockers to be rekeyed? Then when you started to remove the plug, you found it didn't have a poke hole to depress the retainer and release the plug?

This meant you were going to have to either drill a hole to access the retainer, or you would have to try to fish the retaining wafer down with a bent wire, or hook. Here's a way I've found to re-key the plug without having to drill a poke hole.

Duplicate the customer's working key. Put the key into the plug and clamp the bow of the key very tightly in a vise. Work the handle back and forth from the locked to the unlocked position while pulling straight back on the handle very hard! The cylinder will pop out (trapped on the key in the vise) with no

damage. The back and forth motion, while pulling back on the handle puts pressure on the retainer and allows it to release.

This technique will only work on cylinders that trap the key. If the cylinder is keyed 3337 or 1234 (bow to tip) or similar cuts, the lock will simply pull off the key. It will work very well on cylinders keyed to 4321 or 4242 or a multitude of similar cuts that trap the key.

This technique will not, so far as we have seen to date, damage the lock or the retainer. Simply depress the retainer and snap it back together.

*Jerry Sullivan  
New Jersey*



**- WINNER -**

**Potpourri—Four for One**

This is a compilation of tips from the last few jobs I did.

I had to install an electric strike to a rosewood door. Not wanting to damage the door and to cover any possible slips, we checked with maintenance and found they had some of the original stain for the door. We touched up all marks before we started and then stained the edge of the strike prep so that no raw wood was visible when the strike was installed. The result was a clean low visibility install.

On an installation to a Duronodic frame, we touched up the edge of the cut outs with a black "Sharpie" magic marker. Again no raw aluminum was exposed and the install looked a lot cleaner.

When installing small diameter Ilco, Timberline, or ESP furniture locks where there is no trim collar, drill the face of the material with a 5/8" Forstner



bit to a depth of 1/8". Then, counter-bore from the back of the drawer/door with a 11/16" or 3/4" Forstner bit. Touch up the edges of the cut with black marker and install the lock. The face is a nice close fit and no raw wood is visible.

In each of the above cases the customer was extremely pleased with the effort we took to do a clean install.

*Martin Brown  
Canada*



**- WINNER -**

**Let There Be Light**

Third hands come in all shapes and sizes. I've found one that I'd like to share with you.

This little jewel is called "Nite Ize" and can be found in various auto parts stores, hardware stores and big box stores (see photograph 2). If it does nothing else, it will keep your MAG® Silhouette flashlight where you can find it when you need it.

What I find is, that when I'm under the dashboard of a car working on the ignition, I can grip the Nite Ize between my teeth and direct the beam of light wherever it will do me the most good. And, if I drop it, the lanyard is around my neck so I don't have to get out from under the dash and hunt for a light that might otherwise have rolled under the seat.





**Photograph 2.**

As you can see by the illustration, the Nite Ize is designed to accept a MAG® Silhouette light, or a similar product and keep it close by hanging around your neck.

If you can't find one in your local area, call or write, NITE IZE INCORPORATED, 5735-E Arapahoe Ave., Boulder, CO 80303.

*Dennis Harmon  
Colorado*

# Sargent & Greenleaf

**- WINNER -**

## **Sentry 3810 Opening Trick**

This is a trick I've used to get into a Sentry model 3810 fire safe.

This safe had been burglarized, but not opened. The safe was brought to me with the front panel dangling by the wires.

*Illustration 3*, is a sketch of the display board minus, the keypad, which was missing. Notice that to the left of the top row of contacts (1-0), there is a row of contact points soldered. The 3rd and 4th contacts are the ones which are needed to open the safe by releasing the solenoid,

and allows the handle to be turned downward to open the door.

Use the battery pack if still there. If not, set up a battery pack with 4 AA batteries and a wiring harness. Use the red wire or (+) to the post indicated, and the black wire to the (b) simultaneously. While holding the contact, push the handle downward (Or, have a helper do it), and the door will open. If the solenoid does not trip, try reversing the wires.

The illustration is used to depict the solder points to use for opening. If the board is ripped off

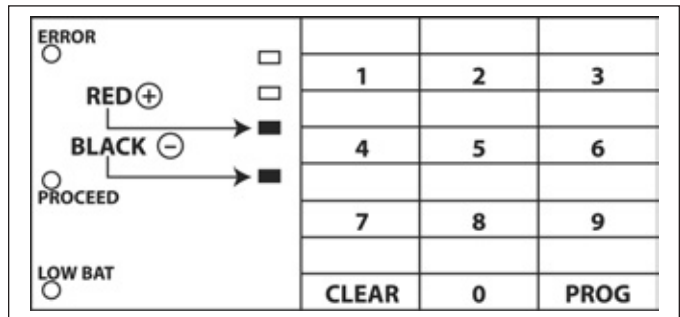

**Illustration 3.**

# **OSI Security Devices Inc.**

1580 JAYKEN WAY, CHULA VISTA, CA 91911  
 PHONE: (619) 628-1000 / FAX: (619) 628-1001  
 WWW.OMNIOLOCK.COM

Cylindrical **OMNIOLOCK OP2000** Keypad-and Proximity Standalone Reader electronic locks control access for up to 2000 users and install easily like all other OMNIOLOCK systems. All OMNIOLOCK Cylindrical locks install into existing door preparations without the need for any additional hole drilling. The OP2000 offers an audit trail of 50,000 events, 256 time schedules with 32 Holidays each, and is available in Grade1 Cylindrical (Schlage D-lock shown at right), Mortise, Wall Mount System, Quick Adapter for use with existing Schlage locks, and Exit Device Adapters.



**OMNIOLOCK Exit Device Trims** are designed to be used with new or already existing Exit Devices. These trims are available in keypad-only, magnetic stripe card reader-and-keypad (at right), or in HID proximity card reader-with-keypad configurations. These trims adapt to new or already installed Von Duprin, Precision, Corbin-Russwin, Yale, Sargent, and Arrow Rim Exit Devices without drilling ANY new holes in your existing door. They also adapt to Vertical-Rod Exit Device.

like the one I had, and there are only 2 wires sticking out of the door; simply use your battery pack to touch the red and black wires to the white and black wires protruding from the door and lower the handle.

*Fred Spencer  
Pennsylvania*



**- WINNER -**

**Herman Miller Furniture Lock Trick**

I do a lot of work on Herman Miller furniture locks.

I'm sending a sample of one that is commonly found on their horizontal file cabinets. These locks have a pull out core/plug (see photograph 4). It is suggested that to remove the core, you use a hook to release the retainer. I have found a better way to remove these cores than using the hook game.

So far, all of these locks start with an "LL" or a "UM" code and have a retainer ring in the sixth wafer position. I create a sixth position on a Y-11 blank by cutting the shoulder back and then shortening the tip so it doesn't extend past the end of the plug.

I file a little in the newly created 6<sup>th</sup> position—just enough to raise

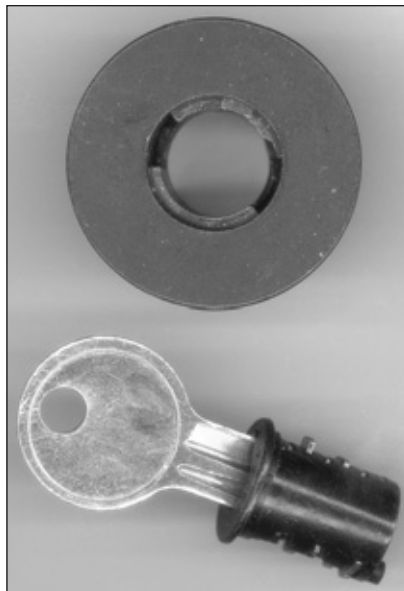

**Photograph 4.**

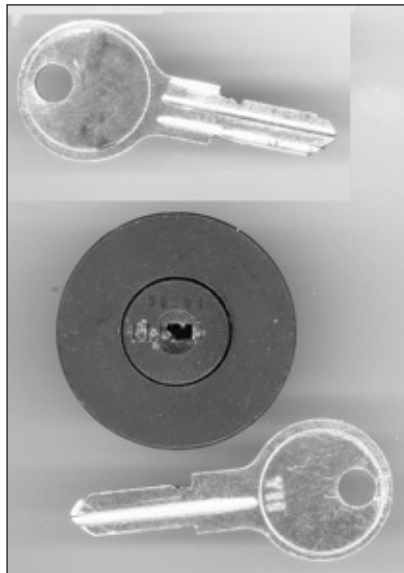

**Photograph 5.**

the retainer ring to the shear line. I make two of these keys, one with no cuts for reinserting the plug (see photograph 5). This key will also pull the easy ones. I cut the

other one with a shallow trap cut in the first position for the stubborn ones.

So far, they've all succumbed to either one, or the other of these keys. It sure beats bending hooks.

*Dennis Gillette  
Illinois*

**ILCO**  
**- WINNER -**

**Pin/Wafer Reader Trick**

I'd like to share an easy way to quickly figure out the tumbler sizes in a wafer or pin tumbler lock.

Simply make a set of depth keys with the depth number on them starting with a zero, or "1" depth (depending on the brand your dealing with) and moving progressively to the deepest depth in that series. Just make sure that you only cut one depth on each key. In other words the KW-1 would have one key with all number one cuts, a second key with all number two cuts and so on. Stamp each key with its respective depth.

In the examples in photograph 6, I have shown (clockwise) a KW-1, a Y-11, a Y-13 and a SC-1. You can make your keys up using the most common keyways you deal with on a regular basis.

After shimming the cylinder and removing the plug, just

**INTERCHANGEABLE CORE PRODUCTS**

Interchangeable with:

- **BEST**
- **ARROW**
- **FALCON**

Quality • Price  
Delivery  
*That's what KSP is all about!*

**KSP**  
**KILLEEN SECURITY PRODUCTS**  
33 Hermon St.  
Worcester, MA 01610  
Phone (508) 798-3200  
Fax (508) 753-2183

Ask your wholesaler about our drop shipping.



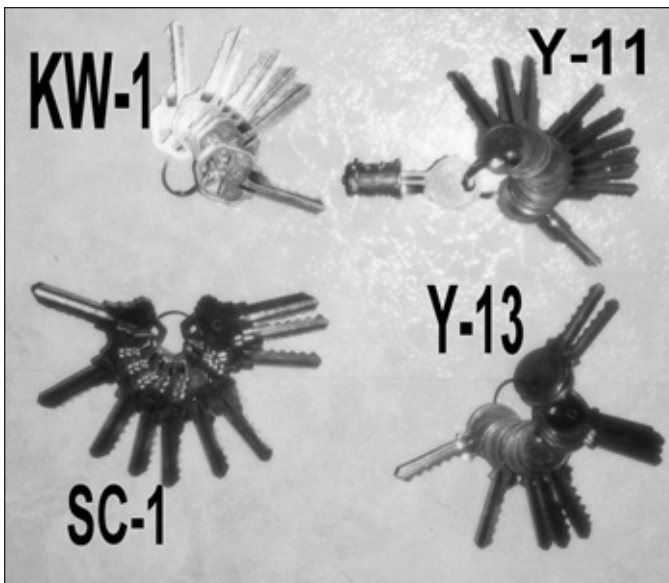

**Photograph 6.**

insert the keys one-by-one and determine the depths in each chamber. Make note of the depths and code cut a key for that cylinder. I find this much easier than removing and measuring each pin or wafer.

*Larry Bors  
Oklahoma*



**CONTICO Tool Box Keys**

I had a customer that needed keys for a truck toolbox that had "Contico Tuff Box" on the lock. I called Contico to see what blank it used, because I couldn't find a blank to work. They said that they would only sell the keys to the end user at \$2.00 per key.

I thought that was cheap enough, but my customer was heading out of town and needed them right away. I tried to fit some new blanks from TriMark that I ordered from Ilco and one matched the Contico lock. I used the Ilco 1623, EZ #TM15. They im-

pression fairly easy and the one I made was mostly shallow depths.

*Frank Kitchen  
Indiana*



**ACE® Tubular Key Trick**

Last weekend I received a call from a Harley-Davidson rider. He had run out of gas and had to push his bike over a mile to get to a gas station. At the gas pump he realized that he didn't have a key to his gas tank. He had just bought the bike and the previous owner did not give him a key to the tank.

The switch had a standard single-sided key, but the gas tank

**E-MAIL YOUR TIPS  
AND WIN!**  
*Natlock@aol.com*

had a tubular lock that used the 137B blank. I had my tubular pick in my hand and was about to pick the lock when for some reason I put a key blank into the lock just to make sure that I had the right blank.

The lock turned to the open position using only the uncut key blank. By this time some of his biker's friends had arrived. Just to satisfy my curiosity, I tried the key blank in a couple of the other bike's gas tanks that had tubular locks. It turned all of them. I don't know if this will work on all of the tubular gas tank locks on Harley's, but it has worked on the ones I have tried.

I have to tell you that I'm sure glad it worked that way, because this guy was no fun to be around.

*Luke McCrider  
South Carolina*



**Free Door Opening Tools**

Every week I receive credit card and Office Max solicitations in the mail. Enclosed with these

**Buddy Products** *The Best in* **HOME & OFFICE SECURITY**

Put your mind at ease...Secure your valuables and important documents with top of the line security products from **Buddy!**

**Key Cabinets** - Item # 0128  
Chicago, IL

**Cash Boxes** - Item # 0513  
Customer Service 800.886.8688

**Security Boxes** - Item # 0515  
Fax: 312.733.8356

**Wall Safes** - Item # 3100  
www.buddyproducts.com

solicitations are credit card sized plastic cards. I have found that they are just the right gauge material to shim doors open, and they are more flexible than a standard credit card.

If the door has thick weather stripping or a 1/4" gap in the door, you can insert the card by the latch, then pull the door toward you and push on the card. The dead latch will fall into the strike plate hole and you simply have to push on the card with more force for the door to open. If a little more tensile strength in the card is needed, you can slip another card on top of the already inserted card to force the latch back.

*Dave Boemer  
Coeur d'Alene*



#### **Dead-on Deadbolt Strike Locator**

In this area I get a lot of calls to install deadbolts in existing hollow metal doors/frames. To assure a good fit and smooth bolt throw, I made a marking device from an old deadbolt latch (one without the hardened insert).

I cut about 5/8" of the tip off a hardened nail to use as my scribe. Next, I drilled a hole into the dead center of that bolt just slightly more than 1/2" deep, so that slightly less than 1/8" of the point will stick out of the end of the bolt, then I epoxy it in place.

After prepping my door edge with a Squeeze Play or Major Manufacturing's *Lock Mounting Brackets*, I install my modified bolt. With the door properly seated in the frame, I use a straight-blade screwdriver to throw the bolt until it hits the metal jamb. While holding tension on the screwdriver, I gently pull the door open about 3/8", and then turn the bolt

back to the unlocked position.

When I open the door there is a small scratch mark on the frame, starting at the center of what will be the strike hole. At that point, I drill a 1" hole on the center point, install a thimble strike and have a perfect fit for the new deadbolt. This works equally well on wood doors and frames. On frames filled with mortar, save your hole saw by cutting only until you have the metal cut, then finish the hole with a masonry bit.

*Bob Roman  
Maryland*



#### **Twenty Second Safe Opening**

A cheap electronic safe model sold by a national discount tool house for around \$40.00 has become very popular in my area, and I suspect other parts of the country as well (see *photograph 7*).

The safe is labeled GORDON and has SKU #P45891 on the front beside the keypad. If the safe is locked but operational, it can be opened in approximately 20 seconds with no damage by simply resetting the combination and unlocking it as normal.

To reset the combination with the safe locked, begin by using a screwdriver or metal dowel that will enter the upper left factory holes in the back of the safe. The combination change button is located on the edge of the lock housing nearly straight across from this hole. Push the dowel or



**Photograph 7.**

screwdriver 9-1/2" into the safe and locate the button by feel. It is easy because it is the only thing protruding from the lock housing on the hinge side.

Push the combination change button until the lock beeps. The direction to push is into the lock body away from the hinges. After the safe beeps release the button then enter four numbers and push the "A" button. The combination has been reset.

Enter the new combination, push the "A" button and rotate the thumb-turn to retract the two bolts within 5 seconds. The safe is open, the combination is reset and you are ready to collect your fee.

Take this opportunity to sell your customer a quality safe for their valuables, and explain that discount safes are definitely for low cost items that need minimal security only.

*Bob Floyd  
Arkansas*





# Time Saving Tools

## The "PIT BULL" Metal Door Latch Tool

Install cylindrical locks and deadbolts in metal doors with professional results. The **MDLT-1** "PIT BULL" will form a rectangular indentation for a 1" or 1-1/8" latch face.

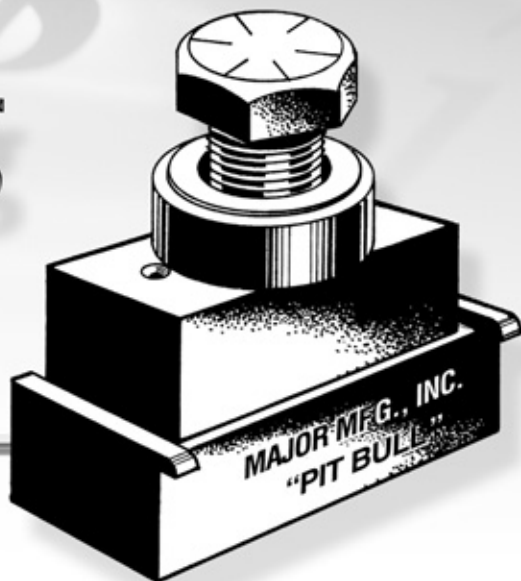

## MDPS-4 & MDPS-6 Punch & Die Sets (For Metal Cabinet Lock Installations)

Punch "Double D" holes in sheet metal cabinet doors and drawers with our MDPS series punch and die sets. Choose from two sizes, the **MDPS-4** for standard cam locks or the larger **MDPS-6** for ASSA pin tumbler cam locks.

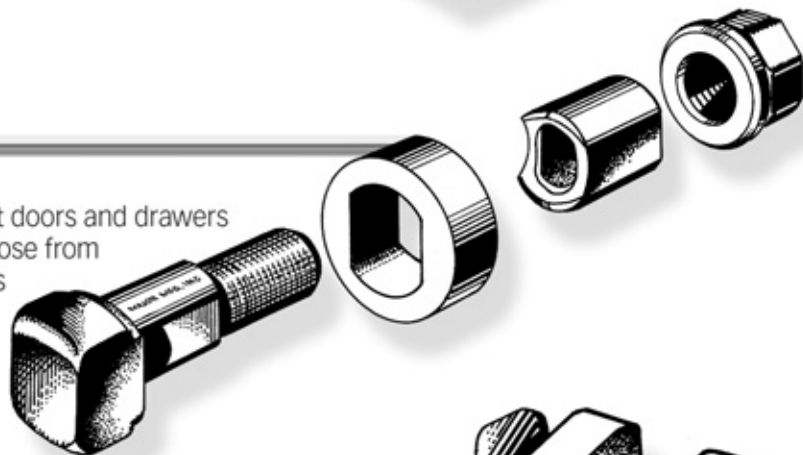

## HIT-25 Cabinet Lock Drill Guide

Our **HIT-25** Cabinet lock Drill guide includes many important features:

- Five sizes of drill guide inserts 3/4", 7/8", 1", 1-1/8" and 1-1/4".
- Rubber lined jaws to protect finished doors and drawers.
- An adjustable sliding stop for repeat installations.
- The HIT-25 has a door range up to 1-1/2" thick and will accommodate backsets up to 2-5/8".

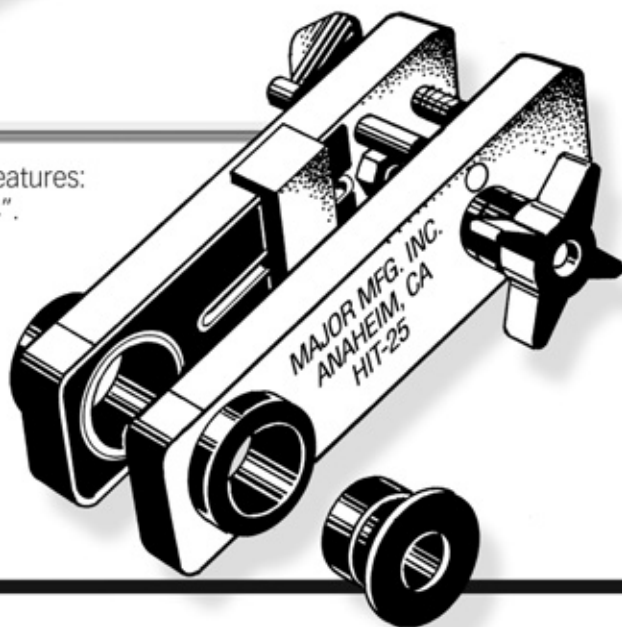

# Major

MANUFACTURING, INC.

1825 Via Burton • Anaheim, CA 92806 • 714-772-5202 • Fax 714-772-2302 • [www.majormfg.com](http://www.majormfg.com) • [mail@majormfg.com](mailto:mail@majormfg.com)

Circle 249 on Rapid Reply

# 2008 BMW F650GS

by  
John  
Blankenship



**1. The F650GS is a deluxe dual-sport motorcycle with a 650cc single cylinder engine. The gas tank is under the seat so the gas cap is located on the right side of the seat. It is a good lock to originate a key from.**



**2. The dust cover is raised showing the gas cap in the locked position.**



**3. The gas cap has been picked and is ajar. This lock was easily picked counter-clockwise by bouncing a rake between the wafers on top and bottom of the keyway. You are picking against spring pressure so have a small screwdriver ready to finish turning the plug. The plug does not hang up in this position when a key is used; the spring returns it to the locked position. Do not disassemble the lock with the plug in this unlocked position or the spring-loaded tailpiece will pull out of the lock plate. The plug is very easily picked back to the locked position; just touch the rake to the wafers and it springs back.**





**4. Stuff a clean rag into the filler neck so nothing falls into the gas tank. Then remove the three Phillips screws and remove the lock plate.**

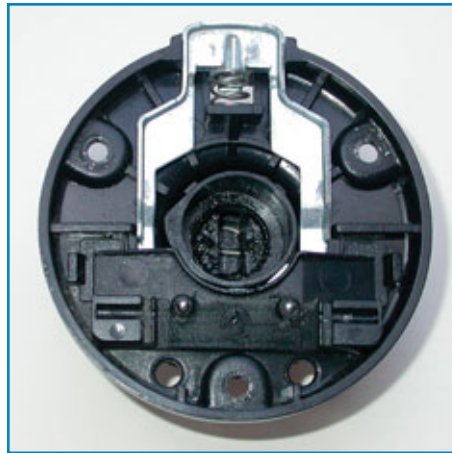

**5. The lock plate is removed from the gas cap. The spring-loaded tailpiece is in the center and is a little tricky to replace if it comes out.**

**6. The wafer retainer is on the upper side of the plug. Depress it and push the plug out the front. Be careful and do not allow any of the wafers to fall or spring out.**



**BUSCH**  
 The Key Machine Superstore  
 Discountkeymachines.com  
 800-332-8724

Tradition of  
 Innovation  
 for over two centuries

The ideal high security  
 key cutting solution  
 for automotive  
 professionals.

Bianchi 303

**BIANCHI**  
 USA, Inc.

Circle 109 on Rapid Reply

**WE STOCK  
 RIXSON, RIXSON AND  
 MORE RIXSON.**

**R**

**MAYFLOWER**  
 800-221-2052 [www.mfsales.com](http://www.mfsales.com)  
 INMETRONYC/718-622-8785 FAX/718-789-8346 EMAIL/pilgrim@mfsales.com  
 ASK FOR YOUR FREE COPY OF OUR NEW CATALOG.

Circle 254 on Rapid Reply

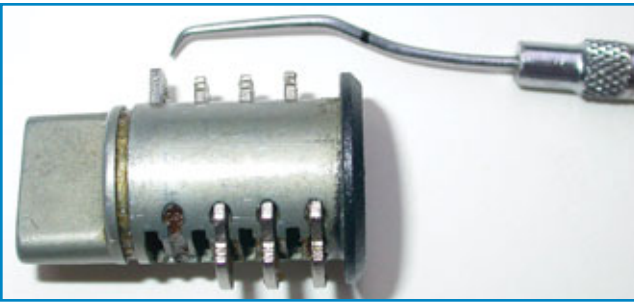

**7.** The gas cap plug contains six wafer tumblers and a wafer retainer. The tumblers are staggered on both sides of the keyway with the even space numbers on top and the odd space numbers on the bottom. When the gas cap is closed, the top will be toward the rear of the motorcycle. The tumblers are in the first six chambers, the seventh chamber is empty, and the retainer is in the eighth chamber. The retainer is closed on the bottom, so it can be depressed by using a dental hook pick in the keyway so you can avoid disassembly. The retainer is 3/4" (19mm) from the face of the plug. Put a mark 3/4" from the tip of the pick to aid in locating the retainer.



**9.** The gas cap wafers are from left to right, 213133. They are stamped with the depth number but the numbers face the rear of the keyway so you cannot see them when looking into the keyway. You can use the ASP A-13-101 keying kit, which is also used by 1975-1993 BMW automobiles that use the 'HB' codes and X59 or X144 blank. You can determine the cuts for spaces 7 & 8 in the ignition lock by using code software, progression or impressing. Software: A search using software revealed that there are only two codes that use those cuts in the first six spaces so the last two cuts can only be 12 or 23. The code turned out to be H23422P with cuts of 21313312.

Progression: Only 3 depths are used so there are only 9 possible combinations for progressing cuts 7 & 8. 1st key: 11, 12, 13, 23, 33. 2nd key: 21, 31, 32. 3rd key: 22.

Impressing: The wafers are sturdy so impressing is a good option.



**11.** A code cut X59 with cuts of 21313312 works all three locks smoothly. The original key is on the bottom.

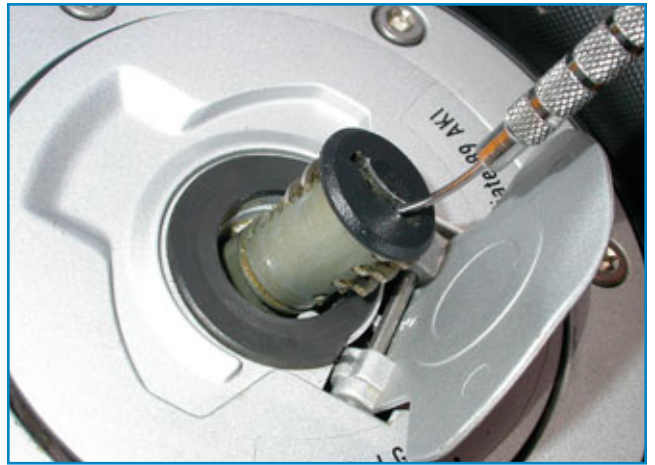

**8.** Work the pick into the keyway until the mark is even with the face of the plug. When you are on the retainer you can feel the spring tension as you pull it down (toward the front of the motorcycle). The pick will extend into the lower wafer chamber enough for you to pull the plug out once you have it depressed. A standard hook pick will not work because it does not push the bottom of the retainer down into the lower wafer chamber far enough.



**10.** Both of these blanks will work. A Silca BW7BP is on the left and an Ilco X59 is on the right. An Ilco X144 will also work.



**12.** The rear compartment lock is also a good lock to originate a key from.



# ITL 950C

MOBILE CODE MACHINE

The only machine  
that does it all in  
less time for  
less money!

## Codes Codes Codes

Most Domestic, Japanese, and  
Korean Car Codes are now built in.



- Windows™ interface for built in Masterkey system printing and saving
- Domestic car codes included
- Both 12 volt and 120 volt usage standard
- One cutter emulates all flat widths
- Four line display with menus
- RS232 communication port
- Repeatable accuracy +/- .002
- 1 year parts and labor warranty
- Over 500 manufacturers depths and spaces built in
- Finds, loads and cuts a car key in 15 seconds

Call for introductory Video  
888-264-6627

The new ITL 950C:  
the most cost  
effective code  
machine ever!

Phone: (888) 264-6627  
(604) 852-8904  
USA: (562) 699-0060

**INTRALOCK**  
TOOLS LIMITED

2639-B Progressive Way  
Abbotsford, B.C.  
V2T 6H8

[www.intralocktools.com](http://www.intralocktools.com)

Serving industry with superior key machines since 1985.

Circle 234 on Rapid Reply



13. The rear compartment lock has just been picked 90 degrees clockwise. This lock was easy to pick by bouncing a rake between the wafers on top and bottom of the keyway.



14. After you unlock the rear compartment, slide the cover forward and you can lift it off.



15. The tailpiece is held on by a roll pin.

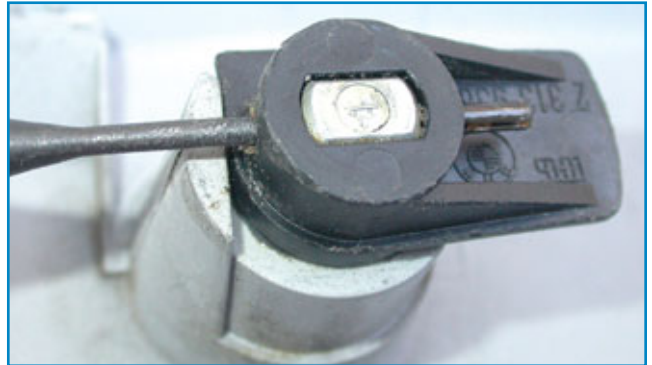

16. Use a 3/32" punch to drive out the roll pin.

17. The rear compartment plug contains six wafer tumblers and a wafer retainer. The retainer serves no function that



I can determine. The tumblers are in the first six chambers, the seventh chamber is empty, and the retainer is in the eighth chamber. These tumblers are numbered per depth just like the ones in the gas cap.



18. The Determinator™ for BMW automobiles works well on the rear compartment lock. The spacing and depths are the same as the automobiles except BMW motorcycles do not use the fourth depth.

The tool will hang up on #3 depth tumblers and since there are no #4 depth tumblers, you know it is a #3 if it hangs up. Note: The tool hung up on the #2 depth tumbler, but it pulled loose when I wiggled and pulled on it. It would not pull loose from the #3 depth tumblers. There is grease in the lock so use a spray lube with the tube inserted into the keyway and then rake the wafers to free them up. The tumblers are staggered on both sides of the keyway with the even space numbers on top and the odd space numbers on the bottom. The Determinator™ will also work on the gas cap, but it is a shorter lock and the space numbers on the tool will not read correctly. The ignition lock has so much grease that I could not get good readings. I recommend using The Determinator™ in the rear compartment lock and then use software or a progression process to find the cuts for spaces 7 & 8 in the ignition lock.



19. This view from the drivers' seat shows the ignition/steering lock located in front of the handlebars.





20. The ignition/steering lock is shown in the "R" or ignition off position. A slight turn clockwise turns the ignition to "ON" and turning it 90 degrees counter-clockwise turns it to "P", which turns on the parking lights and locks the steering. Turning it farther counter-clockwise to "OFF" turns the parking lights off and leaves the steering locked. The steering must be turned to the right or left in order to lock the steering. The steering lock bolt can bind when trying to unlock it; wiggling the handlebars frees it so the lock will turn.



21. The ignition lock plug is removed by turning the ignition "ON" and depressing the retainer through the poke hole. The rectangular poke hole is located on the front of the lock just above the round detent spring retainer and just to the right of the center rib. You need to turn the steering all the way to the left in order to use a punch as shown in the photo.

## The Desktop Dispatcher

Track your calls on your computer.

- **Create it.**
- **Track it.**
- **Print it.**
- **E-mail it to techs.**
- **Store it to build service history.**
- **Invoice it.**

See us at  
ALOA  
Booth 813

Starting at \$250.00

For more info and a free demo call 561-714-5240

or visit

[www.DesktopDispatcher.com](http://www.DesktopDispatcher.com)

IS YOUR SUPPLIER FRIEND OR FOE?

WERE YOU AWARE THAT SOME SUPPLIERS ARE COMPETING AGAINST YOU? AT MIDWEST WHOLESALE HARDWARE WE DO NOT SELL TO END USERS. OUR SOLE BUSINESS IS FRIENDLY WHOLESALE DISTRIBUTION.



**MIDWEST WHOLESALE HARDWARE**

Visalia, CA  
833 767 8527

Kansas City, MO  
800 824 8527

Orlando, FL  
800 650 8527

[midwestwholesale.com](http://midwestwholesale.com)



22. The ignition lock uses the same plug as the rear compartment lock, but it is set up differently. It contains all eight wafer tumblers with the odd spaces on the bottom and the even spaces on top. The retainer and spring fit into the hole that is used for the roll pin when this plug is used in the rear compartment lock. There is a lot of grease in this lock that makes using The Determinator™ difficult.

**Codes: H12353P-H53425P**

**Blank: Ilco X59 (BMW2) or X144 (BMW3), Silca BW7BP**

**Spacing: 1=.106, 2=.189, 3=.272, 4=.354, 5=.437, 6=.520, 7=.602, 8=.685**

**Depths: 1=.327, 2=.303, 3=.280**

**HPC Card Number: XF33**

**ITL Number: 62**

**Tumbler locations: 1 2 3 4 5 6 7 8**

**Ignition: XXXXXXXX**

**Gas Cap: XXXXXX**

**Rear Compartment: XXXXXX**

**Ignition: 1-8**

**Gas Cap: 1-6**

**Rear Compartment: 1-6**



23. The ignition lock wafers from left to right are depths of 21313312 and are numbered per depth. These are different than the wafers in the other locks. However, you can buy service kits for the locks on this bike that include the plug, retainer, springs, and enough wafers to key the lock to any code. They are available from the parts department of BMW motorcycle dealers. 



## Will your door repair last through every resident of five states?

Every resident of Maine, Vermont, New Hampshire, Massachusetts – and Wyoming – could walk through your repaired door equipped with SELECT Hinges™ and not wear it out.

That's because a SELECT Hinge has lasted more than 10 million cycles (and counting) in an independent lab test on an FRP door. No more sagging, dragging, unattractive and hard-to-use doors.

Specify SELECT Hinges for long-lasting repairs that match your reputation.  
Replace worn-out hinges for good.  
No matter what state they're in.



SELECT Products Limited

Portage, MI 49024 800-423-1174 [www.select-hinges.com](http://www.select-hinges.com)

Hinge design tested for

10,000,000

cycles ... and counting.





Before.



After.

## Can you see the difference?

**With our latest electronic locks,  
it's what you can't see that really counts.**

Continuous improvement and smart design are a way of life at S&G. Improvements like our new deadlocking capability that provide an even higher level of security and durability in boltwork blocking applications.

And all of our electronic locks offer innovative features that make them more reliable, secure, and easy to use. Features like our advanced, motor-driven design that guard against bouncing and vibration attacks. Simple, yet clever innovations like putting our keypad connector outside the safe for convenient servicing. And the unique advantage of easily programming our locks using only the keypad.

Our electronic lock family is the broadest in the industry. And it's built tough and designed to fit most any commercial-grade application you may encounter. But most important, they're all backed by the S&G customer service and support that's always there when you need it.

So, if you haven't tried one of our electronic locks lately, contact your S&G Distributor and see the difference.

**See our latest  
electronic locks at  
ALOA - Booth 443.**



**SARGENT AND GREENLEAF**

A lock on security.

[www.sargentandgreenleaf.com](http://www.sargentandgreenleaf.com)

Circle 270 on Rapid Reply



**Author:** tsl ([asaplock@jvl.net](mailto:asaplock@jvl.net))

**Subject:** advertising what works?

I have started a new mobile locksmith business and it seems to be going rather slow. I am wondering if anyone can tell me what type of advertising works for them. I am strictly mobile and don't have a shop (too costly). So far this is what I have tried and the results.

I am in the Yellow Pages (this has resulted in only 2 calls in 2 weeks), I have done direct mail

ads to potential customers (3 jobs from about 300 mailed ads), and talked directly to the customers (10 or so jobs). Talking directly to the customers has worked the best, but it seems I've got the companies I am going to get. I tried expanding my advertising to other towns, with no results.

The clients I have worked for say they are very satisfied with my professionalism, appearance and work. If anyone has any ideas, please help, I need to pay the bills.

**Author:** Jack Conn ([lockshop6@aol.com](mailto:lockshop6@aol.com))

**Subject:** Memories...

Tsl, man, does your post bring back memories. 20 years ago or so I sat in that chair. There isn't a way you can make that phone ring, so relax. You seem to have covered all the bases pertaining to advertising, so give it some time.

If you continue to do quality work, you have a sure winner. Avoid at all costs the biggest mistake you can make. DO NOT lower your prices. It can get real tempting to undercut a competitor's price to get the work, but it will also be the biggest mistake of your life. Been there...done that.

Hang tough & good luck.

**Author:** Tom Lynch ([LynServe](mailto:LynServe))

**Subject:** You can do it!

Tsl, you have mentioned several things in your posting that are valid, however, you may want to redirect your focus.

To begin, the Yellow Pages are not profitable at this stage of your marketing push. It is a reactive form of advertisement that will not return your investment fast enough. A single bold line entry is sufficient. Utilizing your resources in a proactive manner will yield a higher response.

Secondly, focus solely on your services and your marketing, without concern of what the other companies are doing. I have reviewed other postings and see that many operate on an aggressive, arrogant and negative approach in dealing with both their services and marketing. Maintain an assertive, creative, problem solving program and you will make positive gains. There is a big difference between the two. If you focus on yourself, you will be able to achieve a set goal, if you worry about your competitor, your directing negative energy that will cause you to spin your wheels.

As a mobile operation, you are in a perfect situation to be profitable with little outlay and

# Open Forum

*Advertising and What Works*



you will be able to control your efforts with greater results. The first thing I suggest you do is to evaluate your competitor and discover what portion of the market is the weakest (automotive, residential, specialty hardware, safes, etc.) Then exploit that portion till you are the very best and market it hard. You will begin to obtain a foundation that will be overlooked by the competition, until they begin to recognize your growth and cash flow.

At that point (if they exemplify the negative qualities mentioned earlier) they will begin to try to reestablish what you have taken. This is good, because you have now caused them to focus their energies on you, rather than themselves. You will then have to be prepared to market another portion of the market that is important to your competitor. As you continue to karaoke step around the market in an assertive fashion, you will continue to grow at the expense of the competitors and gain valued market share.

When I began, I focused heavily on automotive and roadside service. I pushed the ceiling on this and it paid off, since everyone else was not skilled, or felt it was not worth it, like commercial or residential. It wasn't until I maintained steady growth and market share that the larger competitors took notice. Until then I was a typical negative comment.

When the commercial market stalled and I had cash flow from the auto service, then others wanted it and tried hard to reestablish their position. At that point I came around the back door and marketed creative programs for the commercial market. After obtaining some major accounts that the competitor now LOST, I was once again keeping the others worrying about my activities. Each time allowing me to surgically tap into neglected portions of this wonderful trade, without trying to compare myself to others.

While conducting all this, please maintain the attitude that your competitors are your contemporaries, and eventually you will be called upon as a resource for them and visa versa. Here are a few ideas to get started.

Contact NEBS printing and have door hangers made that state "Deadbolts Installed \$75", Lock It or Lose It!", include all your info and hit every home and condo community within a specific area that only has a knob-lock. Do this

on a Thursday. You may choose an Arrow deadbolt with a drive in bolt for speed of install. I consistently achieve a 10% response and schedule for Saturday installs.

Add a Lori cylinder and in many cases you will be able to upgrade the knob-lock. It is possible to achieve hundreds of dollars on a single day in a confined neighborhood. Offer a great deal on rekeys if paid in cash. Your offer must be appealing, and yes, it must be a discounted service or sale.

## DUGMORE & DUNCAN

SECURING YOUR WORLD



### FILLING YOUR NEEDS

Security has never been more of a concern than it is today. That's why it's especially important to feel confident about the company that provides you with all your security and related maintenance needs.

**DUGMORE & DUNCAN is that company.**



hes



Distributor of  
**ASSA ABLOY**  
Products

Call (888) 384-6673

FAX (888) 329-3846 • www.dugmore.com



The key is to get in the door and still profit handsomely by choosing the right products and upgrades.

Try to use a locksmith orientated keyway that will drive future business to you. Create a premium account status for those who have your keyway and tell them they are entitled to reduced service rates for as long as they maintain the system. This works great with commercial customers. Even if your competition begins to react by also buying into such a keyway, good, make them react and spend their resources.

Auto is easy, take your business card and stickers, advertising only "Auto Lockout Service" and visit every business in you area. Tell them you just unlocked a car outside their store for a customer and you wanted to make them aware of your services. Your sticker should say "Most cars opened \$35" also that cars are opened with no damage, 24/7. Try using artwork that has impact and is comical. Try to post

these stickers everywhere you can without getting into trouble.

Make deals with local carwashes, to help them for reduced rates, in exchange for services. Hit self-serve gas stations, hotels, beauty salons, barber shops etc. Notify all tow facilities and Police in writing that you will open cars for free, when a child is involved. The rate I quoted may or may not work in your area, the purpose is to generate calls in volume. Once you get these calls you must evaluate the type of vehicle you are being asked to service. Electric locks, window tint, auto relock, SIP Sys, prior attempts, all have a added charge on top of the base rate.

You will have to open "most" cars that are still out there without these features, but that will only last for period of time, until new models take over and by then you will have the ability to charge well. After a month, revisit these businesses with a different handout and continue this mercilessly. Try

to take every call that comes in and always have the auto keys in stock!

As you grow, you will have to create proposals and maintenance programs that will address "solutions" to your commercial customer problems. So often a locksmiths refusal to listen, leads to installations and sales of products that don't solve the problem the customer is having. Listen and react. Offer "preventative maintenance" programs where they prepay a specific amount that entitles them to a specific amount of service calls at no charge, with reduced labor if they install specific grade hardware.

Try to drive down their "time management and expenditures", while installing products that solve their problems. In the long run you will make more and "your" time management will be freed up to capture more accounts like this without concern of callbacks on low grade material. You are not lowering your prices, you are redirecting your sales approach in a proactive manner. If you only gain 10 customers of this type, at \$500 per year, that's \$5000.00 each year upfront to be invested in your growth or deposited to gain interest in you bank.

As time goes on you will work less due to the grade of hardware survival. I have operated like this for years and I've made more money on these type of accounts then any other, and no one can "draw them away".

Try to avoid office furniture cam lock jobs and antique hardware—it's not worth it. Refer all the bad jobs and difficult customers to your competition, let them spent time with these kinds of people. Sorry to be so long winded, I could cover more and I'm sure I've overlooked many other points, but I understand your position and I know that you can achieve and grow as a mobile operation if you try some of these approaches.

## Padlocks

- Solid Brass
- Made in USA
- Easily Repinned to Standard Keyways
- 13 Keyways Available



# ALMONT "Re-Key"

**Almont Lock Co.**  
P.O.Box 568  
Almont, MI  
48003-0568  
810.798.8950

### Re-Key Tool Features...

- Disassemble ALL parts and reassemble.
- No drilling...No Plugs to remove... No refinishing
- Remove Key Plug only..Leave upper pins and springs alone to "Re-Key."
- Remove Key Plug and replace ALL pins to Master-Key.
- Remove and Replace Shackles.



**Author: Wynn Kessler**  
(wynner5@ix.netcom.com)

Tom: Excellent dissertation pertaining to marketing. So good in fact, that it should be in my book, "Keys To Marketing Success" techniques that have produced proven results for myself and many others for many years. Published by Wynner Publications, 562-692-6063 (wynner5@ix.netcom.com)... sells for \$70.00, discounted to \$59.95 to Locksmiths on this site.

**Author: Garth Meredith**  
(merlock@connect.ab.ca)

**Subject: What works?**

I too have sat in your chair. In 1980 when I started, one of the things I found worked was (You'll excuse the horrible expression) COLD CALLS! It'll be the toughest thing you do, but if you've got no jobs, what have you got to lose? Go out to businesses in your town (I understand you've done this already) but with a little different approach. Don't try to convince the folks to switch to you right away, but explain to them that you're trying to get established, and if at any time the other locksmith is unavailable, ask them to try you.

Praise your opposition as professionals (if you know they are) but make it very clear to everyone that YOU are just as professional, as they will find out if they give you a try. Leave business cards everywhere you go and hand them out to everyone you meet, it's good inexpensive advertising. If the cost of professional printing is a problem, get Corell's Easy Business Card program for your computer, buy the blank cards from Staples, or Office Max, or wherever you shop, and print your own.

I wish you every success, but don't despair—if you do the best you can, the customers WILL come.

**Author: Phil Hight**  
(thekeysmith@bigfoot.com)

**Subject: Stay with it**

I agree with Garth Meredith, get out and make friends with your local businesses. Go in with a positive

attitude, look professional. Never push your services, and always stop back by and leave more cards. Go out to your local swap meet. Set up, cut keys, pass out more cards, be friendly. Go to every tow truck company and leave as many cards as possible. Give them a special rate to make keys to there Lien Sale Cars. This is the best place to practice new or old tricks.

That in itself has always helped me when business slows down. Remember, YOU ARE THE BEST in YOUR Field.

**Author: J McCord**  
(jmccord3@bellsouth.net)

**Subject: Super Way**

I am an older locksmith and have a little trick that will generate a lot of business for the least amount of expense. It is a business card holder that will disperse 25 cards at a time. This little holder can be pinned up on display boards. Magnetic holders can be affixed and placed on the back of metal cash registers. It works. 



**you're gonna need some sharp bits.**

Big job or small, save time and money with the drill bit sharpener that really works.

- Restores bits to factory sharp in less than 60 sec.
- Sharpens full range of bits, even split point
- Sharpens 118° and 135° -point, 3/32"-3/4" bits
- Tough 1.75-amp motor

*"With the Drill Doctor, our bits come out perfect every time. And it's LOTS faster than hand sharpening. It's easy to use. It sets itself up for the right angle. You just put the bit in, turn it a few times and it's done—with no guessing. AND we always get optimal performance out of our drill bits."*

— Mike & Carol Oar  
Elmer's Lock & Safe  
Medford, Oregon



**Drill Doctor**  
The Drill Bit Sharpener



1-888-MYDRILL (693-7455)  
Web: www.DrillDoctor.com

**750**

# BUSINESS BRIEFS

## **Camlock Systems Names Padjen General Manager**

Camlock Systems, Inc. has named Dale N. Padjen General Manager of their U.S. operations.



Padjen has over twenty years of experience in marketing security products to the vending, amusement, gaming and OEM markets. Camlock Systems is located in suburban Chicago and can be reached via email at [usasales@camlock.com](mailto:usasales@camlock.com).

## **Updated Templates for Adams Rite**

In keeping pace with emerging market trends and technology, Adams Rite has converted current product templates to Adobe PDF format and made them available for printing or download from their website at [www.adamsrite.com](http://www.adamsrite.com). Adams Rite has spent the last several months upgrading the website to help users easily navigate to templates, catalog pages, parts lists and installation instructions and plan to continue to develop its capabilities and functions

in the future. From the Adams Rite home page, the user simply clicks on the templates quick link tab located in the light green box in the lower left corner of the page. This will take the user directly to the categories of available templates, which include the 3000 Series Fire Rated Exit Devices, 8000 Series Life Safety Exit Devices, the RITE Door and Electric Strikes.

## **Medeco Web-Based Interactive Demo**

A free, online, interactive security demonstration helps security dealers explain high-security locks to customers. The Interactive Security Solutions demonstration at [www.medeco.com](http://www.medeco.com) uses three dimensional moving graphics and narration to show how keys, cylinders and pins interact in locks. The site's focus on locks for three distinct market segments—commercial, residential, and equipment—reflects Medeco's targeted audiences—business owners, homeowners, and original equipment manufacturers.

The site's commercial and residential specific sections offer a variety of features, including a brief security quiz to help owners assess their buildings' security risks, and a key program selector that customers can use to select the Medeco option that best suits their application.

## **DETEX Appoints Three New Jobs**

DETEX Corporation, Inc., a manufacturer of commercial life safety, security and security assurance products, has named Greg Drake as Director of Marketing and Sales. He is responsible for both Domestic and International Marketing and Sales.



DETEX has also announced that Paul Haeck has joined the company as the Engineering Manager. Paul is responsible for new product development and improvement/maintenance of existing product designs and overall management of the Engineering function.



DETEX has also named Tony Mudford as Vice President of Industry Affairs. Tony has been instrumental in the development of DETEX's international markets and has played an active high-level role in a variety of industry associations over his 27-year career at DETEX.

## **IR Acquisition of FX Technologies**

Ingersoll Rand has acquired the assets of FX Technologies. FX Tech. Provides one-source security systems integration solutions including consulting and database systems engineering for global corporations and other organizations with critical security requirements. FX Tech. will be integrated with IR's Electronic Technologies Corporation business unit, which operates in the USA as part of IR's Security and Safety Solutions.

With this acquisition IR has expanded its US sales and service branch network and enhanced their ability to serve established and prospective clients. **TNL**



# Isn't It About Time???

Quality. Durability.  
Dependability.  
Service After The Sale.  
Count On Framon.

We've been producing quality key machines since 1971. We know the business, and how to build a quality product. Take our #2 Code Machine for example—everything you need is supplied at time of purchase. We promise we won't keep digging in your pocket every year for more money. When new information comes out, visit our website & get it for free. Cutting a key by code? Shouldn't the key match up to the factory specifications instead of being "in the ballpark"? With one half-thousandth accuracy (.0005") in depth, the key you cut will be on the money. Send your customer away knowing he won't be back because the key doesn't work. If you're looking for a key machine, make us your first call...you won't be sorry later.

Visit Framon on the web at [www.framon.com](http://www.framon.com)—it's the on-line resource for Framon owners. Free updated depth & space information, key cutting tips, and our entire line of key machines, software, and locksmith tools. Stop by today!

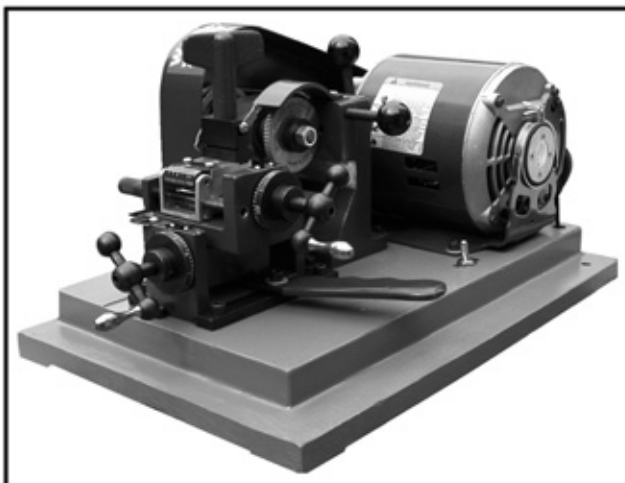

All Framon products are sold through our distributors.

## Still Not Sure? How About A Few Words From Our Customers...

"I love your machine, working the rough roads in Alaska I never worry about the keys I generate. The machine is a blessing. It's so easy sometimes I'll decode a key and cut it by code on the #2 just so my customer gets a perfect key. Takes only seconds to do. Thanks for building such a great machine."

Chuck Jones, Wasilla, Alaska

"I have to say that Framon really does have the best customer service out there. You add that to a machine that lasts a lifetime and does all you need in the code dept and you just can't go wrong buying a Framon. It's a pleasure to deal with someone who treats you like they appreciate your business."

George Henderson

"I recently purchased a used Framon #2. It was not functioning properly when I got it, so I sent it in to Framon for repair. I e-mailed Framon to ask about servicing, and they responded in a quick and helpful manner each time.

The day it arrived at Framon (I tracked it), they called me from the repairs department. He was courteous and pointed out a few things that I was unaware of. He told me that he would ship it out the very same day. He even took the time to answer my limitless questions about it.

I am utterly impressed with this level of service. Their website mentioned a two-day turnaround time for repairs, but I didn't fully believe it. It is a great experience to actually find a company that lives up to their word."

Merlin Young

## Make Us Your First Call For Key Machines!



Demonstration video available. Call or e-mail for details.

**Framon Manufacturing  
Company, Inc.**

909 Washington Ave.

Alpena, MI 49707

Phone: (989) 354-5623

Fax: (989) 354-4238

E-mail: [sales@framon.com](mailto:sales@framon.com)

Website: [www.framon.com](http://www.framon.com)

# KEY CODES

## Infiniti X1-X7000

**Manufacturer:** \_\_\_\_\_ Infiniti  
**Code Series:** \_\_\_\_\_ X1-X7000

**Key Blanks:**

**ILCO:** \_\_\_\_\_ X210, DA31,  
X123, DA25, X124, DA28, NSN11T2

**Jet:** \_\_\_\_\_ DA25,  
DA25-NP, DA31-NP

**Silca:** \_\_\_\_\_ NSN11, DAT13,  
DAT14, NSN11T2

**Number of Cuts:** \_\_\_\_\_ 8

**M.A.C.S.:** \_\_\_\_\_ 2

**Cut to Cut Spacings:** \_\_\_\_\_ .085

**Spacings:**

- 1 - .118
- 2 - .203
- 3 - .288
- 4 - .373
- 5 - .458
- 6 - .543
- 7 - .628
- 8 - .713

**HPC 1200Blitz**  
XF67

**ITL Mfg.**  
138

**Pak-A-Punch**  
PAK-N1

**Depths:**

- 1 = .276
- 2 = .256
- 3 = .236
- 4 = .217

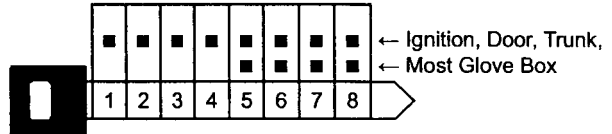
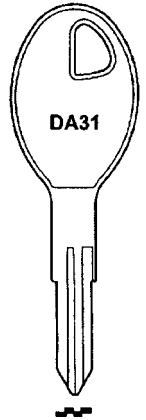
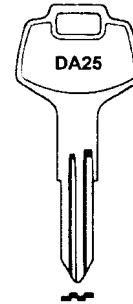

X0001	13244213	X0039	11233433	X0077	33211321	X0115	13442112	X0153	32422311	X0191	23213344
X0002	31334231	X0040	32231122	X0078	43231122	X0116	22344232	X0154	21134243	X0192	23233234
X0003	43242232	X0041	32122112	X0079	24231123	X0117	13344223	X0155	43423231	X0193	33231213
X0004	23424333	X0042	32211243	X0080	21112344	X0118	12343313	X0156	42432344	X0194	33321231
X0005	23423244	X0043	32423424	X0081	43112133	X0119	13132242	X0157	44332424	X0195	22231132
X0006	32433342	X0044	32344321	X0082	31221243	X0120	31132231	X0158	13331113	X0196	22342124
X0007	21243111	X0045	31123442	X0083	32433234	X0121	33232111	X0159	42433433	X0197	33111221
X0008	42223432	X0046	21234231	X0084	31331344	X0122	44323224	X0160	22132121	X0198	13322434
X0009	23343212	X0047	43212211	X0085	22343442	X0123	31132121	X0161	11343222	X0199	22334213
X0010	33422444	X0048	33242112	X0086	13343123	X0124	13443221	X0162	13344421	X0200	34421121
X0011	31133221	X0049	22434434	X0087	31322342	X0125	34344242	X0163	34233342	X0201	31324322
X0012	33242233	X0050	32432442	X0088	44233431	X0126	42223344	X0164	34224342	X0202	42332231
X0013	43312212	X0051	23344343	X0089	21112223	X0127	34424234	X0165	33243122	X0203	44213334
X0014	21244243	X0052	11223223	X0090	24243344	X0128	21224342	X0166	22243432	X0204	32232312
X0015	33224233	X0053	13442231	X0091	24334244	X0129	23221123	X0167	33433442	X0205	32121133
X0016	33131221	X0054	31322221	X0092	31212243	X0130	22442132	X0168	22421113	X0206	34234433
X0017	11132424	X0055	23433212	X0093	11133124	X0131	31342234	X0169	13123244	X0207	32112133
X0018	13334224	X0056	32242311	X0094	11133213	X0132	12444322	X0170	11231212	X0208	13433222
X0019	32432431	X0057	13224431	X0095	31124234	X0133	43312133	X0171	43212242	X0209	23444232
X0020	11333342	X0058	11234243	X0096	43422111	X0134	32433423	X0172	13443432	X0210	33444231
X0021	22244233	X0059	11332424	X0097	23311334	X0135	24432212	X0173	31332231	X0211	31132134
X0022	31131344	X0060	43324433	X0098	42213134	X0136	11312334	X0174	24331223	X0212	12323122
X0023	21334223	X0061	43432112	X0099	32212112	X0137	33133421	X0175	32211232	X0213	21243334
X0024	43431124	X0062	23224432	X0100	42233321	X0138	34244322	X0176	42342122	X0214	23244432
X0025	42443421	X0063	42112431	X0101	44422213	X0139	33123213	X0177	34431122	X0215	11231134
X0026	12433212	X0064	34432424	X0102	24221324	X0140	12112243	X0178	13244233	X0216	31222244
X0027	43331244	X0065	23442232	X0103	32131132	X0141	34431223	X0179	33122432	X0217	42332334
X0028	43222342	X0066	24324313	X0104	43223323	X0142	32334322	X0180	44211332	X0218	24221313
X0029	33443243	X0067	12422432	X0105	42333342	X0143	24422321	X0181	22311322	X0219	24311124
X0030	13323224	X0068	23213432	X0106	12221132	X0144	23433432	X0182	43443233	X0220	43243312
X0031	31134442	X0069	33222132	X0107	43123423	X0145	33344421	X0183	21213234	X0221	42423423
X0032	13324313	X0070	34423442	X0108	43112432	X0146	34432334	X0184	24423234	X0222	42432234
X0033	24223313	X0071	21221132	X0109	22331223	X0147	42122432	X0185	43223422	X0223	13221324
X0034	23233421	X0072	34233243	X0110	43332113	X0148	31342423	X0186	23443442	X0224	24213233
X0035	12133311	X0073	34243334	X0111	24231321	X0149	34222443	X0187	33213213	X0225	33423434
X0036	33432234	X0074	12124431	X0112	12433432	X0150	13312444	X0188	43133134	X0226	13212344
X0037	21332113	X0075	23431232	X0113	24422121	X0151	34422243	X0189	33422312	X0227	42234322
X0038	13423124	X0076	12232233	X0114	12224333	X0152	21112423	X0190	33424332	X0228	22434311



# Dave McOmie on Lift-Out Round Doors from The National Locksmith®



**NEW!**

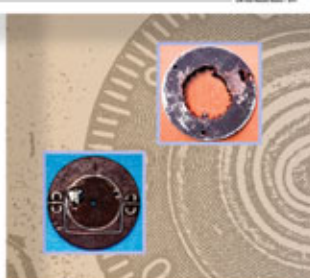
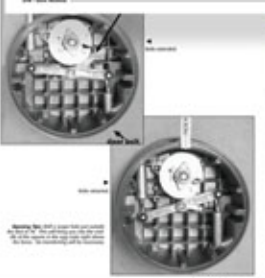
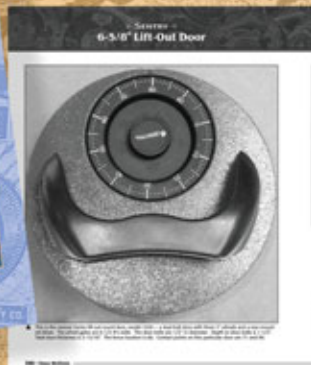

Dave McOmie on **Lift-Out Round Doors**



At long last, we are pleased to announce **Dave McOmie on Lift-Out Round Doors!** This newly published book contains 317 pages (not counting the lengthy introduction), 664 photographs, and more than 40,000 words of text. It covers just about every lift-out round door you will ever see, and a whole lot more (54 different manufacturers, to be precise). Included in the text are drill points, relocker drill points, depth to door bolts, door thickness, door diameter, and many, many tips and tricks.

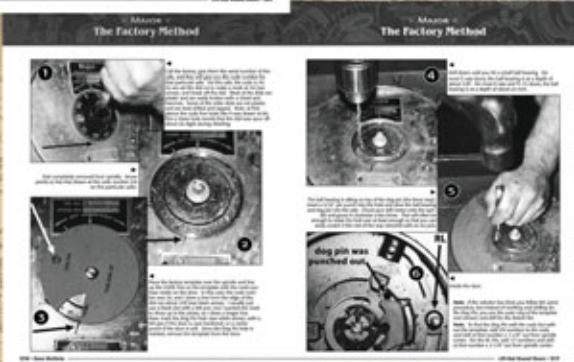

**YES!** Send me *Dave McOmie On Lift-Out Round Doors* for **\$125**. Plus \$8 for shipping and handling.

Orders must be paid in U.S. funds. \$20 foreign shipping rate applies.

Select payment Method:

- Check  VISA  MasterCard  Discover  
 American Express  Money Order

Order Total \_\_\_\_\_

Card Number \_\_\_\_\_

Exp. Date \_\_\_\_\_

Signature (required) \_\_\_\_\_

Name \_\_\_\_\_

Shop Name \_\_\_\_\_

Address (no P.O. boxes) \_\_\_\_\_

City \_\_\_\_\_

State \_\_\_\_\_ Zip \_\_\_\_\_

Phone \_\_\_\_\_

Fax \_\_\_\_\_

E-Mail (optional) \_\_\_\_\_

Copy or clip this coupon and send with payment to:

The National Locksmith • P.O. Box 77-97592 • Chicago, Illinois 60678-7592

OR fax credit card orders to (630) 837-1210

OID 04/04

# Infiniti X1-X7000

X0229	42324322	X0291	21334331	X0353	23113222	X0415	21223123	X0477	21233223	X0539	43113323
X0230	32112432	X0292	12243422	X0354	12222133	X0416	42112444	X0478	44323424	X0540	21133224
X0231	43122323	X0293	33243234	X0355	42443113	X0417	44322331	X0479	43421213	X0541	42134422
X0232	22113243	X0294	12443431	X0356	11313422	X0418	11244323	X0480	42112213	X0542	21233322
X0233	11334422	X0295	13223434	X0357	32113231	X0419	24312123	X0481	13243443	X0543	31344322
X0234	43112421	X0296	24443221	X0358	33342443	X0420	31223421	X0482	32122424	X0544	44334213
X0235	23431212	X0297	11313313	X0359	11332224	X0421	42331324	X0483	32133134	X0545	23223334
X0236	22123444	X0298	22213213	X0360	43222344	X0422	43342343	X0484	23343344	X0546	44312231
X0237	31234344	X0299	32113321	X0361	32423112	X0423	31342223	X0485	34223224	X0547	13343244
X0238	42124344	X0300	12434431	X0362	12442212	X0424	43322444	X0486	32133312	X0548	23133112
X0239	13223111	X0301	32424313	X0363	33112123	X0425	42313324	X0487	34421332	X0549	34322321
X0240	43343223	X0302	33321312	X0364	13342443	X0426	13113313	X0488	12424324	X0550	33242442
X0241	22113124	X0303	44342223	X0365	23224421	X0427	13313113	X0489	23443242	X0551	12134331
X0242	21113244	X0304	32433434	X0366	33121123	X0428	42423313	X0490	23221244	X0552	43432442
X0243	21133132	X0305	42312433	X0367	31233132	X0429	13311344	X0491	24312323	X0553	44342124
X0244	33243342	X0306	21332324	X0368	13232212	X0430	42421342	X0492	22432421	X0554	12433113
X0245	43132432	X0307	43122132	X0369	43223424	X0431	42422431	X0493	43121344	X0555	13232111
X0246	44312112	X0308	31322122	X0370	12334243	X0432	21211232	X0494	31232331	X0556	13443322
X0247	13442121	X0309	31121132	X0371	34211223	X0433	11344432	X0495	13321334	X0557	42421331
X0248	31242111	X0310	31233222	X0372	43323324	X0434	23133424	X0496	32212134	X0558	22121332
X0249	34232231	X0311	43331121	X0373	33311322	X0435	33112444	X0497	34232132	X0559	11213334
X0250	34433232	X0312	12342433	X0374	43111332	X0436	34242313	X0498	12342442	X0560	31242312
X0251	43322134	X0313	42133133	X0375	13123332	X0437	11223133	X0499	34331242	X0561	24213134
X0252	44231132	X0314	23433443	X0376	42233224	X0438	33131234	X0500	44223131	X0562	33123321
X0253	44343224	X0315	12343212	X0377	34331244	X0439	44332224	X0501	12244223	X0563	44322311
X0254	32243224	X0316	23434222	X0378	43423433	X0440	21132234	X0502	23311123	X0564	44422323
X0255	43122334	X0317	22213343	X0379	24343224	X0441	31233231	X0503	12222113	X0565	22433233
X0256	34211234	X0318	31123244	X0380	33322124	X0442	23323124	X0504	22442343	X0566	31243232
X0257	32342343	X0319	43311213	X0381	33421234	X0443	33224321	X0505	24211231	X0567	32431232
X0258	13243332	X0320	21211243	X0382	43422342	X0444	43323423	X0506	24223432	X0568	34212213
X0259	43131224	X0321	12444324	X0383	34322244	X0445	32122431	X0507	24332332	X0569	22443324
X0260	12231342	X0322	11311333	X0384	42312233	X0446	22424321	X0508	44244231	X0570	21122321
X0261	12323443	X0323	13333124	X0385	11333223	X0447	21113332	X0509	33234432	X0571	13344232
X0262	42322333	X0324	34244324	X0386	31324324	X0448	43323124	X0510	42422323	X0572	34223334
X0263	43242133	X0325	32312342	X0387	13323424	X0449	43132212	X0511	21322323	X0573	22324344
X0264	32324343	X0326	22211233	X0388	13124243	X0450	22243421	X0512	43234424	X0574	34221213
X0265	42242312	X0327	32334324	X0389	12443332	X0451	42211211	X0513	24442134	X0575	31232234
X0266	43433421	X0328	13232443	X0390	23112212	X0452	34243242	X0514	43343324	X0576	43223211
X0267	13133211	X0329	33111322	X0391	23213124	X0453	44332132	X0515	12224432	X0577	22321134
X0268	33422431	X0330	42234443	X0392	11224334	X0454	32234422	X0516	24211233	X0578	24224321
X0269	31223122	X0331	43211212	X0393	34332111	X0455	23434231	X0517	34424333	X0579	34324323
X0270	43323243	X0332	12332111	X0394	23243343	X0456	32311233	X0518	23134423	X0580	33132444
X0271	42323123	X0333	42344432	X0395	31224321	X0457	42333223	X0519	31234322	X0581	33422224
X0272	22113133	X0334	21333111	X0396	34211311	X0458	42422424	X0520	43242111	X0582	34423321
X0273	13221122	X0335	23323342	X0397	34243332	X0459	34421134	X0521	24343211	X0583	44422231
X0274	13112334	X0336	23432242	X0398	13442431	X0460	43431131	X0522	23422333	X0584	24233321
X0275	44323422	X0337	13221313	X0399	32123331	X0461	13434421	X0523	44322234	X0585	23433113
X0276	24432322	X0338	42212133	X0400	42423331	X0462	23442124	X0524	44213332	X0586	44213242
X0277	24321244	X0339	13213233	X0401	32442234	X0463	22332211	X0525	12112324	X0587	32443334
X0278	23244322	X0340	24434432	X0402	11331232	X0464	13113212	X0526	42421131	X0588	12223132
X0279	12231312	X0341	43323342	X0403	24233134	X0465	23311224	X0527	34232444	X0589	31342243
X0280	43131123	X0342	43312322	X0404	13424431	X0466	13443421	X0528	12324323	X0590	21324244
X0281	24334424	X0343	32112421	X0405	31322344	X0467	43442113	X0529	23123423	X0591	23422131
X0282	12311312	X0344	11224422	X0406	23342323	X0468	42133423	X0530	23423123	X0592	13331232
X0283	11133331	X0345	12423433	X0407	24434322	X0469	43312423	X0531	43432431	X0593	11122331
X0284	12424322	X0346	31322322	X0408	22334442	X0470	22323343	X0532	42422334	X0594	34342323
X0285	24311333	X0347	32223424	X0409	42324324	X0471	34434213	X0533	22432443	X0595	21333224
X0286	23124422	X0348	21342323	X0410	42342324	X0472	22131221	X0534	21322334	X0596	32224313
X0287	12433443	X0349	11243324	X0411	44234221	X0473	31243423	X0535	33421122	X0597	44422334
X0288	33213211	X0350	42334334	X0412	12133422	X0474	23244324	X0536	44321323	X0598	31322223
X0289	42132334	X0351	42443234	X0413	32322334	X0475	13313122	X0537	42233422	X0599	44213431
X0290	31342211	X0352	23213234	X0414	42312244	X0476	24423223	X0538	32312234	X0600	31113313



# Infiniti X1-X7000

X0601	32131321	X0663	32132131	X0725	24432331
X0602	43112221	X0664	31212443	X0726	42231134
X0603	31331113	X0665	13132431	X0727	21133433
X0604	33324344	X0666	13423131	X0728	21324233
X0605	24434324	X0667	31244224	X0729	42111232
X0606	12223321	X0668	22311313	X0730	23122132
X0607	12332221	X0669	13211244	X0731	42222431
X0608	44432331	X0670	34331121	X0732	11132224
X0609	32124433	X0671	42442334	X0733	24443322
X0610	13333111	X0672	22424334	X0734	42233424
X0611	24342212	X0673	13122333	X0735	24421331
X0612	33112334	X0674	22131344	X0736	42433224
X0613	12132243	X0675	32132133	X0737	44234342
X0614	42111243	X0676	21244421	X0738	32123324
X0615	44222312	X0677	44221243	X0739	44223221
X0616	32134221	X0678	31112312	X0740	43213423
X0617	31224334	X0679	32123133	X0741	44221324
X0618	24312442	X0680	43322431	X0742	23321124
X0619	24421342	X0681	43121122	X0743	13433424
X0620	33123231	X0682	44331122	X0744	12311132
X0621	33211323	X0683	42234331	X0745	13223122
X0622	33324234	X0684	32234312	X0746	23422113
X0623	13231213	X0685	11311344	X0747	44421124
X0624	42333243	X0686	23122334	X0748	23224324
X0625	11343343	X0687	31342124	X0749	33443324
X0626	11322124	X0688	42431332	X0750	34443332
X0627	42331223	X0689	42111324	X0751	42311333
X0628	44213442	X0690	24342124	X0752	12332331
X0629	22333113	X0691	44232443	X0753	32222313
X0630	31113212	X0692	42311124	X0754	34224311
X0631	13312332	X0693	11231321	X0755	33243243
X0632	31234443	X0694	42421113	X0756	12432231
X0633	21233243	X0695	44233231	X0757	33234243
X0634	32434213	X0696	43421121	X0758	42313212
X0635	12123432	X0697	13132442	X0759	21331224
X0636	24334332	X0698	23312113	X0760	12443213
X0637	44223113	X0699	13213134	X0761	34224434
X0638	24234432	X0700	34311312	X0762	23422234
X0639	33434221	X0701	23322424	X0763	23422423
X0640	12423132	X0702	42223331	X0764	33321132
X0641	23324244	X0703	33312224	X0765	11223434
X0642	24311344	X0704	32113334	X0766	23211212
X0643	43442331	X0705	43322424	X0767	44421322
X0644	44421333	X0706	32224423	X0768	11242213
X0645	33431132	X0707	32442223	X0769	32111321
X0646	32444322	X0708	31222433	X0770	12343342
X0647	23444313	X0709	22433242	X0771	22343321
X0648	42133434	X0710	24421131	X0772	44211244
X0649	43324244	X0711	42211123	X0773	44243223
X0650	44332312	X0712	31122421	X0774	33442123
X0651	13334213	X0713	34213232	X0775	12133444
X0652	23122323	X0714	21344323	X0776	34243244
X0653	13432122	X0715	42311133	X0777	21324424
X0654	44312134	X0716	22333212	X0778	34422432
X0655	34334342	X0717	22133234	X0779	11224244
X0656	32213232	X0718	21131134	X0780	42243131
X0657	33112224	X0719	32112221	X0781	23324233
X0658	11231123	X0720	13343121	X0782	21312223
X0659	33124443	X0721	12334443	X0783	34222331
X0660	42112112	X0722	23312122	X0784	31134224
X0661	42134242	X0723	43243213	X0785	22231231
X0662	34332221	X0724	23332423	X0786	11212342

## HOMELAND SECURITY PROMOTION

Buy 3 Gardall Safes at a  
great price and get the  
rest for FREE...

- Vinyl 6' x 2' banner
- Carpeted safe display stand
- Wall poster
- FREE promotional literature



Homerack-0-0

Contact your Gardall Distributor  
for price and availability.

**Gardall**<sup>®</sup>

Gardall Safe Corporation

"The Locksmith's Safe Company"

# Infiniti

## X1-X7000

X0787	31324423	X0849	33132123	X0911	21243244	X0973	32132344	X1035	33443131	X1097	22322344
X0788	43324233	X0850	11243212	X0912	13211222	X0974	42132213	X1036	34442342	X1098	33122234
X0789	42121121	X0851	33423421	X0913	21344224	X0975	43421231	X1037	43244243	X1099	11333113
X0790	32213212	X0852	22443131	X0914	21312324	X0976	32223442	X1038	34433221	X1100	43132434
X0791	12234433	X0853	42122342	X0915	43223343	X0977	21113231	X1039	43332212	X1101	43423134
X0792	24224334	X0854	43333442	X0916	32443332	X0978	13243423	X1040	24233422	X1102	33312244
X0793	22244231	X0855	34432242	X0917	33431224	X0979	43224221	X1041	42212333	X1103	12323324
X0794	21231243	X0856	42342443	X0918	32311334	X0980	44213321	X1042	13324344	X1104	22433321
X0795	21121133	X0857	13113122	X0919	13431224	X0981	21223312	X1043	42332224	X1105	44312123
X0796	33432232	X0858	12313211	X0920	12124433	X0982	22342113	X1044	11221243	X1106	34321124
X0797	13432232	X0859	11242433	X0921	34234233	X0983	21332212	X1045	33422213	X1107	12231223
X0798	23312331	X0860	13323244	X0922	34243233	X0984	42432232	X1046	42223324	X1108	21311312
X0799	23321221	X0861	21233133	X0923	13323321	X0985	23443222	X1047	34312342	X1109	43332124
X0800	44221122	X0862	12233124	X0924	34324211	X0986	43244333	X1048	22444233	X1110	33423342
X0801	32124312	X0863	43122211	X0925	12422434	X0987	33124322	X1049	23131233	X1111	23112122
X0802	13233222	X0864	44231231	X0926	13223421	X0988	11344331	X1050	13443133	X1112	11221324
X0803	43232233	X0865	33442211	X0927	13322111	X0989	31324311	X1051	34422221	X1113	32342244
X0804	43123221	X0866	12233423	X0928	11224233	X0990	34234442	X1052	12233434	X1114	13442312
X0805	43433124	X0867	13233132	X0929	32433131	X0991	22324443	X1053	24423313	X1115	23121122
X0806	22234432	X0868	24323121	X0930	33423221	X0992	12313444	X1054	12242313	X1116	31244343
X0807	44313221	X0869	13242132	X0931	32123111	X0993	31234331	X1055	21332124	X1117	21234424
X0808	33244334	X0870	42344331	X0932	32112342	X0994	12123133	X1056	34232211	X1118	24312211
X0809	42443243	X0871	42242112	X0933	32344242	X0995	22112424	X1057	43343111	X1119	42121334
X0810	22231233	X0872	32222311	X0934	34222311	X0996	42112233	X1058	22423331	X1120	13422332
X0811	33322421	X0873	24312343	X0935	42433442	X0997	42122434	X1059	31311324	X1121	42311344
X0812	34322112	X0874	44221313	X0936	44232344	X0998	42243313	X1060	11334312	X1122	32244333
X0813	13132132	X0875	24421113	X0937	11243432	X0999	43113431	X1061	23444234	X1123	13113322
X0814	43112342	X0876	13334442	X0938	44323244	X1000	44234421	X1062	23324213	X1124	44333111
X0815	44242334	X0877	31334422	X0939	13244231	X1001	21321234	X1063	42243221	X1125	42124423
X0816	13322124	X0878	33122342	X0940	43312243	X1002	31223434	X1064	22312321	X1126	31234423
X0817	13423113	X0879	24434331	X0941	43232242	X1003	21243343	X1065	12123324	X1127	12423424
X0818	42234423	X0880	34234211	X0942	42123334	X1004	23113444	X1066	31331232	X1128	42343343
X0819	21331321	X0881	44231233	X0943	42334442	X1005	43223442	X1067	34331312	X1129	33243124
X0820	12224421	X0882	12423334	X0944	42231211	X1006	42332211	X1068	21243233	X1130	22124333
X0821	12442221	X0883	31312424	X0945	13233231	X1007	31243324	X1069	34434321	X1131	12321344
X0822	42333423	X0884	21343124	X0946	43133132	X1008	21213423	X1070	12442234	X1132	34213324
X0823	33113432	X0885	44211242	X0947	44342221	X1009	32124343	X1071	22234243	X1133	34443213
X0824	12322424	X0886	22444213	X0948	13234432	X1010	32233131	X1072	11244312	X1134	24333113
X0825	42324423	X0887	43433223	X0949	43423211	X1011	43113312	X1073	43212444	X1135	23132113
X0826	32443431	X0888	32223343	X0950	22121132	X1012	43243321	X1074	42121134	X1136	31242233
X0827	22342423	X0889	23423444	X0951	44311333	X1013	12431324	X1075	24324344	X1137	43112344
X0828	11311324	X0890	12312322	X0952	32124431	X1014	11213442	X1076	42312431	X1138	23342123
X0829	13442332	X0891	31342232	X0953	22112132	X1015	21123423	X1077	12424311	X1139	33122322
X0830	34442133	X0892	12244342	X0954	21344244	X1016	42324311	X1078	42112134	X1140	12313421
X0831	23324424	X0893	42113344	X0955	24244334	X1017	31224244	X1079	34221231	X1141	31224233
X0832	43423213	X0894	22131234	X0956	42442123	X1018	31332224	X1080	13243232	X1142	43112223
X0833	12231243	X0895	22442233	X0957	43312311	X1019	22432113	X1081	23131244	X1143	12333442
X0834	11233442	X0896	31332111	X0958	11244242	X1020	22431213	X1082	24321224	X1144	12434433
X0835	22433213	X0897	32422421	X0959	22312213	X1021	33324443	X1083	24342221	X1145	13422343
X0836	11343242	X0898	43113224	X0960	22344234	X1022	12312423	X1084	34224313	X1146	21331211
X0837	33123123	X0899	11342421	X0961	24332321	X1023	11334431	X1085	31244323	X1147	13432432
X0838	43324424	X0900	21122433	X0962	32243134	X1024	32221332	X1086	12422331	X1148	11122243
X0839	13434434	X0901	12344222	X0963	32442313	X1025	31122344	X1087	22134334	X1149	12431321
X0840	24442323	X0902	32213434	X0964	31321334	X1026	32321122	X1088	42442132	X1150	21131224
X0841	22322443	X0903	44311133	X0965	12113222	X1027	43113442	X1089	11321343	X1151	12332223
X0842	22344311	X0904	44231244	X0966	11213242	X1028	11342333	X1090	22421342	X1152	33244224
X0843	42313311	X0905	44213244	X0967	31122322	X1029	23131231	X1091	12223433	X1153	44223432
X0844	42242233	X0906	42233444	X0968	21122231	X1030	44211222	X1092	34442111	X1154	11343244
X0845	22231244	X0907	21113321	X0969	31132224	X1031	22123321	X1093	42233134	X1155	21224423
X0846	13421243	X0908	42323121	X0970	12244232	X1032	42112244	X1094	11234434	X1156	34421213
X0847	43124332	X0909	23424423	X0971	12213232	X1033	12123342	X1095	42224442	X1157	23223134
X0848	32444324	X0910	31311344	X0972	34213434	X1034	31233431	X1096	32442443	X1158	43422124



# Infiniti X1-X7000

X1159	43132122	X1221	12112333	X1283	43133224
X1160	43121243	X1222	12133431	X1284	12212433
X1161	34311132	X1223	23111233	X1285	33111243
X1162	13313322	X1224	22421331	X1286	44213123
X1163	43331132	X1225	31331212	X1287	44331322
X1164	34321221	X1226	33134424	X1288	21233212
X1165	23132234	X1227	12423332	X1289	13424433
X1166	44243133	X1228	12224324	X1290	11324432
X1167	12342312	X1229	34311211	X1291	43122233
X1168	13312112	X1230	33133111	X1292	32112344
X1169	11332112	X1231	23134443	X1293	34212334
X1170	11332244	X1232	31212211	X1294	34312234
X1171	42333113	X1233	42221324	X1295	22443344
X1172	33124324	X1234	42312224	X1296	43113233
X1173	11333212	X1235	33442242	X1297	42311324
X1174	21332432	X1236	34332223	X1298	44332112
X1175	23113213	X1237	22112332	X1299	22433132
X1176	32131222	X1238	42231321	X1300	44223344
X1177	22442213	X1239	12334423	X1301	44332244
X1178	32332421	X1240	43233421	X1302	11312331
X1179	11342212	X1241	21334311	X1303	32233221
X1180	23443433	X1242	24324331	X1304	31232432
X1181	21131123	X1243	21223233	X1305	23223244
X1182	32244243	X1244	11244332	X1306	23342224
X1183	12323423	X1245	31222444	X1307	23423343
X1184	34442333	X1246	32434321	X1308	32112223
X1185	11211323	X1247	23313213	X1309	42123332
X1186	12133242	X1248	22431121	X1310	32221123
X1187	23233113	X1249	24443133	X1311	22342243
X1188	33212212	X1250	21244311	X1312	22333243
X1189	11343112	X1251	11312213	X1313	11213244
X1190	11322333	X1252	43112124	X1314	23134243
X1191	23331134	X1253	42312132	X1315	43312124
X1192	32233122	X1254	23323113	X1316	23113211
X1193	22422334	X1255	43121124	X1317	33344223
X1194	32423321	X1256	44331124	X1318	24243131
X1195	24223331	X1257	44421234	X1319	31113322
X1196	33221322	X1258	13123334	X1320	32443213
X1197	42231123	X1259	24221342	X1321	42134231
X1198	23332243	X1260	24312242	X1322	22123123
X1199	31112332	X1261	32332443	X1323	32311224
X1200	34223134	X1262	43323113	X1324	43342244
X1201	13324331	X1263	44433224	X1325	34232112
X1202	13342331	X1264	43332432	X1326	34223244
X1203	23342332	X1265	24233424	X1327	12443422
X1204	24224244	X1266	23123221	X1328	32432233
X1205	33244244	X1267	32342231	X1329	23322123
X1206	23324332	X1268	11243421	X1330	12134423
X1207	21124244	X1269	13211332	X1331	11321313
X1208	32243231	X1270	32133132	X1332	13344311
X1209	13321132	X1271	42333212	X1333	12124343
X1210	23344323	X1272	43122121	X1334	21113334
X1211	12213434	X1273	32344213	X1335	44321134
X1212	11342344	X1274	13322421	X1336	44311344
X1213	32433111	X1275	24333342	X1337	11321123
X1214	31321312	X1276	43423332	X1338	23322442
X1215	42242433	X1277	44243232	X1339	32131231
X1216	33113342	X1278	12443334	X1340	12321131
X1217	42344324	X1279	23442113	X1341	43331242
X1218	33122344	X1280	22424424	X1342	42322421
X1219	44322432	X1281	23113424	X1343	13321213
X1220	43112423	X1282	32222443	X1344	23112243

hes

Raising the Standards

## 9500 series



**The Completely Surface  
Mounted, Fire Rated Solution**

[www.hesinnovations.com](http://www.hesinnovations.com)

An ASSA ABLOY Group company

**ASSA ABLOY**

# Infiniti X1-X7000

X1345	24342234	X1407	42242442	X1469	12132432	X1531	13113232	X1560	44312343	X1589	31344221
X1346	11234221	X1408	22312433	X1470	13223322	X1532	22313324	X1561	13133113	X1590	42324342
X1347	42311122	X1409	42442242	X1471	12434233	X1533	44423131	X1562	24344342	X1591	13312134
X1348	34212132	X1410	23323311	X1472	44224334	X1534	44432421	X1563	32433421	X1592	13113423
X1349	42244231	X1411	31221122	X1473	34342224	X1535	32123432	X1564	31324342	X1593	32321124
X1350	32111323	X1412	44423432	X1474	23333121	X1536	32243323	X1565	21244313	X1594	22233334
X1351	42432432	X1413	12223112	X1475	22113443	X1537	32334223	X1566	33422334	X1595	42243122
X1352	32311123	X1414	44421122	X1476	31221313	X1538	33422323	X1567	43211311	X1596	23313222
X1353	32112423	X1415	43321122	X1477	31312213	X1539	43313123	X1568	21334432	X1597	21124442
X1354	13423443	X1416	21223431	X1478	32424331	X1540	42112123	X1569	44212212	X1598	31243432
X1355	23424221	X1417	12312313	X1479	13424334	X1541	43123421	X1570	21121223	X1599	32134223
X1356	32421123	X1418	22423324	X1480	23221134	X1542	13433231	X1571	43442421	X1600	34422223
X1357	34342123	X1419	31123334	X1481	32123122	X1543	21343421	X1572	34234222	X1601	43212343
X1358	24211343	X1420	32443211	X1482	33113322	X1544	13233431	X1573	32332234	X1602	13332444
X1359	33121244	X1421	22332424	X1483	43211342	X1545	23433232	X1574	32133224	X1603	32243123
X1360	11321321	X1422	22113421	X1484	21224234	X1546	33231224	X1575	22133423	X1604	12234442
X1361	31221324	X1423	12122442	X1485	44223243	X1547	43123243	X1576	24243221	X1605	13321311
X1362	24224233	X1424	12313242	X1486	22432423	X1548	12442243	X1577	32134342	X1606	21312333
X1363	42221313	X1425	24233444	X1487	43213221	X1549	34331132	X1578	22312424	X1607	32224344
X1364	43222111	X1426	21134221	X1488	33422424	X1550	23233432	X1579	32432134	X1608	12113444
X1365	44324432	X1427	22133133	X1489	24322131	X1551	11122133	X1580	32332122	X1609	33244343
X1366	44342113	X1428	13422244	X1490	33224213	X1552	12342211	X1581	23324231	X1610	42323321
X1367	13342322	X1429	21231342	X1491	33223423	X1553	12234233	X1582	42134321	X1611	24224213
X1368	42343242	X1430	42433112	X1492	24342113	X1554	43311312	X1583	33242433	X1612	13423234
X1369	21124233	X1431	23211331	X1493	32432121	X1555	24223324	X1584	42344212	X1613	21132113
X1370	31122122	X1432	24323123	X1494	13312231	X1556	43211223	X1585	33424233	X1614	24333223
X1371	31322443	X1433	33424422	X1495	22333423	X1557	24443311	X1586	34423323	X1615	24423344
X1372	42134431	X1434	12434211	X1496	21322433	X1558	33422231	X1587	24313324	X1616	43344222
X1373	32442221	X1435	43211234	X1497	13221331	X1559	12431243	X1588	42131133	X1617	12432224
X1374	23442324	X1436	44224422	X1498	13112321						
X1375	24211224	X1437	42312312	X1499	12321113						
X1376	21344312	X1438	13442422	X1500	24422332						
X1377	13443311	X1439	23431113	X1501	32431342						
X1378	23132423	X1440	24312422	X1502	33123121						
X1379	32322433	X1441	33211211	X1503	33242213						
X1380	32112124	X1442	34211133	X1504	44231332						
X1381	13221342	X1443	34424423	X1505	12133121						
X1382	44221124	X1444	21122444	X1506	12243211						
X1383	42123431	X1445	12334324	X1507	32111231						
X1384	12344334	X1446	22231332	X1508	12312243						
X1385	24221331	X1447	13134233	X1509	12432123						
X1386	34234321	X1448	22344243	X1510	12333312						
X1387	24332233	X1449	13344234	X1511	22321121						
X1388	11224321	X1450	33121121	X1512	34423224						
X1389	43233234	X1451	23133422	X1513	34211342						
X1390	12442223	X1452	43342231	X1514	13243324						
X1391	13323422	X1453	33123211	X1515	12312311						
X1392	34312344	X1454	23421334	X1516	34224234						
X1393	42111333	X1455	12322123	X1517	12433232						
X1394	34212442	X1456	24434221	X1518	24243313						
X1395	23124311	X1457	43123322	X1519	21122123						
X1396	32332131	X1458	12322442	X1520	33212443						
X1397	22344344	X1459	23344244	X1521	31242433						
X1398	12243213	X1460	32344431	X1522	32134432						
X1399	13423322	X1461	24331344	X1523	12133244						
X1400	33111232	X1462	31124331	X1524	21313311						
X1401	13433121	X1463	12423112	X1525	21344332						
X1402	32211331	X1464	32432242	X1526	43134421						
X1403	12213324	X1465	32212312	X1527	34244223						
X1404	34342332	X1466	13313124	X1528	23423312						
X1405	33433222	X1467	32243433	X1529	24422343						
X1406	23321122	X1468	44311324	X1530	44311122						

**THE AXION EQUATION**

# LESS CUTTING =

**ANSI SOLUTION**

**3234**

*The Smallest Electric Strike in the World!*



**3478**





**AXION**  
PREMIUM ELECTRIC STRIKES

Perfect for either Aluminum or ANSI installations, all Trine 3000 strikes have the smallest backset available -- **only 1"**! The unique faceplate design of the 3234, 3258 and 3458, greatly reduce the expense of cutting by eliminating the need to enlarge standard strike plate openings. And don't forget the 3478 with its full lip design that reduces cutting and provides a standard strike plate finish. *The AXION solution can solve any strike problem you may face.*

[www.trineonline.com](http://www.trineonline.com)



718-829-2332



# Infiniti X1-X7000

X1618	34344213	X1647	23311123	X1676	32311332	X1705	22332132	X1767	32332342	X1829	22311333
X1619	22134233	X1648	22134422	X1677	23122121	X1706	23233443	X1768	34344233	X1830	23344312
X1620	34442122	X1649	33423243	X1678	13444213	X1707	23112324	X1769	31212434	X1831	13344344
X1621	31211334	X1650	22443122	X1679	32322134	X1708	11242334	X1770	43113132	X1832	33132422
X1622	33434223	X1651	34422434	X1680	43433212	X1709	31244312	X1771	12123122	X1833	11312424
X1623	11242431	X1652	13123431	X1681	21231322	X1710	44331331	X1772	42112334	X1834	32312344
X1624	13434223	X1653	33434421	X1682	31113232	X1711	11221124	X1773	24333243	X1835	32244421
X1625	42213213	X1654	44342243	X1683	34233122	X1712	21123221	X1774	31132244	X1836	34422313
X1626	13132112	X1655	33432131	X1684	12211331	X1713	42133223	X1775	24342243	X1837	32342323
X1627	24342223	X1656	13432131	X1685	31242442	X1714	31123332	X1776	13112422	X1838	34424221
X1628	44322111	X1657	34421231	X1686	24344333	X1715	23343113	X1777	31212313	X1839	44223331
X1629	12442313	X1658	22423434	X1687	42342331	X1716	21332322	X1778	12113213	X1840	32324323
X1630	24332444	X1659	11234342	X1688	13224424	X1717	21313224	X1779	13122324	X1841	22313212
X1631	44344223	X1660	21211331	X1689	31243344	X1718	42111344	X1780	31321213	X1842	43431212
X1632	42211231	X1661	21323223	X1690	42133344	X1719	42243234	X1781	23133444	X1843	13311221
X1633	42222343	X1662	23244223	X1691	21132322	X1720	13122124	X1782	43223123	X1844	44211213
X1634	42423421	X1663	22243313	X1692	33442334	X1721	21323322	X1783	33234434	X1845	32423442
X1635	13422134	X1664	23343221	X1693	11343422	X1722	33222442	X1784	23422133	X1846	34213122
X1636	24322113	X1665	23313321	X1694	42343112	X1723	42234234	X1785	22311133	X1847	22323112
X1637	34231342	X1666	13432133	X1695	23122233	X1724	33433422	X1786	34422331	X1848	42332112
X1638	32243442	X1667	21112331	X1696	43244421	X1725	31231213	X1787	13212331	X1849	33444222
X1639	13211132	X1668	23121124	X1697	24432443	X1726	43221213	X1788	23342433	X1850	24323224
X1640	33424312	X1669	42243342	X1698	13422422	X1727	13433422	X1789	31123431	X1851	11244321
X1641	42213343	X1670	34421233	X1699	31133113	X1728	31213213	X1790	42443131	X1852	42442233
X1642	12243321	X1671	22113223	X1700	32234334	X1729	44211132	X1791	33223311	X1853	13112231
X1643	12334221	X1672	31321132	X1701	32242432	X1730	11122443	X1792	11233123	X1854	23323421
X1644	32324422	X1673	11222433	X1702	43334223	X1731	11333243	X1793	13321231	X1855	33113232
X1645	44324421	X1674	44331131	X1703	12124424	X1732	42132444	X1794	34232433	X1856	44212443
X1646	24432421	X1675	44343222	X1704	33121134	X1733	42211312	X1795	21322134	X1857	44331311
						X1734	32113134	X1796	11334224	X1858	11343123
						X1735	22133434	X1797	22132244	X1859	42233132
						X1736	34242311	X1798	12244234	X1860	12312133
						X1737	24244343	X1799	33133221	X1861	23334243
						X1738	13211213	X1800	31134424	X1862	13113133
						X1739	31113423	X1801	22444231	X1863	32322444
						X1740	11222233	X1802	31124221	X1864	43423132
						X1741	34322211	X1803	21132423	X1865	12113424
						X1742	33312431	X1804	23322244	X1866	11334433
						X1743	24221131	X1805	42112224	X1867	13221131
						X1744	34321122	X1806	42221124	X1868	23123322
						X1745	22213334	X1807	42432131	X1869	43323421
						X1746	12212312	X1808	43432233	X1870	42121332
						X1747	12312212	X1809	43322244	X1871	13222312
						X1748	12442443	X1810	12134213	X1872	11231334
						X1749	31213343	X1811	13321233	X1873	32331222
						X1750	33344232	X1812	12442232	X1874	44223313
						X1751	22134242	X1813	32443422	X1875	43443134
						X1752	24344223	X1814	33443122	X1876	11342234
						X1753	43433432	X1815	13123444	X1877	12342242
						X1754	44212333	X1816	43213342	X1878	23443312
						X1755	32224331	X1817	21311343	X1879	43134434
						X1756	42212243	X1818	34423431	X1880	12333242
						X1757	33121334	X1819	33432122	X1881	33124234
						X1758	22442134	X1820	42342322	X1882	22323444
						X1759	22343323	X1821	32432424	X1883	42133243
						X1760	21244344	X1822	42343222	X1884	32132324
						X1761	32132223	X1823	43422322	X1885	42133421
						X1762	32223123	X1824	43443112	X1886	43443321
						X1763	31124434	X1825	12312124	X1887	42423342
						X1764	32431133	X1826	13444233	X1888	44221342
						X1765	24422244	X1827	33424213	X1889	13344243
						X1766	43122422	X1828	23211234	X1890	23113123

**THE AXION EQUATION**

# GREATER PROFIT.

**ALUMINUM SOLUTION**

3258



3458





**AXION**  
PREMIUM ELECTRIC STRIKES

You can install more of our AXION 3000 series strikes in a day than other strikes but there is more to it than just saving time! By cutting less of the frame, we give you a much stronger installation. Add to that our 1" backset and now you don't have to remove the dust box and concrete, which makes the frame even stronger! When you're finished with installation you will notice the final benefit: the best looking strike installation available. Ask yourself – isn't it time to try AXION?

[www.trineonline.com](http://www.trineonline.com)



718-829-2332

# Infiniti

## X1-X7000

X1891	31243421	X1953	43122134	X2015	21331334	X2077	13312323	X2139	22444334	X2201	42423434
X1892	12112234	X1954	24433433	X2016	24423423	X2078	31122313	X2140	31232434	X2202	22334424
X1893	31312433	X1955	34422311	X2017	42113221	X2079	12134243	X2141	23443233	X2203	23133242
X1894	22323312	X1956	12342321	X2018	34324321	X2080	31322113	X2142	33121224	X2204	21324213
X1895	13421312	X1957	23223321	X2019	32331134	X2081	43123434	X2143	32212433	X2205	42223342
X1896	43234224	X1958	13424211	X2020	33432434	X2082	21213342	X2144	22233112	X2206	42343422
X1897	34322332	X1959	44342232	X2021	42432122	X2083	43432134	X2145	32322424	X2207	42134433
X1898	23234224	X1960	23123421	X2022	13432434	X2084	22213332	X2146	43442342	X2208	13323442
X1899	22332312	X1961	44213323	X2023	33224431	X2085	44312422	X2147	32231243	X2209	32212231
X1900	11234421	X1962	12324321	X2024	23421123	X2086	12342422	X2148	21344321	X2210	43442111
X1901	43243224	X1963	23123243	X2025	44221331	X2087	22431132	X2149	22433211	X2211	23432211
X1902	31332424	X1964	21321344	X2026	21333222	X2088	24342232	X2150	21321131	X2212	42344322
X1903	44312242	X1965	23211223	X2027	44333124	X2089	32234244	X2151	22322313	X2213	21313343
X1904	43422344	X1966	43432242	X2028	12333213	X2090	24243122	X2152	33421131	X2214	44231242
X1905	21233342	X1967	34223132	X2029	33213242	X2091	24234243	X2153	21343223	X2215	24423331
X1906	13224343	X1968	13211242	X2030	12344211	X2092	33122421	X2154	12231133	X2216	22311344
X1907	32123342	X1969	12234321	X2031	31131133	X2093	44344232	X2155	34322233	X2217	21233331
X1908	24313212	X1970	11133312	X2032	24334233	X2094	24442112	X2156	43423422	X2218	11223124
X1909	42331344	X1971	12343221	X2033	34312232	X2095	33422442	X2157	21132331	X2219	24322313
X1910	44433112	X1972	13231224	X2034	34211122	X2096	12434222	X2158	12344343	X2220	31332132
X1911	13423223	X1973	24331113	X2035	43342323	X2097	13243432	X2159	233432124	X2221	13312442
X1912	34244342	X1974	24333423	X2036	12133123	X2098	22443223	X2160	31223322	X2222	34231243
X1913	32431113	X1975	21133222	X2037	33234221	X2099	32233324	X2161	44244222	X2223	21312434
X1914	33231211	X1976	31222233	X2038	13312123	X2100	43213322	X2162	31112424	X2224	34213243
X1915	33312132	X1977	31312233	X2039	22432124	X2101	33442132	X2163	24424332	X2225	21224331
X1916	31322131	X1978	13443234	X2040	12343113	X2102	33312312	X2164	32213243	X2226	24323424
X1917	24221113	X1979	34244232	X2041	23311332	X2103	22234434	X2165	24443234	X2227	32431234
X1918	21122332	X1980	43443121	X2042	13221113	X2104	31212432	X2166	12313323	X2228	22233211
X1919	32222331	X1981	31112433	X2043	31234234	X2105	32433124	X2167	22213431	X2229	43221231
X1920	32432334	X1982	13443113	X2044	33213431	X2106	12213122	X2168	13421133	X2230	32332311
X1921	23224342	X1983	33224231	X2045	24442231	X2107	22122313	X2169	24443113	X2231	22433244
X1922	44232212	X1984	34223321	X2046	43243211	X2108	13433444	X2170	43132131	X2232	24442121
X1923	42313344	X1985	43442322	X2047	13424424	X2109	44243113	X2171	33423311	X2233	23133431
X1924	13433123	X1986	24313311	X2048	12443343	X2110	33421324	X2172	34233232	X2234	23334443
X1925	34322343	X1987	24334211	X2049	21332434	X2111	32234433	X2173	12132342	X2235	12244333
X1926	43442131	X1988	44242231	X2050	23111224	X2112	33221243	X2174	24322331	X2236	44423322
X1927	43121333	X1989	33222343	X2051	43222234	X2113	24213213	X2175	42433222	X2237	24344232
X1928	42334321	X1990	12422421	X2052	43311211	X2114	43332434	X2176	32312122	X2238	13122432
X1929	21342442	X1991	23211311	X2053	34334243	X2115	31213222	X2177	43132133	X2239	23324224
X1930	13243113	X1992	22342313	X2054	43121322	X2116	22233213	X2178	24243342	X2240	34434332
X1931	33113423	X1993	44323323	X2055	44432113	X2117	23424322	X2179	24334242	X2241	21112243
X1932	31224231	X1994	23322321	X2056	44221312	X2118	43423334	X2180	43421233	X2242	33421313
X1933	11223322	X1995	44222334	X2057	34243343	X2119	44232111	X2181	13112442	X2243	44321121
X1934	21343344	X1996	23342442	X2058	11331234	X2120	23121344	X2182	32233423	X2244	13213213
X1935	12443224	X1997	43432121	X2059	33322324	X2121	43124433	X2183	24432113	X2245	12442124
X1936	32211212	X1998	23443244	X2060	32442243	X2122	33133124	X2184	44331243	X2246	24243234
X1937	23132232	X1999	42223443	X2061	21133321	X2123	21133231	X2185	32433223	X2247	33221122
X1938	42332424	X2000	21322444	X2062	42323422	X2124	33312444	X2186	12231331	X2248	34324334
X1939	23223132	X2001	24422134	X2063	23244342	X2125	33212243	X2187	43231243	X2249	12434231
X1940	11333423	X2002	43321221	X2064	22132213	X2126	32322431	X2188	11324221	X2250	12211223
X1941	42423324	X2003	43124211	X2065	42122421	X2127	24224231	X2189	23231243	X2251	11122333
X1942	32421334	X2004	44224233	X2066	42131243	X2128	12211234	X2190	12324334	X2252	44313324
X1943	43442133	X2005	23344332	X2067	34232334	X2129	12322321	X2191	33221324	X2253	44211321
X1944	22342432	X2006	22334244	X2068	24311221	X2130	12423422	X2192	32421312	X2254	43244311
X1945	22123121	X2007	12134443	X2069	21224344	X2131	12334344	X2193	11342223	X2255	43221233
X1946	31221124	X2008	42132123	X2070	42234232	X2132	21124231	X2194	22233312	X2256	42332132
X1947	33433424	X2009	33113212	X2071	44423124	X2133	24213343	X2195	12311343	X2257	21343121
X1948	23312443	X2010	43311132	X2072	44311124	X2134	23244232	X2196	11222444	X2258	43433243
X1949	21333123	X2011	22112433	X2073	12443211	X2135	42313243	X2197	42432434	X2259	32312331
X1950	43321124	X2012	22333324	X2074	44322434	X2136	13124333	X2198	13243344	X2260	23113422
X1951	42233231	X2013	13243212	X2075	33213442	X2137	22113324	X2199	21332331	X2261	13213343
X1952	21122343	X2014	31312244	X2076	11334334	X2138	33423111	X2200	22213442	X2262	13324234



# Infiniti X1-X7000

X2263	23331222	X2325	11322324	X2387	43432424
X2264	34224331	X2326	12231113	X2388	33113113
X2265	23322112	X2327	43124312	X2389	24424233
X2266	13343312	X2328	23424324	X2390	44342313
X2267	33232131	X2329	34423121	X2391	31121343
X2268	44331324	X2330	33222213	X2392	34432312
X2269	23422443	X2331	42322423	X2393	24233132
X2270	43324213	X2332	33421223	X2394	13132231
X2271	43311343	X2333	11344322	X2395	13223131
X2272	34234242	X2334	33221313	X2396	23131242
X2273	44432221	X2335	34212244	X2397	12331334
X2274	23243431	X2336	32243332	X2398	42122344
X2275	31213311	X2337	21321113	X2399	44343242
X2276	32442311	X2338	42242213	X2400	32243242
X2277	11221342	X2339	24312334	X2401	23213423
X2278	12323342	X2340	11212344	X2402	42343123
X2279	34331213	X2341	33421113	X2403	33111344
X2280	42323424	X2342	24322311	X2404	12323124
X2281	23213342	X2343	32223312	X2405	12322112
X2282	42432324	X2344	22343213	X2406	11332131
X2283	11233224	X2345	23433221	X2407	12224342
X2284	21231223	X2346	12132434	X2408	31211332
X2285	42224323	X2347	34423244	X2409	31234232
X2286	21322424	X2348	21342332	X2410	43233113
X2287	44324221	X2349	44233233	X2411	23331231
X2288	12342431	X2350	31311221	X2412	11221331
X2289	32213324	X2351	44312323	X2413	23221121
X2290	21231113	X2352	11213323	X2414	34224423
X2291	42422442	X2353	13133234	X2415	42111234
X2292	34433311	X2354	23133213	X2416	34431232
X2293	12212332	X2355	22243342	X2417	21124321
X2294	33443223	X2356	33242431	X2418	22134231
X2295	23112113	X2357	21321311	X2419	13234243
X2296	21342123	X2358	42131223	X2420	43324332
X2297	23312221	X2359	42431222	X2421	33113122
X2298	24324234	X2360	33124342	X2422	32434332
X2299	33124432	X2361	21324332	X2423	32121344
X2300	34212233	X2362	24231121	X2424	32244311
X2301	23113433	X2363	32111224	X2425	22243234
X2302	31321231	X2364	31344342	X2426	32132221
X2303	21313442	X2365	42212443	X2427	21342224
X2304	32122442	X2366	33432432	X2428	13243421
X2305	22344423	X2367	21213322	X2429	12431124
X2306	12244243	X2368	12242311	X2430	23112333
X2307	34221233	X2369	13313221	X2431	21132232
X2308	44323442	X2370	13343442	X2432	44431222
X2309	22423421	X2371	33424231	X2433	24333212
X2310	24321323	X2372	22311324	X2434	31332312
X2311	43121131	X2373	22344313	X2435	22111322
X2312	12233421	X2374	21123322	X2436	33213321
X2313	32344433	X2375	33213244	X2437	22311122
X2314	12433221	X2376	43223312	X2438	32223121
X2315	21334232	X2377	44333311	X2439	44213312
X2316	24343343	X2378	21134342	X2440	12334322
X2317	21134432	X2379	32221121	X2441	33311344
X2318	21231311	X2380	31231312	X2442	11213221
X2319	22233244	X2381	43423424	X2443	11133324
X2320	34443224	X2382	22431224	X2444	23223433
X2321	33432243	X2383	32442232	X2445	31223124
X2322	31321233	X2384	11122213	X2446	24424312
X2323	13432243	X2385	32233434	X2447	24331232
X2324	42313423	X2386	42221342	X2448	33242334

## Competitor Trade-In Program

### 1 MONTH ONLY!

If you are the owner of a blue key programmer called Sdd and would like to trade it in to get a T-Code, now is the time to do so.

## JULY 2004



- Supply us with your receipts for the unit along with any software you may have purchased.
- We will trade you for a T-Code with comparable software. • Cost is \$800 + shipping. • You must be the legal owner of the unit and sign a release when you present your full kit to us for a trade-in to T-Code.

- See us at ALOA for more details or call us @ Tel: 650-616-1941 • Trade-in program to be administered by T-Code Tech Support.

- Supply is limited. • Trade-in program is void where prohibited.

- Any taxes owed because of this offer is the responsibility of the trade-in client. • T-Code Tech Support reserves the right to refuse this offer to anyone.

- C.A.N. system is built in. No external unit. • Largest support for key & remote programming. • Easy to use interface. • Comprehensive User's Manual that is Easy to use and well written. Some Software may require additional purchase, for specific details contact T-Code Tech Support.

**T-Code is the leader in the U.S. and around the world.**



Circle 283 on Rapid Reply

# Infiniti

## X1-X7000

X2449	21343324	X2511	33243322	X2573	31132334	X2635	21324312	X2697	12332122	X2759	43233432
X2450	12222344	X2512	42211224	X2574	12243224	X2636	31221331	X2698	11321134	X2760	44343112
X2451	21123421	X2513	23431221	X2575	34431212	X2637	43223233	X2699	22312233	X2761	32334311
X2452	22343211	X2514	24231334	X2576	42333324	X2638	31221221	X2700	24431231	X2762	32424432
X2453	13424321	X2515	31342313	X2577	43131121	X2639	21124334	X2701	43324312	X2763	33122122
X2454	12432244	X2516	24223443	X2578	24423324	X2640	34311343	X2702	43443132	X2764	34332122
X2455	44224321	X2517	42221331	X2579	23421311	X2641	31242213	X2703	12432444	X2765	21133442
X2456	12233234	X2518	43312342	X2580	34344231	X2642	33344234	X2704	33132442	X2766	13124443
X2457	21123243	X2519	13423313	X2581	43123313	X2643	31121321	X2705	23313444	X2767	12213223
X2458	13443243	X2520	31324313	X2582	31344223	X2644	33234421	X2706	22134321	X2768	34432211
X2459	13321332	X2521	34231223	X2583	22423342	X2645	43243134	X2707	31222431	X2769	43442122
X2460	42332312	X2522	24244224	X2584	43211124	X2646	11244233	X2708	24334222	X2770	42433424
X2461	34443211	X2523	21221233	X2585	24433224	X2647	31224213	X2709	22234342	X2771	24211134
X2462	43223121	X2524	13132424	X2586	32131244	X2648	12342134	X2710	24311331	X2772	44311221
X2463	42331113	X2525	33344311	X2587	33311324	X2649	24231231	X2711	23342312	X2773	42334424
X2464	43422243	X2526	33431211	X2588	34212112	X2650	43134234	X2712	11334442	X2774	42443324
X2465	33223234	X2527	43124343	X2589	42322324	X2651	22322133	X2713	43423112	X2775	42123444
X2466	31342432	X2528	32312232	X2590	22331344	X2652	12334223	X2714	23443134	X2776	34213311
X2467	11342124	X2529	23133121	X2591	33433121	X2653	33321211	X2715	24321343	X2777	42134332
X2468	12313424	X2530	24234342	X2592	12321333	X2654	33311122	X2716	11342132	X2778	23223112
X2469	24434421	X2531	24343242	X2593	43244313	X2655	12433344	X2717	22443313	X2779	43344211
X2470	24233231	X2532	43322123	X2594	43243112	X2656	12313312	X2718	24322133	X2780	44324333
X2471	22342133	X2533	44432423	X2595	32443343	X2657	32221134	X2719	32421134	X2781	12243442
X2472	12112313	X2534	12113123	X2596	22113434	X2658	12243323	X2720	23443321	X2782	21233232
X2473	32344422	X2535	21234224	X2597	24331212	X2659	34424322	X2721	33342342	X2783	12333422
X2474	32234431	X2536	11344324	X2598	22132334	X2660	23442331	X2722	24323244	X2784	32223431
X2475	43124431	X2537	42111223	X2599	44313212	X2661	42312444	X2723	13211323	X2785	43112331
X2476	44331223	X2538	43322442	X2600	11312224	X2662	21132124	X2724	43133222	X2786	34221334
X2477	11243313	X2539	22331212	X2601	12424313	X2663	12123443	X2725	22312244	X2787	24433442
X2478	43111321	X2540	13242134	X2602	42422132	X2664	23243312	X2726	33213123	X2788	12232444
X2479	32433324	X2541	31131243	X2603	33124421	X2665	11233424	X2727	34233131	X2789	24234421
X2480	32443224	X2542	33111324	X2604	32124424	X2666	24443243	X2728	13342342	X2790	13212133
X2481	34223433	X2543	42132312	X2605	22334321	X2667	23443112	X2729	24223342	X2791	13344423
X2482	23231223	X2544	32132443	X2606	42431312	X2668	33324432	X2730	24332242	X2792	11132244
X2483	23431133	X2545	23123434	X2607	43211133	X2669	33212313	X2731	11332332	X2793	11242244
X2484	32442324	X2546	42133212	X2608	44234223	X2670	13223221	X2732	13123231	X2794	22432111
X2485	32132421	X2547	22332112	X2609	22211334	X2671	33132431	X2733	12321322	X2795	24323321
X2486	13311331	X2548	42324313	X2610	34211124	X2672	33134244	X2734	13232131	X2796	32231342
X2487	33444323	X2549	22332244	X2611	43323311	X2673	23344321	X2735	32421332	X2797	33244323
X2488	12213243	X2550	23133244	X2612	12231211	X2674	23111343	X2736	32111233	X2798	13134242
X2489	42211343	X2551	33342322	X2613	12324433	X2675	13324443	X2737	44322124	X2799	12123124
X2490	32331123	X2552	32344332	X2614	31344421	X2676	43333424	X2738	44332213	X2800	22434234
X2491	12232231	X2553	43443123	X2615	13213222	X2677	31133324	X2739	43122224	X2801	42321323
X2492	11333324	X2554	42233431	X2616	33211231	X2678	44422132	X2740	33131243	X2802	22322113
X2493	13312343	X2555	33112442	X2617	42133311	X2679	33224224	X2741	21324231	X2803	32442124
X2494	23124332	X2556	32131233	X2618	34233324	X2680	13134422	X2742	43222311	X2804	43324231
X2495	31334224	X2557	24431222	X2619	23432231	X2681	34324433	X2743	13123311	X2805	21223444
X2496	32113323	X2558	23313211	X2620	34213331	X2682	43324442	X2744	34422421	X2806	34223112
X2497	23342132	X2559	34332131	X2621	11231132	X2683	23324442	X2745	43221334	X2807	43223431
X2498	21221231	X2560	22213321	X2622	12133334	X2684	11324333	X2746	43312234	X2808	23442322
X2499	22213244	X2561	42222134	X2623	32344233	X2685	42442343	X2747	43422223	X2809	22112431
X2500	22244431	X2562	42334244	X2624	23344224	X2686	31322313	X2748	13442224	X2810	24211334
X2501	42432243	X2563	43234213	X2625	43213313	X2687	12332234	X2749	33211312	X2811	34234424
X2502	31221342	X2564	13433431	X2626	42113432	X2688	44431312	X2750	23442131	X2812	43333242
X2503	42433334	X2565	24213132	X2627	32122312	X2689	34342132	X2751	12231324	X2813	12223323
X2504	44312442	X2566	23234213	X2628	13244222	X2690	23324312	X2752	42133131	X2814	24431312
X2505	12431344	X2567	22211134	X2629	43222313	X2691	33423122	X2753	32242331	X2815	44332332
X2506	34213223	X2568	31232232	X2630	21324442	X2692	13213132	X2754	12232132	X2816	22133344
X2507	12444212	X2569	44431231	X2631	21342312	X2693	13332242	X2755	13312211	X2817	11213312
X2508	44212243	X2570	42311221	X2632	22322131	X2694	24324443	X2756	34332234	X2818	31131223
X2509	31124344	X2571	22113311	X2633	32121122	X2695	22112323	X2757	32244313	X2819	23422342
X2510	33442343	X2572	23224434	X2634	22324432	X2696	32131242	X2758	23334423	X2820	23121243



# Infiniti X1-X7000

X2821	33221124	X2883	12234242	X2945	24432223	X3007	23113343	X3036	31332244	X3065	22112343
X2822	31244242	X2884	11344212	X2946	24342131	X3008	12224434	X3037	13342344	X3066	23312434
X2823	44242343	X2885	44243324	X2947	33324421	X3009	11323123	X3038	12442113	X3067	32211342
X2824	44211323	X2886	33211123	X2948	31311331	X3010	42134442	X3039	33112321	X3068	32422113
X2825	21311231	X2887	34213133	X2949	21342433	X3011	31221131	X3040	23213313	X3069	22442442
X2826	33222231	X2888	22432342	X2950	11312233	X3012	44421131	X3041	43332111	X3070	13423344
X2827	12242432	X2889	43443323	X2951	12333424	X3013	24343222	X3042	13113124	X3071	24313344
X2828	31312224	X2890	42221131	X2952	13122342	X3014	24434311	X3043	12421334	X3072	12122323
X2829	44342131	X2891	22442433	X2953	11224431	X3015	42132422	X3044	31112343	X3073	12223424
X2830	44432223	X2892	33224433	X2954	22331133	X3016	42244431	X3045	42432133	X3074	31223131
X2831	42433332	X2893	31211213	X2955	33212432	X3017	32211234	X3046	42132433	X3075	44432124
X2832	42234311	X2894	33442233	X2956	12423442	X3018	12431223	X3047	23113242	X3076	31244332
X2833	24334231	X2895	23124431	X2957	12244421	X3019	42234212	X3048	23342211	X3077	13113443
X2834	23321344	X2896	21122424	X2958	31342133	X3020	13113421	X3049	32231322	X3078	43232112
X2835	34424324	X2897	24332422	X2959	32113442	X3021	32444212	X3050	23321234	X3079	23233212
X2836	44323343	X2898	42323442	X2960	12444221	X3022	24421243	X3051	12431122	X3080	32133321
X2837	11331221	X2899	12334331	X2961	23312324	X3023	34213113	X3052	43212334	X3081	44421313
X2838	22213123	X2900	12443231	X2962	32431322	X3024	33424224	X3053	43321234	X3082	32422423
X2839	44342133	X2901	12113433	X2963	44334321	X3025	43111323	X3054	44222244	X3083	33122423
X2840	24442332	X2902	43431232	X2964	21221334	X3026	13312422	X3055	21344242	X3084	23313242
X2841	31222132	X2903	31122423	X2965	43134232	X3027	23211133	X3056	31212234	X3085	33344243
X2842	13344313	X2904	34312122	X2966	24322432	X3028	24331133	X3057	32433432	X3086	24344234
X2843	22133223	X2905	42133122	X2967	32213113	X3029	21121344	X3058	13311232	X3087	21113323
X2844	23312223	X2906	34234231	X2968	44421324	X3030	24224433	X3059	23133123	X3088	11342423
X2845	43343212	X2907	42331232	X2969	34233221	X3031	13113243	X3060	42331212	X3089	42433312
X2846	32113224	X2908	34421211	X2970	43221312	X3032	24233431	X3061	42332244	X3090	44342111
X2847	32422333	X2909	23424311	X2971	43422313	X3033	32424421	X3062	32334432	X3091	42232131
X2848	23422324	X2910	33222134	X2972	34233111	X3034	43333211	X3063	13234421	X3092	43222443
X2849	43133231	X2911	11224231	X2973	24344311	X3035	42343121	X3064	13343321	X3093	43422432
X2850	13312242	X2912	32422131	X2974	22311124						
X2851	31224433	X2913	33231134	X2975	34312331						
X2852	44344311	X2914	43233443	X2976	32433212						
X2853	34244234	X2915	33223421	X2977	34212134						
X2854	22132444	X2916	34334423	X2978	11312244						
X2855	42211233	X2917	24244323	X2979	43423233						
X2856	21312313	X2918	31334312	X2980	43113444						
X2857	33321224	X2919	24321123	X2981	32243111						
X2858	44213231	X2920	22333421	X2982	11233134						
X2859	12431131	X2921	32212431	X2983	34324431						
X2860	21213313	X2922	22324421	X2984	44312211						
X2861	21334434	X2923	31321332	X2985	23244234						
X2862	44242132	X2924	23431234	X2986	12213311						
X2863	34423123	X2925	24332433	X2987	12342131						
X2864	34421132	X2926	32422133	X2988	33444211						
X2865	24343112	X2927	22234421	X2989	12221334						
X2866	22233433	X2928	32113431	X2990	32431221						
X2867	13332422	X2929	12313244	X2991	22122131						
X2868	23324343	X2930	21321223	X2992	22133243						
X2869	42343244	X2931	22124443	X2993	42113342						
X2870	44222112	X2932	42244211	X2994	32133222						
X2871	34342312	X2933	12324431	X2995	32213122						
X2872	43243231	X2934	32243132	X2996	32131334						
X2873	11343312	X2935	23434224	X2997	34221312						
X2874	23224313	X2936	13311243	X2998	21123434						
X2875	44343121	X2937	42213211	X2999	33322423						
X2876	12113422	X2938	13223124	X3000	22431334						
X2877	32112331	X2939	24321321	X3001	44234322						
X2878	21122431	X2940	32113312	X3002	31211244						
X2879	34312113	X2941	12133332	X3003	23321131						
X2880	22243243	X2942	13444334	X3004	11223113						
X2881	44423113	X2943	13222112	X3005	44212313						
X2882	31334431	X2944	32244344	X3006	42112321						

Your Reliable Hardware Supplier

Get  
It  
Quick!

We have it before you need it!!



To Order Call Toll Free

Phone: 800.238.4566

Fax: 800.538.4566

Call or Write for our  
FREE Full Line Catalog

Omaha Wholesale Hardware  
P.O. Box 3628  
Omaha, Nebraska 68103  
Web: OMAHAWH.com  
Email: SALES@OMAHAWH.com

Adams Rite  
Alarm Lock  
CCL  
Chicago Lock  
Detex  
Dor-O-Matic  
ESP  
Folger Adam  
Fort Lock  
Glynn Johnson  
Hager  
HPC  
KABA ILCO  
Ives  
Jackson  
Jet  
LAB  
LCN  
Locknetics  
Lucky Line  
MAG  
Master Lock  
Medeco  
National Cabinet Lock  
National Guard  
Norton  
Rixson  
Rockwood  
Roton  
Sargent  
Schlage  
Simplex  
Stanley  
Telkey  
Von Duprin  
Washroom Accessories

# Infiniti

## X1-X7000

X3094	23211342	X3156	42321343	X3218	44221221	X3280	13442211	X3342	24224431	X3404	12333244
X3095	23112234	X3157	13124321	X3219	34342211	X3281	21211234	X3343	22443342	X3405	43242313
X3096	43331213	X3158	12122132	X3220	31132213	X3282	32234321	X3344	44223342	X3406	22344432
X3097	31231224	X3159	11332321	X3221	13112242	X3283	13113223	X3345	23423211	X3407	43433113
X3098	13433134	X3160	33312112	X3222	31223113	X3284	43343342	X3346	43422221	X3408	42213332
X3099	13122434	X3161	23434424	X3223	43311231	X3285	22442323	X3347	21344213	X3409	24213211
X3100	23213221	X3162	13122234	X3224	31122331	X3286	34433322	X3348	43421132	X3410	34424311
X3101	42334332	X3163	23321113	X3225	42344221	X3287	42131342	X3349	23113244	X3411	24223423
X3102	12122334	X3164	32121124	X3226	11231233	X3288	33244242	X3350	43343113	X3412	32431331
X3103	13442321	X3165	32212332	X3227	24433112	X3289	44244211	X3351	42433121	X3413	33112231
X3104	23421121	X3166	11324223	X3228	32433443	X3290	34224344	X3352	33231123	X3414	32443231
X3105	22331113	X3167	22131243	X3229	12433133	X3291	22342311	X3353	32332423	X3415	43421343
X3106	31243313	X3168	43113213	X3230	33321244	X3292	12211133	X3354	24234221	X3416	31233242
X3107	33444312	X3169	12311231	X3231	21244212	X3293	43343221	X3355	34321131	X3417	33224332
X3108	42132233	X3170	44421223	X3232	13242211	X3294	43243442	X3356	13432212	X3418	22424332
X3109	43212132	X3171	43122213	X3233	21332221	X3295	22442231	X3357	32233124	X3419	12332232
X3110	43333244	X3172	11233321	X3234	11342113	X3296	11311232	X3358	32423323	X3420	21323344
X3111	22434232	X3173	12323113	X3235	31113443	X3297	32332344	X3359	12211342	X3421	32112243
X3112	31211242	X3174	42242431	X3236	31211222	X3298	44332134	X3360	31224332	X3422	42122313
X3113	42232133	X3175	32243334	X3237	42242231	X3299	22134433	X3361	33113243	X3423	43324224
X3114	34231322	X3176	33442213	X3238	43334432	X3300	42112422	X3362	21324224	X3424	24244242
X3115	24442312	X3177	44421113	X3239	22243124	X3301	43112243	X3363	23421134	X3425	32342442
X3116	22132123	X3178	31121323	X3240	43224443	X3302	42332213	X3364	43213421	X3426	33211343
X3117	34422122	X3179	31224431	X3241	23423213	X3303	43332221	X3365	44333322	X3427	13322423
X3118	34334324	X3180	44432311	X3242	13124324	X3304	22322331	X3366	23322343	X3428	12432132
X3119	12333444	X3181	11311243	X3243	11322423	X3305	34244243	X3367	32344231	X3429	43213443
X3120	31334213	X3182	43111231	X3244	12444333	X3306	11122124	X3368	31122311	X3430	13234434
X3121	34232244	X3183	21124422	X3245	31134244	X3307	44433332	X3369	42321123	X3431	23444331
X3122	31244213	X3184	33311124	X3246	44324223	X3308	34431342	X3370	34222432	X3432	22124324
X3123	43243433	X3185	43243323	X3247	44332321	X3309	21231133	X3371	31124423	X3433	23132243
X3124	34432231	X3186	34321344	X3248	34244333	X3310	22123433	X3372	33421331	X3434	33322122
X3125	31234311	X3187	22113234	X3249	24231332	X3311	44212432	X3373	44243212	X3435	13331234
X3126	12331134	X3188	13422233	X3250	43224333	X3312	31234212	X3374	33113124	X3436	21113224
X3127	21223332	X3189	31113421	X3251	34443231	X3313	23443123	X3375	34332311	X3437	42333421
X3128	12442324	X3190	12311233	X3252	22122331	X3314	12344323	X3376	12234424	X3438	43133442
X3129	12213133	X3191	31113243	X3253	43243123	X3315	21112333	X3377	13123213	X3439	24423421
X3130	11331342	X3192	44234324	X3254	44322333	X3316	43224243	X3378	23312432	X3440	13134431
X3131	31322133	X3193	42342342	X3255	33421342	X3317	22423133	X3379	44223324	X3441	23432224
X3132	11243342	X3194	11243234	X3256	11231244	X3318	12323311	X3380	23421332	X3442	43322112
X3133	42312332	X3195	31123444	X3257	12243134	X3319	34334221	X3381	23342242	X3443	22321334
X3134	12112443	X3196	32113233	X3258	24311232	X3320	23432123	X3382	23244333	X3444	22322311
X3135	32211223	X3197	23322211	X3259	13222334	X3321	13211321	X3383	21223134	X3445	23332212
X3136	43123344	X3198	43322321	X3260	42242334	X3322	33112422	X3384	42112231	X3446	13443131
X3137	24234434	X3199	22112213	X3261	33444332	X3323	31121231	X3385	33223111	X3447	21233122
X3138	32133231	X3200	24432124	X3262	12213113	X3324	22244433	X3386	24424422	X3448	12233113
X3139	24311243	X3201	43211122	X3263	33132242	X3325	12333211	X3387	42133432	X3449	23244243
X3140	44322421	X3202	43322211	X3264	42123121	X3326	33221342	X3388	42243243	X3450	11323224
X3141	12234332	X3203	24231132	X3265	23243422	X3327	34232134	X3389	12132131	X3451	31113223
X3142	12112322	X3204	22123323	X3266	32331244	X3328	12434312	X3390	21322244	X3452	24313423
X3143	12331332	X3205	11332134	X3267	32132234	X3329	42442213	X3391	32312443	X3453	43232132
X3144	24422211	X3206	12133134	X3268	31244233	X3330	22111243	X3392	34211322	X3454	33122313
X3145	23334221	X3207	43232231	X3269	23311244	X3331	31223221	X3393	12123131	X3455	22111232
X3146	13223344	X3208	13242332	X3270	43132223	X3332	42342333	X3394	44231312	X3456	13212333
X3147	43224223	X3209	44332121	X3271	31223313	X3333	32312113	X3395	42321321	X3457	13423423
X3148	11331312	X3210	11231231	X3272	31332213	X3334	11344221	X3396	43421211	X3458	33223434
X3149	32211311	X3211	22432344	X3273	44233334	X3335	21211342	X3397	34321234	X3459	33312231
X3150	42311331	X3212	24323422	X3274	24313243	X3336	21231331	X3398	33244312	X3460	11322342
X3151	44223443	X3213	22433433	X3275	33243311	X3337	22442112	X3399	31311243	X3461	42212434
X3152	44431134	X3214	33322342	X3276	43122321	X3338	13231134	X3400	21321333	X3462	33221331
X3153	43212442	X3215	12243112	X3277	23224234	X3339	12432332	X3401	21211223	X3463	42121132
X3154	22122113	X3216	34242331	X3278	22432234	X3340	22211332	X3402	43131132	X3464	42231121
X3155	21334234	X3217	32331231	X3279	33124313	X3341	13223243	X3403	44343123	X3465	23342321



# Infiniti X1-X7000

X3466	33322243	X3528	21113431	X3590	12212444
X3467	44224213	X3529	34321113	X3591	42212311
X3468	24322234	X3530	42324344	X3592	24432221
X3469	31242431	X3531	21233221	X3593	34311231
X3470	12322332	X3532	21312322	X3594	42313223
X3471	11133234	X3533	13422433	X3595	12132122
X3472	22434423	X3534	24343123	X3596	22244211
X3473	34434422	X3535	32433243	X3597	13421344
X3474	13244433	X3536	23344242	X3598	44422121
X3475	42212313	X3537	34332421	X3599	23342422
X3476	33242244	X3538	33443342	X3600	13242242
X3477	43233223	X3539	31213332	X3601	34332443
X3478	12332421	X3540	44333342	X3602	34423343
X3479	43221211	X3541	34231133	X3603	33132112
X3480	12423321	X3542	43212213	X3604	44211211
X3481	42213242	X3543	42123321	X3605	43322233
X3482	31331221	X3544	23442421	X3606	22113331
X3483	33233242	X3545	13213211	X3607	34322224
X3484	32444221	X3546	21113312	X3608	24221234
X3485	42331133	X3547	31242231	X3609	33422132
X3486	23311323	X3548	11342243	X3610	33244213
X3487	43442333	X3549	24422233	X3611	34311233
X3488	22342324	X3550	24244312	X3612	31213242
X3489	43232444	X3551	31123213	X3613	32421121
X3490	34332232	X3552	31232113	X3614	11313324
X3491	22343224	X3553	12123113	X3615	34331224
X3492	12222313	X3554	12344244	X3616	42231334
X3493	31324344	X3555	24344243	X3617	43122433
X3494	12322343	X3556	32331121	X3618	44431123
X3495	23221343	X3557	21344431	X3619	44233332
X3496	12234231	X3558	34321311	X3620	44342122
X3497	21323443	X3559	23121333	X3621	33242231
X3498	12244311	X3560	22331232	X3622	44234423
X3499	23231133	X3561	32442113	X3623	44221131
X3500	34221332	X3562	33324221	X3624	24434223
X3501	32324334	X3563	12342233	X3625	11234344
X3502	23311222	X3564	24224332	X3626	12223343
X3503	23424223	X3565	23123344	X3627	13243313
X3504	34221211	X3566	31222343	X3628	22423311
X3505	42433231	X3567	13123121	X3629	12113343
X3506	23423134	X3568	21113442	X3630	32213223
X3507	32123443	X3569	23434213	X3631	32231223
X3508	34421244	X3570	11224313	X3632	42311243
X3509	43423321	X3571	31242334	X3633	42133322
X3510	23312421	X3572	33244332	X3634	22133212
X3511	13224442	X3573	13132121	X3635	12421123
X3512	22312132	X3574	34433423	X3636	32134421
X3513	43242311	X3575	11224224	X3637	43342442
X3514	11223432	X3576	33122311	X3638	11233422
X3515	11132334	X3577	33312134	X3639	32231113
X3516	42342344	X3578	34231331	X3640	11223344
X3517	42333221	X3579	43112212	X3641	22113344
X3518	43113222	X3580	12331123	X3642	33124221
X3519	22213323	X3581	44243131	X3643	13244422
X3520	31321211	X3582	23422124	X3644	34222333
X3521	31311232	X3583	33124434	X3645	44422321
X3522	42422121	X3584	11223121	X3646	23211122
X3523	12124442	X3585	22423111	X3647	43421224
X3524	31222332	X3586	23444322	X3648	22311221
X3525	12232112	X3587	34342242	X3649	13311212
X3526	21321322	X3588	42133443	X3650	23331244
X3527	12332443	X3589	23122134	X3651	32423431

## KEDEX

### Armored Door Loops

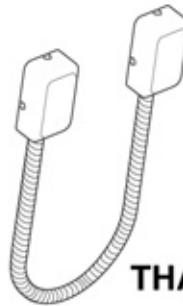

More sizes: 1/4" & 3/8".

More lengths: 18, 24",  
30", 45" & 60".

More colors: Aluminum,  
Duro, Gold, Black & White.

**THAN ANY OTHER BRAND!**

**Now Available: Keedex K-DS  
All Stainless Steel Door Loop.**



## KEDEX

### Weldable Gate Boxes

With more than eighty different models available, Keedex has a solution for your gate lock installation. Keedex Weldable Gate Boxes are available for cylindrical locks, deadbolts, mortise locks, push-button locks, lever locks, hotel locks, electric strikes and more.

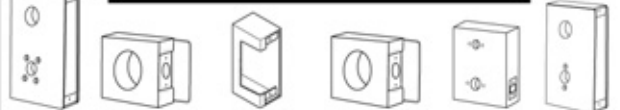

### The Door Laser

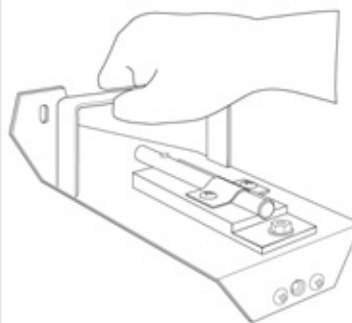

The Affordable  
& Effective Tool  
For Core Drilling  
Doors.

Laser Sight For  
Accurate Drilling.  
1/4" Bit For Pilot  
Hole Included.

Available From  
Your Distributor.

## KEDEX

Call or write today  
for your free catalog!

Keedex, Inc.  
12931 Shackelford Lane  
Garden Grove, CA 92841  
714-636-5657  
Fax: 714-636-5680  
e-mail: info@keedex.com  
www.keedex.com

# Infiniti X1-X7000

X3652	43333422	X3680	31324331	X3708	34231113	X3736	43123331	X3798	32342123	X3860	12342213
X3653	43233243	X3681	43122231	X3709	33224312	X3737	13223113	X3799	31243342	X3861	11231332
X3654	24443131	X3682	44342311	X3710	32112212	X3738	33121332	X3800	42133342	X3862	33311221
X3655	32434422	X3683	34331321	X3711	12132344	X3739	42322342	X3801	24332334	X3863	24311212
X3656	22134431	X3684	13334244	X3712	11233222	X3740	13221234	X3802	42323323	X3864	31243234
X3657	12311334	X3685	44233242	X3713	42112442	X3741	34231311	X3803	42243331	X3865	34432123
X3658	23233243	X3686	31123211	X3714	22312312	X3742	42433422	X3804	11132444	X3866	31223344
X3659	31134312	X3687	42312112	X3715	22321312	X3743	23213322	X3805	42212432	X3867	44243221
X3660	32123124	X3688	21334421	X3716	21121243	X3744	31123121	X3806	42113212	X3868	44313311
X3661	32231311	X3689	42431231	X3717	11242343	X3745	33233211	X3807	31224224	X3869	34223231
X3662	23112313	X3690	13321244	X3718	24333324	X3746	34421323	X3808	21332223	X3870	13332123
X3663	12113242	X3691	33224424	X3719	43121221	X3747	32213331	X3809	44432111	X3871	32121333
X3664	42124333	X3692	13243221	X3720	23343443	X3748	34221224	X3810	22112134	X3872	44324324
X3665	32321344	X3693	43421321	X3721	42224321	X3749	23331242	X3811	31232342	X3873	43332223
X3666	13322342	X3694	13332442	X3722	24244332	X3750	42311232	X3812	12233432	X3874	11312432
X3667	33233112	X3695	23121322	X3723	23332113	X3751	32442331	X3813	42232331	X3875	13334424
X3668	23311134	X3696	12332133	X3724	21342431	X3752	31131342	X3814	24342311	X3876	31332134
X3669	13332431	X3697	21213443	X3725	34213432	X3753	31223432	X3815	32334232	X3877	33222312
X3670	43231223	X3698	24332431	X3726	31244321	X3754	13113324	X3816	42132431	X3878	12112232
X3671	34342321	X3699	31133234	X3727	24332442	X3755	42231231	X3817	44233213	X3879	42423133
X3672	13423331	X3700	42324331	X3728	32432231	X3756	12132211	X3818	34232442	X3880	33213312
X3673	22233442	X3701	42431233	X3729	24423342	X3757	23124433	X3819	13231123	X3881	42244433
X3674	23231113	X3702	42432322	X3730	42431244	X3758	33232432	X3820	23213421	X3882	24231244
X3675	13132134	X3703	13322324	X3731	22112233	X3759	43442423	X3821	11224433	X3883	23213443
X3676	42331113	X3704	24334422	X3732	32113132	X3760	34431113	X3822	33233244	X3884	44433222
X3677	44423234	X3705	23422111	X3733	22312444	X3761	24323323	X3823	21113233	X3885	34233124
X3678	11243243	X3706	24342313	X3734	11322243	X3762	32133442	X3824	44311243	X3886	44342324
X3679	21312423	X3707	32242443	X3735	11323421	X3763	22112244	X3825	34213344	X3887	12333112

X3764	23423231	X3826	42123123	X3888	21243422
X3765	12221332	X3827	13244431	X3889	34233423
X3766	11324434	X3828	42443122	X3890	42211134
X3767	12243433	X3829	31322331	X3891	13433132
X3768	24223311	X3830	33211233	X3892	22131133
X3769	12424331	X3831	13444231	X3893	13443344
X3770	33442134	X3832	11323424	X3894	42213321
X3771	23221321	X3833	22121323	X3895	21231324
X3772	42234432	X3834	31212232	X3896	11232331
X3773	12443442	X3835	22133131	X3897	24332123
X3774	44431233	X3836	32423444	X3898	12432213
X3775	32131332	X3837	33212434	X3899	24431233
X3776	22334332	X3838	21331222	X3900	31222213
X3777	22443232	X3839	22433224	X3901	31344234
X3778	42113313	X3840	24424213	X3902	12313123
X3779	22431332	X3841	33123134	X3903	12432311
X3780	43222331	X3842	44321213	X3904	44233312
X3781	32213344	X3843	23223231	X3905	43113123
X3782	34221123	X3844	21112324	X3906	42332134
X3783	32311321	X3845	11332444	X3907	43134212
X3784	13223313	X3846	12242331	X3908	44431242
X3785	42111331	X3847	24322434	X3909	42133124
X3786	42134224	X3848	22443124	X3910	42232234
X3787	42243124	X3849	11223243	X3911	32243244
X3788	11324324	X3850	24432423	X3912	33212234
X3789	32444333	X3851	42132442	X3913	32443222
X3790	21121124	X3852	34423312	X3914	12243123
X3791	44221113	X3853	32332243	X3915	13422123
X3792	23342431	X3854	31112323	X3916	12233344
X3793	34232431	X3855	24231233	X3917	24422433
X3794	21243131	X3856	32321131	X3918	13434232
X3795	23444324	X3857	32342332	X3919	24243243
X3796	43313224	X3858	44233112	X3920	13322243
X3797	32124323	X3859	22134332	X3921	24213332

# Big

or

# LITTLE

*From one item to one hundred,  
there is no minimum order.  
Every order is BIG to us!*



## STONE & BERG

Wholesale Locksmith Supply Company

(800) 225-7405 • Fax: (800) 535-5625

24hr. Toll-Free



# Infiniti X1-X7000

X3922	33444321	X3984	24231242	X4046	33443124	X4108	12213344	X4137	34334322	X4166	23124343
X3923	34211313	X3985	24213242	X4047	24213442	X4109	23421213	X4138	12221311	X4167	22132433
X3924	43243121	X3986	43342123	X4048	32213133	X4110	21322123	X4139	11234324	X4168	21312243
X3925	42433123	X3987	22211244	X4049	32134324	X4111	42312134	X4140	13213431	X4169	32111343
X3926	32342224	X3988	34432224	X4050	42244422	X4112	23132111	X4141	13431231	X4170	13213442
X3927	13232133	X3989	21331332	X4051	24431242	X4113	22442332	X4142	32234442	X4171	31321244
X3928	32342132	X3990	43132421	X4052	43312344	X4114	21322442	X4143	44421342	X4172	11343442
X3929	44333223	X3991	12113244	X4053	43232211	X4115	42133331	X4144	42423111	X4173	13311342
X3930	31331234	X3992	32243343	X4054	43421244	X4116	21322111	X4145	43422331	X4174	24342133
X3931	11234322	X3993	13431222	X4055	11331122	X4117	22233121	X4146	12212343	X4175	12421311
X3932	33342421	X3994	33132132	X4056	21311233	X4118	13233112	X4147	12344332	X4176	43223444
X3933	21132243	X3995	43243332	X4057	12311224	X4119	22444323	X4148	32342312	X4177	31342112
X3934	24431244	X3996	42312231	X4058	33312123	X4120	43221244	X4149	13442334	X4178	42213123
X3935	31322234	X3997	44224231	X4059	43342332	X4121	13213242	X4150	34312443	X4179	42423311
X3936	22334211	X3998	12233443	X4060	24324221	X4122	43124424	X4151	34421343	X4180	42421133
X3937	31113324	X3999	32121322	X4061	44224431	X4123	13323213	X4152	32223444	X4181	23123331
X3938	44233211	X4000	11312312	X4062	32321311	X4124	22111333	X4153	42223423	X4182	32211124
X3939	13312334	X4001	12133132	X4063	34424223	X4125	43342224	X4154	23244421	X4183	33423432
X3940	22231213	X4002	32213124	X4064	24343244	X4126	43212244	X4155	23334223	X4184	12334432
X3941	44432342	X4003	21223334	X4065	43132443	X4127	43431133	X4156	23442342	X4185	31122131
X3942	23234422	X4004	32122334	X4066	13213332	X4128	12333321	X4157	13112312	X4186	42432331
X3943	43132221	X4005	21124224	X4067	43344323	X4129	13242112	X4158	23342134	X4187	12422113
X3944	23331121	X4006	43334232	X4068	11243124	X4130	11344342	X4159	34221244	X4188	32432312
X3945	13342421	X4007	24213431	X4069	23224331	X4131	34231324	X4160	23311321	X4189	11213444
X3946	43234422	X4008	11312421	X4070	43243242	X4132	43342132	X4161	44334332	X4190	11133133
X3947	13233242	X4009	44231213	X4071	22123343	X4133	32423121	X4162	43122444	X4191	32242113
X3948	24432111	X4010	11322223	X4072	24323442	X4134	33121132	X4163	23313424	X4192	32123311
X3949	23442133	X4011	22213312	X4073	43111224	X4135	13123123	X4164	34332342	X4193	24211244
X3950	23121131	X4012	23423433	X4074	34213124	X4136	32311244	X4165	13323112	X4194	13122421
X3951	23343322	X4013	34213234	X4075	22434212						
X3952	23313422	X4014	24321121	X4076	32122132						
X3953	12422333	X4015	11233444	X4077	32243233						
X3954	33223122	X4016	12222443	X4078	12244344						
X3955	42224334	X4017	24433222	X4079	24432342						
X3956	42442134	X4018	43123133	X4080	21123344						
X3957	44311232	X4019	44233244	X4081	12232433						
X3958	12432422	X4020	11211343	X4082	32234233						
X3959	22342443	X4021	13324221	X4083	31232243						
X3960	33443232	X4022	31342324	X4084	42322344						
X3961	33212311	X4023	11312444	X4085	24312424						
X3962	11313212	X4024	31123321	X4086	21323313						
X3963	11312221	X4025	31124223	X4087	11132123						
X3964	33344423	X4026	32234211	X4088	12311123						
X3965	31112431	X4027	13423324	X4089	44213424						
X3966	32331312	X4028	21313213	X4090	12134312						
X3967	21331134	X4029	12422131	X4091	21243431						
X3968	42132132	X4030	32134434	X4092	31223243						
X3969	32422324	X4031	32321113	X4093	34322213						
X3970	32122323	X4032	21324343	X4094	13422444						
X3971	22344331	X4033	42344342	X4095	43324343						
X3972	32322123	X4034	42133232	X4096	34233434						
X3973	32431324	X4035	22324333	X4097	42242343						
X3974	12344312	X4036	22133122	X4098	13233213						
X3975	44423223	X4037	23343122	X4099	31123231						
X3976	12432433	X4038	12221123	X4100	43223224						
X3977	32322442	X4039	31132444	X4101	43123324						
X3978	22334233	X4040	23343243	X4102	43212233						
X3979	12213432	X4041	43321344	X4103	12443242						
X3980	13124234	X4042	24423434	X4104	42244334						
X3981	43422434	X4043	44213112	X4105	31234432						
X3982	22332213	X4044	44433231	X4106	34311334						
X3983	23443121	X4045	12343443	X4107	12332342						

## Highly Visible Widely Received



STI-6400

Our Exit Stopper® can help prevent unwanted exits and entries at any given time.

Can be set to your specifications as either an alarm or annunciator with a variety of exit modes. With all the features the Exit Stopper has to offer, you'll find a solution to help protect your emergency exit doors!

See our complete line of products.  
Call toll-free or visit our website

**800-888-4STI**  
**www.sti-usa.com**

*"We protect the things that protect you."*



**Safety Technology International, Inc.**  
2306 Airport Rd., Waterford, MI 48327  
Phone: 248-673-9898 • Fax: 248-673-1246

© 2004 STI

# Infiniti

## X1-X7000

X4195	34223323	X4257	43344224	X4319	11323244	X4381	11243231	X4443	32112122	X4505	12332423
X4196	23224423	X4258	43432231	X4320	13444222	X4382	32311222	X4444	32331132	X4506	32212444
X4197	31124243	X4259	11322121	X4321	12213124	X4383	34222243	X4445	34242212	X4507	24431134
X4198	31122133	X4260	43421323	X4322	13243342	X4384	23311213	X4446	13132224	X4508	33242132
X4199	22321132	X4261	13223432	X4323	24433334	X4385	32334434	X4447	23223424	X4509	31231134
X4200	12342334	X4262	12312342	X4324	33213231	X4386	23243213	X4448	23424313	X4510	34311123
X4201	13323312	X4263	23324422	X4325	34243312	X4387	43433232	X4449	11233431	X4511	13122344
X4202	12422423	X4264	12213234	X4326	44422134	X4388	12434334	X4450	33242343	X4512	33112312
X4203	44323213	X4265	43113422	X4327	24243331	X4389	31242343	X4451	43312331	X4513	31222134
X4204	33131223	X4266	43431113	X4328	34322422	X4390	11344421	X4452	21334212	X4514	24423133
X4205	42113122	X4267	43121324	X4329	44323211	X4391	24311342	X4453	21243312	X4515	13321224
X4206	23211124	X4268	42221113	X4330	43112122	X4392	24213321	X4454	11213424	X4516	21311334
X4207	44312334	X4269	12432112	X4331	24324432	X4393	22442244	X4455	13421234	X4517	32324321
X4208	43423442	X4270	34223422	X4332	12232334	X4394	23234244	X4456	34443242	X4518	33322443
X4209	32222434	X4271	22112123	X4333	33124344	X4395	21233324	X4457	32242131	X4519	44213233
X4210	32211133	X4272	42124443	X4334	12133224	X4396	32434211	X4458	34324244	X4520	24344313
X4211	44212434	X4273	31232311	X4335	43213232	X4397	31112213	X4459	44321312	X4521	13213321
X4212	12331222	X4274	43244212	X4336	34232312	X4398	34421321	X4460	31342443	X4522	21244423
X4213	13212243	X4275	42122423	X4337	43342312	X4399	31221113	X4461	32123113	X4523	32311134
X4214	44321334	X4276	34222434	X4338	44212311	X4400	43321113	X4462	31223331	X4524	24334431
X4215	42113311	X4277	43123111	X4339	23313312	X4401	11211233	X4463	42132242	X4525	12224331
X4216	22333221	X4278	42344421	X4340	34334223	X4402	32242333	X4464	32132113	X4526	22433112
X4217	13333212	X4279	44232131	X4341	13134433	X4403	13443324	X4465	34224221	X4527	12431211
X4218	23123313	X4280	33232234	X4342	42242244	X4404	42231332	X4466	43213212	X4528	42334233
X4219	32234242	X4281	32324431	X4343	12343243	X4405	13133423	X4467	43311233	X4529	11221213
X4220	33342212	X4282	11342313	X4344	12343122	X4406	11232133	X4468	33231121	X4530	24432311
X4221	23442111	X4283	42442323	X4345	31112444	X4407	31222231	X4469	32434431	X4531	24324333
X4222	24343121	X4284	44323312	X4346	23221323	X4408	23312322	X4470	34311224	X4532	43131222
X4223	22133421	X4285	43422311	X4347	34342134	X4409	34433131	X4471	43113424	X4533	11133434
X4224	13342212	X4286	44212234	X4348	13222244	X4410	33322221	X4472	34312221	X4534	43223332
X4225	32423343	X4287	24422123	X4349	44423423	X4411	23321322	X4473	34223424	X4535	23312423
X4226	22122133	X4288	24321134	X4350	21131132	X4412	31122443	X4474	21233423	X4536	11222332
X4227	43321131	X4289	44221234	X4351	11133423	X4413	44322324	X4475	24432234	X4537	23432444
X4228	12342112	X4290	42443223	X4352	44321231	X4414	24223234	X4476	43331224	X4538	33433242
X4229	13243122	X4291	13324432	X4353	31122113	X4415	43321311	X4477	13133223	X4539	22112334
X4230	22121343	X4292	13434423	X4354	12331231	X4416	43111233	X4478	23113334	X4540	33122113
X4231	33244321	X4293	13342124	X4355	23422344	X4417	43112333	X4479	32342433	X4541	31222442
X4232	22313344	X4294	43233212	X4356	44432234	X4418	13442123	X4480	42334211	X4542	22332321
X4233	23343423	X4295	31132123	X4357	34421224	X4419	31213334	X4481	13212212	X4543	13433242
X4234	33234223	X4296	43113433	X4358	21133422	X4420	12122311	X4482	22243331	X4544	12343423
X4235	11342432	X4297	31322434	X4359	32311323	X4421	12332344	X4483	24311311	X4545	23223213
X4236	44323112	X4298	31123123	X4360	23112443	X4422	21333442	X4484	33124331	X4546	32112333
X4237	13323211	X4299	11334244	X4361	11213421	X4423	44433123	X4485	42113322	X4547	32132322
X4238	33243223	X4300	43313112	X4362	44334233	X4424	42134213	X4486	23442344	X4548	11234423
X4239	32311242	X4301	34434431	X4363	42231132	X4425	44343312	X4487	24322124	X4549	31334442
X4240	43122123	X4302	24243124	X4364	43313442	X4426	12442331	X4488	22121321	X4550	34244311
X4241	22321332	X4303	23432244	X4365	21221244	X4427	32312324	X4489	42223311	X4551	42123323
X4242	31312421	X4304	23442333	X4366	22112444	X4428	21134421	X4490	32234332	X4552	42433431
X4243	42344223	X4305	42213334	X4367	24424231	X4429	21331123	X4491	33421243	X4553	23423334
X4244	33342344	X4306	31342121	X4368	23112322	X4430	32244212	X4492	22111344	X4554	32432211
X4245	22312332	X4307	32443442	X4369	24421133	X4431	33111331	X4493	23333442	X4555	21342242
X4246	34344222	X4308	32221323	X4370	34442212	X4432	32434233	X4494	42321121	X4556	12444311
X4247	44433422	X4309	32312223	X4371	11224332	X4433	21344433	X4495	12312234	X4557	21133424
X4248	43422122	X4310	22123134	X4372	21244331	X4434	13122322	X4496	34332344	X4558	23332434
X4249	32121131	X4311	23423132	X4373	33122131	X4435	13124342	X4497	12211124	X4559	11324243
X4250	31344232	X4312	42431134	X4374	24244321	X4436	22122443	X4498	21121333	X4560	23124424
X4251	32242342	X4313	44334211	X4375	24234223	X4437	22313243	X4499	22332121	X4561	21321324
X4252	23133134	X4314	11222442	X4376	13124432	X4438	42342421	X4500	43113211	X4562	21234422
X4253	31312444	X4315	32123131	X4377	44344313	X4439	32124442	X4501	12423323	X4563	34332423
X4254	33111234	X4316	23132432	X4378	43312122	X4440	24342111	X4502	11334424	X4564	43243222
X4255	12343322	X4317	33423131	X4379	33111223	X4441	22213231	X4503	31211321	X4565	13442132
X4256	44421331	X4318	12243334	X4380	13243234	X4442	44222211	X4504	23243211	X4566	42312123



# Infiniti X1-X7000

X4567	11222343	X4629	42223133	X4691	42423122
X4568	23442423	X4630	43243132	X4692	34422333
X4569	31133423	X4631	31322432	X4693	33211224
X4570	21231232	X4632	11224424	X4694	32423123
X4571	33324223	X4633	23421233	X4695	32442421
X4572	44311331	X4634	32443242	X4696	32334234
X4573	44423313	X4635	22333443	X4697	43122343
X4574	24433424	X4636	22313423	X4698	33221221
X4575	31121233	X4637	21342321	X4699	34223211
X4576	33422121	X4638	23313244	X4700	13342221
X4577	43213434	X4639	24333421	X4701	33112211
X4578	34223213	X4640	24324421	X4702	11232432
X4579	43322332	X4641	13343213	X4703	43342211
X4580	22124432	X4642	22111324	X4704	44234331
X4581	21343313	X4643	12132133	X4705	32231133
X4582	21213232	X4644	22124342	X4706	32221343
X4583	12233223	X4645	31242244	X4707	11122434
X4584	12433322	X4646	44324243	X4708	34242113
X4585	12112133	X4647	22444211	X4709	31134334
X4586	43431234	X4648	33122331	X4710	43344312
X4587	33113421	X4649	33424323	X4711	43221332
X4588	44233433	X4650	12243332	X4712	12243242
X4589	12442322	X4651	23223211	X4713	22442121
X4590	34232213	X4652	42323343	X4714	23244311
X4591	32242344	X4653	33232434	X4715	22313223
X4592	22332134	X4654	31311342	X4716	33243232
X4593	11122324	X4655	24312213	X4717	24333221
X4594	24443324	X4656	11222131	X4718	43312232
X4595	11231242	X4657	23243321	X4719	23121324
X4596	12124334	X4658	33113443	X4720	31231211
X4597	13133434	X4659	32242234	X4721	33321123
X4598	34322231	X4660	44333113	X4722	21244324
X4599	43211322	X4661	34212433	X4723	13242312
X4600	12443222	X4662	43122332	X4724	34212231
X4601	33432212	X4663	33134422	X4725	13234211
X4602	21344422	X4664	12224423	X4726	42342212
X4603	42343312	X4665	11221234	X4727	21133444
X4604	32331242	X4666	22234344	X4728	42213431
X4605	12312344	X4667	21233434	X4729	13224323
X4606	32422443	X4668	24433332	X4730	32231331
X4607	34433122	X4669	34324424	X4731	13232234
X4608	23311242	X4670	21123331	X4732	33321321
X4609	23421231	X4671	43131231	X4733	12112421
X4610	13324421	X4672	22131223	X4734	22443212
X4611	12231232	X4673	31212342	X4735	12421121
X4612	12112432	X4674	22233123	X4736	43231133
X4613	24322111	X4675	43342433	X4737	44333212
X4614	12324424	X4676	33123422	X4738	21223244
X4615	42312323	X4677	44224224	X4739	21122442
X4616	11331124	X4678	42334242	X4740	32433113
X4617	43322343	X4679	32322321	X4741	22311243
X4618	33243423	X4680	24213123	X4742	13311234
X4619	24332211	X4681	13112332	X4743	24442224
X4620	42332332	X4682	13433213	X4744	12434224
X4621	33422321	X4683	23134432	X4745	21344233
X4622	24422312	X4684	13234223	X4746	12344224
X4623	42232432	X4685	34433342	X4747	42312442
X4624	33231222	X4686	23113112	X4748	32134344
X4625	13421122	X4687	23443132	X4749	34433234
X4626	42122331	X4688	21133112	X4750	23442122
X4627	34324233	X4689	12222331	X4751	23332124
X4628	21121322	X4690	32132423	X4752	31324234

# SARGENT®

**For Great Prices and Service  
Call Today!**

## 10 Line Cylindrical Lever Locks



PART#	FUNCTIONS	LIST	LIST
		US3, US10, 26	US10B, 26D
28-10G04LL	Storeroom / Service with Guardbolt	328.00	319.00
28-10G05LL	Entrance / Office with Guardbolt	328.00	319.00
28-10U15LL	Passage	258.00	250.00
28-10G37LL	Classroom with Guardbolt	328.00	319.00
28-10U65LL	Privacy / Bathroom / Bedroom	295.00	286.00

## 8 Line Cylindrical Knob Locks



PART#	FUNCTIONS	LIST	LIST
		US10, 10B	US26D
28-8G04OB	Storeroom / Service with Guardbolt	357.00	351.00
28-8G05OB	Entrance / Office with Guardbolt	357.00	351.00
28-8U15OB	Passage	290.00	284.00
28-8G37OB	Classroom with Guardbolt	357.00	351.00
28-8U65OB	Privacy / Bathroom / Bedroom	326.00	320.00

## 6 Line Cylindrical Knob Locks



PART#	FUNCTIONS	LIST	LIST
		US26D	US3, 10, 10B
2428-6G04OB	Storeroom / Service with Guardbolt	135.00	139.00
2428-6G05OB	Entrance / Office with Guardbolt	135.00	139.00
2428-6U15OB	Passage	86.00	90.00
2428-6G37OB	Classroom with Guardbolt	135.00	139.00
2428-6U65OB	Privacy / Bathroom / Bedroom	100.00	104.00



**1-800-238-7541**  
**Call Today!**  
**For Great Prices  
and Service**

## Manufacturers & Distributors...

Interested in  
Mailing List Rental from  
*The National Locksmith®?*

Contact  
The Circulation Manager:  
**(630) 837-2044**

to learn how we  
can help you with  
your direct mail needs.



OID: 10/00

# Infiniti X1-X7000

X4753	34422131	X4815	22342331	X4877	43243334	X4939	43112324
X4754	22133322	X4816	33112242	X4878	43334234	X4940	43221224
X4755	31133434	X4817	42313122	X4879	32312432	X4941	21244221
X4756	22333122	X4818	23423424	X4880	33123424	X4942	43311334
X4757	23343311	X4819	31223324	X4881	42113232	X4943	22432131
X4758	42213442	X4820	43223134	X4882	13422112	X4944	44321132
X4759	21342422	X4821	44211231	X4883	33423124	X4945	22132431
X4760	23234431	X4822	44433312	X4884	31213442	X4946	34422423
X4761	42212234	X4823	43443431	X4885	22442431	X4947	24433312
X4762	12432431	X4824	43132234	X4886	42223111	X4948	23344433
X4763	42321134	X4825	23113332	X4887	32213432	X4949	21123133
X4764	34242342	X4826	13211312	X4888	42443313	X4950	13342234
X4765	31312332	X4827	22443443	X4889	32232112	X4951	31322124
X4766	22244334	X4828	23331132	X4890	44332233	X4952	23122321
X4767	12423431	X4829	43123122	X4891	22124421	X4953	34422234
X4768	24423221	X4830	43232433	X4892	31221234	X4954	13342423
X4769	42443232	X4831	34431322	X4893	23422243	X4955	32113444
X4770	32134234	X4832	31132312	X4894	23433423	X4956	32443244
X4771	22444312	X4833	42233233	X4895	44324322	X4957	42113423
X4772	42122311	X4834	34431133	X4896	11343321	X4958	33123224
X4773	11322443	X4835	21134434	X4897	24331221	X4959	33223124
X4774	23134223	X4836	32211122	X4898	23332432	X4960	22122333
X4775	24312321	X4837	23122213	X4899	23423332	X4961	21221332
X4776	24313223	X4838	13113234	X4900	11334321	X4962	33311243
X4777	33322344	X4839	34432244	X4901	34324213	X4963	34231212
X4778	24423111	X4840	42134424	X4902	21311224	X4964	24311234
X4779	42431123	X4841	42133221	X4903	23111244	X4965	31112244
X4780	42432212	X4842	12242443	X4904	44234232	X4966	32221321
X4781	22443111	X4843	21213434	X4905	43224432	X4967	42233242
X4782	24211332	X4844	13122122	X4906	11213233	X4968	42311311
X4783	42313113	X4845	42443124	X4907	23443323	X4969	13322443
X4784	33134242	X4846	32233421	X4908	43442432	X4970	33443111
X4785	22113221	X4847	34442221	X4909	22134224	X4971	21332421
X4786	44222433	X4848	21134324	X4910	13244334	X4972	32312221
X4787	31233213	X4849	22421133	X4911	42233332	X4973	43221123
X4788	42112242	X4850	32422111	X4912	23213212	X4974	11322322
X4789	21333312	X4851	32443312	X4913	33442433	X4975	24431123
X4790	32223134	X4852	13322221	X4914	43443332	X4976	34443222
X4791	34321322	X4853	34431221	X4915	33424433	X4977	31231123
X4792	12432442	X4854	31224424	X4916	44331212	X4978	13223331
X4793	21132432	X4855	34322132	X4917	44224433	X4979	13332231
X4794	21234312	X4856	31213431	X4918	23231212	X4980	13211123
X4795	12123423	X4857	13222433	X4919	33212113	X4981	13123433
X4796	12344321	X4858	42323112	X4920	33443212	X4982	22132442
X4797	13433211	X4859	13123323	X4921	31112233	X4983	22211132
X4798	21343212	X4860	44222233	X4922	34422113	X4984	44331344
X4799	22312112	X4861	33312242	X4923	23312313	X4985	44313344
X4800	13434234	X4862	32234231	X4924	22422134	X4986	12332243
X4801	33434234	X4863	21131321	X4925	44211312	X4987	34424313
X4802	11332233	X4864	43134443	X4926	12223442	X4988	12233133
X4803	42131322	X4865	43344332	X4927	13213334	X4989	11324342
X4804	42132112	X4866	22311232	X4928	22444332	X4990	12434424
X4805	43333112	X4867	13311223	X4929	24313421	X4991	24342122
X4806	42422321	X4868	12433423	X4930	12321324	X4992	42313421
X4807	21322321	X4869	13433244	X4931	13444323	X4993	24242113
X4808	13213123	X4870	43331211	X4932	22424312	X4994	12324332
X4809	24213334	X4871	33113223	X4933	13423421	X4995	31233244
X4810	12443433	X4872	43123432	X4934	24322421	X4996	44321332
X4811	13212443	X4873	31233312	X4935	11332242	X4997	42423432
X4812	11324322	X4874	13442242	X4936	13432421	X4998	32233234
X4813	13331124	X4875	42311342	X4937	32322112	X4999	23112311
X4814	23134211	X4876	31224312	X4938	33342234	X5000	31321224

## A NOTE FROM THE CIRCULATION MANAGER

I don't want **you** to be left out... but sometimes we do run out of back issues. Please be sure to send in your **Renewal Payment** on time and your **Change of Address** at least 4 weeks in advance. Then you won't be the one receiving a note saying, "Sorry, we ran out."

Send your name, old address and new address to:

The National Locksmith  
Address Change Dept.  
1533 Burgundy Pkwy.  
Streamwood, IL 60107.



# Infiniti X1-X7000

X5001	13432443	X5063	12333224	X5125	43211313	X5187	33324324
X5002	24313443	X5064	44422343	X5126	22312231	X5188	12243233
X5003	13122211	X5065	32134322	X5127	31232443	X5189	21331231
X5004	21133233	X5066	31332321	X5128	42432421	X5190	23132434
X5005	21243213	X5067	12433434	X5129	33344432	X5191	32332113
X5006	24234324	X5068	33123312	X5130	23224344	X5192	43433221
X5007	31231321	X5069	12424432	X5131	13322122	X5193	42342221
X5008	33244233	X5070	31211323	X5132	44213433	X5194	24331342
X5009	22322434	X5071	32112324	X5133	34211333	X5195	42433233
X5010	31344311	X5072	32224443	X5134	13344432	X5196	31134211
X5011	44232331	X5073	42431242	X5135	11244431	X5197	43122112
X5012	42231233	X5074	24322333	X5136	11132433	X5198	13423342
X5013	31212344	X5075	12334311	X5137	42433134	X5199	24313342
X5014	44334222	X5076	32442131	X5138	24223133	X5200	33233442
X5015	24332231	X5077	43113242	X5139	32442322	X5201	43224421
X5016	23111242	X5078	12343311	X5140	33224343	X5202	22312134
X5017	23223343	X5079	12244313	X5141	32242243	X5203	11232234
X5018	31113234	X5080	44324342	X5142	44432232	X5204	21331233
X5019	12342343	X5081	24224312	X5143	11332422	X5205	21221123
X5020	42312343	X5082	32221132	X5144	23423112	X5206	33431222
X5021	23321223	X5083	43422421	X5145	42231242	X5207	32334421
X5022	12421134	X5084	31224343	X5146	24442321	X5208	21322233
X5023	21123324	X5085	13421333	X5147	33434232	X5209	43242432
X5024	43321223	X5086	32224333	X5148	32113213	X5210	22332444
X5025	44422332	X5087	22421344	X5149	21133242	X5211	44332422
X5026	21332443	X5088	32442133	X5150	23111222	X5212	13322344
X5027	32232231	X5089	43332443	X5151	24244233	X5213	43332131
X5028	31331342	X5090	43432211	X5152	22324434	X5214	33122243
X5029	23312243	X5091	33311232	X5153	22133232	X5215	24433121
X5030	32122121	X5092	24311223	X5154	13224422	X5216	24312244
X5031	13313324	X5093	23433434	X5155	31324443	X5217	24243111
X5032	31123323	X5094	43133422	X5156	42211334	X5218	24221344
X5033	32132331	X5095	42332321	X5157	32422342	X5219	23431243
X5034	43332421	X5096	44213422	X5158	43123234	X5220	32311213
X5035	44243313	X5097	32344222	X5159	43232134	X5221	21331244
X5036	11322344	X5098	23344213	X5160	13134442	X5222	42113133
X5037	33423322	X5099	22211213	X5161	31232212	X5223	24342324
X5038	34223343	X5100	33221131	X5162	32324433	X5224	34331211
X5039	42231244	X5101	32434222	X5163	22244244	X5225	12132421
X5040	44332242	X5102	44211123	X5164	13322322	X5226	33124423
X5041	12421332	X5103	42442433	X5165	34221134	X5227	12423121
X5042	31122243	X5104	34442234	X5166	11332433	X5228	23333242
X5043	43113343	X5105	11132422	X5167	22324324	X5229	21112234
X5044	42322443	X5106	12223312	X5168	44311311	X5230	31134233
X5045	23312311	X5107	44433121	X5169	22234324	X5231	33224211
X5046	23211322	X5108	11333443	X5170	33324434	X5232	33342223
X5047	11212231	X5109	32444311	X5171	34312324	X5233	23344233
X5048	11122432	X5110	23344422	X5172	42243322	X5234	24422112
X5049	34332243	X5111	23221132	X5173	42432443	X5235	22433442
X5050	23133132	X5112	23342233	X5174	34212312	X5236	11211224
X5051	34312223	X5113	33442442	X5175	31213244	X5237	12422133
X5052	12243244	X5114	34211221	X5176	34242234	X5238	13342223
X5053	34324332	X5115	23112232	X5177	12444223	X5239	42313342
X5054	42213244	X5116	12113334	X5178	32213234	X5240	44332433
X5055	42313443	X5117	13342113	X5179	42333443	X5241	13113331
X5056	42332121	X5118	13232434	X5180	24211132	X5242	13331131
X5057	21342233	X5119	11331331	X5181	42334222	X5243	23244344
X5058	24224424	X5120	11244222	X5182	42324443	X5244	43313222
X5059	32212343	X5121	24312433	X5183	44313243	X5245	42234243
X5060	24424224	X5122	23131134	X5184	13421124	X5246	31131322
X5061	34322312	X5123	32443233	X5185	44342331	X5247	24224343
X5062	33312422	X5124	32134232	X5186	24312233	X5248	22331234

**MORNING INDUSTRY INC.**  
www.morningindustry.com  
800-355-0157 909-869-5663 fax

## KEYLESS HOME ACCESS LOCKS

**ELECTRONIC TOUCHPAD**

**PAKL-01RP** Lever Entry

**PKF-01P** Deadbolt

**PAKK-01P** Knob Entry

**REMOTE CONTROL**

**AKL-01RP** Lever Entry

**KF01P** Deadbolt

**AKK-01P** Knob Entry

**MECHANICAL PUSH BUTTON**

**MP-500** w/Grade 1 2-3/4 Latch

**MP-370** Knob

Circle 259 on Rapid Reply

### Bonding Information!!

**You are invited** to purchase a \$15,000 Bond Certificate and Bond Card along with your subscription. For a \$17.00 charge you will receive a Certificate and Card personalized with your name.

**Previously**, we could only Bond the individual subscribing to *The National Locksmith*. Now, however, we are able to Bond any of your employees as well as you, the actual subscriber. These additional personalized Bonds are available at \$25.00 each.

**If you already have a Bond**, you will receive notice to renew your bond. You will receive this notice in the mail several months before your Bond expires.

**New subscribers:** To receive a Bond, please follow the instructions below.

**To order bonds**, send a sheet with your name, address, city, state, zip and phone number (or that of the person to receive the bond), **include a check or money order** for the appropriate amount, and mail to: **The National Locksmith**  
P.O. Box 77-79592  
Chicago, IL 60678-7592.

01D-4/02

# Infiniti

## X1-X7000

X5249	32233344	X5311	23432132	X5373	42312242	X5435	11243121	X5497	13431242	X5559	13422424
X5250	33424431	X5312	13223324	X5374	44231224	X5436	34431311	X5498	44324423	X5560	23243224
X5251	32342431	X5313	21312211	X5375	43323223	X5437	33312442	X5499	24211242	X5561	42122133
X5252	32321322	X5314	42334231	X5376	13222444	X5438	22132233	X5500	44232133	X5562	21113444
X5253	33221113	X5315	24442211	X5377	22432324	X5439	42342234	X5501	33434423	X5563	22244343
X5254	32124321	X5316	44223423	X5378	32133422	X5440	33123112	X5502	13232232	X5564	42121343
X5255	32424434	X5317	43311224	X5379	42344333	X5441	43342431	X5503	44331113	X5565	43124244
X5256	42312211	X5318	12431232	X5380	42113113	X5442	44312321	X5504	42442231	X5566	22444321
X5257	11234443	X5319	43124323	X5381	11323323	X5443	44313223	X5505	33443423	X5567	13444312
X5258	21243321	X5320	33442323	X5382	33442112	X5444	42342423	X5506	43344321	X5568	12224344
X5259	21343342	X5321	31344313	X5383	24223111	X5445	21131222	X5507	33123442	X5569	13122313
X5260	33213444	X5322	22443423	X5384	23121221	X5446	31121123	X5508	21132342	X5570	11232434
X5261	44242211	X5323	24331234	X5385	12233212	X5447	13331122	X5509	22443331	X5571	44321233
X5262	43123342	X5324	22133111	X5386	12232244	X5448	43323322	X5510	22123312	X5572	33132231
X5263	42131331	X5325	24334224	X5387	34222133	X5449	43133444	X5511	42313322	X5573	12331233
X5264	12312232	X5326	23111334	X5388	12434213	X5450	43123223	X5512	12443312	X5574	34342213
X5265	32231324	X5327	24233233	X5389	24334433	X5451	24424323	X5513	21224443	X5575	22234423
X5266	21334342	X5328	21343113	X5390	23342213	X5452	43222333	X5514	33212342	X5576	33243113
X5267	33234423	X5329	22344322	X5391	34344211	X5453	24223434	X5515	22434324	X5577	13123233
X5268	33134222	X5330	33113324	X5392	43334421	X5454	22343343	X5516	32134331	X5578	11321334
X5269	32132232	X5331	33442231	X5393	44233442	X5455	13444211	X5517	21331121	X5579	43212112
X5270	32232132	X5332	12112342	X5394	22213444	X5456	13424332	X5518	13332424	X5580	24433422
X5271	31331124	X5333	23122231	X5395	34442223	X5457	44224332	X5519	22344324	X5581	21131231
X5272	34312434	X5334	32443433	X5396	13431244	X5458	34224223	X5520	24213244	X5582	42344234
X5273	23113321	X5335	44312213	X5397	21231344	X5459	31342322	X5521	34222113	X5583	44322342
X5274	23122433	X5336	31132433	X5398	32131134	X5460	21313323	X5522	21344231	X5584	11331213
X5275	21311332	X5337	22334242	X5399	34324231	X5461	42422134	X5523	31344344	X5585	31344243
X5276	34431234	X5338	22123424	X5400	12221134	X5462	32222113	X5524	21224333	X5586	11133344
X5277	13132244	X5339	23113231	X5401	43223334	X5463	24233242	X5525	33224442	X5587	32133424
X5278	32442342	X5340	32434433	X5402	43443211	X5464	32332324	X5526	12134342	X5588	13242213
X5279	23344431	X5341	33431231	X5403	13323444	X5465	13112433	X5527	33213424	X5589	33223131
X5280	24211213	X5342	22134442	X5404	23312133	X5466	21334243	X5528	23131224	X5590	43232431
X5281	43133424	X5343	21332234	X5405	42343321	X5467	13432113	X5529	13422431	X5591	11342311
X5282	33222334	X5344	42242132	X5406	43332234	X5468	21313444	X5530	23211313	X5592	24221311
X5283	31244231	X5345	33231132	X5407	43244331	X5469	22311331	X5531	32344334	X5593	42223421
X5284	34431331	X5346	34233421	X5408	43133112	X5470	22211321	X5532	44222431	X5594	31113434
X5285	23312212	X5347	21332122	X5409	31132233	X5471	34434233	X5533	23322213	X5595	43243244
X5286	44212113	X5348	31311212	X5410	21223132	X5472	12134432	X5534	21134344	X5596	33122133
X5287	43443213	X5349	13221344	X5411	43332122	X5473	12112434	X5535	43244423	X5597	21323324
X5288	21112322	X5350	43431221	X5412	13322223	X5474	32124334	X5536	31243243	X5598	43234244
X5289	13244244	X5351	43311123	X5413	13342243	X5475	13233244	X5537	23422432	X5599	22432243
X5290	44431321	X5352	44421243	X5414	24233332	X5476	21323243	X5538	42122131	X5600	43343322
X5291	34342233	X5353	44331133	X5415	43224322	X5477	11344333	X5539	11223443	X5601	44422422
X5292	33422134	X5354	13442233	X5416	33134231	X5478	24423243	X5540	34224443	X5602	34433124
X5293	12132443	X5355	23133224	X5417	34234224	X5479	43324422	X5541	21332342	X5603	22442312
X5294	42333122	X5356	13313212	X5418	21124332	X5480	11222134	X5542	43312113	X5604	21224243
X5295	21342134	X5357	12442421	X5419	11324423	X5481	34233234	X5543	34442243	X5605	24421221
X5296	31331322	X5358	31232344	X5420	31113331	X5482	34211344	X5544	23331213	X5606	11324311
X5297	31122223	X5359	44313423	X5421	31243211	X5483	11213433	X5545	31234243	X5607	13324434
X5298	13242233	X5360	12424421	X5422	13113434	X5484	33213112	X5546	21323342	X5608	12134211
X5299	24423122	X5361	42331221	X5423	24431321	X5485	23332111	X5547	32244331	X5609	34312432
X5300	32232444	X5362	43134423	X5424	21223321	X5486	13443122	X5548	42312422	X5610	23313123
X5301	32222131	X5363	44213224	X5425	11243322	X5487	42111342	X5549	42311212	X5611	24233213
X5302	44333243	X5364	13431233	X5426	34434211	X5488	42232434	X5550	11344223	X5612	43224324
X5303	12242113	X5365	44322423	X5427	13232432	X5489	43442212	X5551	42442112	X5613	12331244
X5304	31132422	X5366	24433231	X5428	21324422	X5490	13423434	X5552	31334321	X5614	43312443
X5305	23123432	X5367	13221211	X5429	22243311	X5491	22233424	X5553	24332424	X5615	23443431
X5306	23233122	X5368	34321223	X5430	12113332	X5492	44333423	X5554	43121331	X5616	13112132
X5307	12211322	X5369	12242342	X5431	23423233	X5493	32132124	X5555	11331243	X5617	42322131
X5308	31342331	X5370	23312124	X5432	12231344	X5494	33342124	X5556	21134234	X5618	12232134
X5309	22432434	X5371	34222131	X5433	43121342	X5495	43112113	X5557	23131123	X5619	11212333
X5310	33243443	X5372	32223334	X5434	13313311	X5496	32113222	X5558	42443342	X5620	24432344



# Infiniti X1-X7000

X5621	34423213	X5667	13213244	X5713	32244423	X5759	12132223	X5805	12443233	X5851	43443422
X5622	13422323	X5668	21342334	X5714	24234344	X5760	11213224	X5806	42233334	X5852	23221213
X5623	43122431	X5669	13344331	X5715	32444223	X5761	44242134	X5807	44312433	X5853	21124313
X5624	43232442	X5670	22213424	X5716	23123342	X5762	13321323	X5808	33113434	X5854	34432132
X5625	22213112	X5671	13424233	X5717	44243342	X5763	23132212	X5809	31223443	X5855	32131224
X5626	23311312	X5672	22312123	X5718	32133112	X5764	33221234	X5810	42122443	X5856	33123132
X5627	44243122	X5673	32432444	X5719	23334432	X5765	33223113	X5811	33244231	X5857	32232211
X5628	44433134	X5674	22343242	X5720	42333344	X5766	42342223	X5812	42213231	X5858	23432433
X5629	11234331	X5675	42234342	X5721	31233111	X5767	43243233	X5813	24231213	X5859	44322243
X5630	42421344	X5676	21132434	X5722	23443332	X5768	44423331	X5814	11133243	X5860	13332132
X5631	31312231	X5677	23123133	X5723	44431213	X5769	11212431	X5815	12423123	X5861	31133223
X5632	32112113	X5678	13133122	X5724	43311332	X5770	12442133	X5816	44232432	X5862	33243344
X5633	43234433	X5679	21342131	X5725	12422443	X5771	31123233	X5817	21123432	X5863	21134322
X5634	23234433	X5680	12112223	X5726	44334242	X5772	33113311	X5818	42331234	X5864	42131232
X5635	34211324	X5681	13242433	X5727	33132424	X5773	34432332	X5819	23112133	X5865	21321331
X5636	12443244	X5682	24243322	X5728	13244343	X5774	43244324	X5820	11223324	X5866	42131122
X5637	43321322	X5683	21323124	X5729	12331242	X5775	21113213	X5821	13134212	X5867	13133243
X5638	22131342	X5684	24443122	X5730	23433131	X5776	44311212	X5822	43233232	X5868	43213243
X5639	13222431	X5685	21323423	X5731	44222132	X5777	21313424	X5823	21112313	X5869	33124223
X5640	13422231	X5686	42423124	X5732	42122113	X5778	31244222	X5824	12334234	X5870	22233134
X5641	23424331	X5687	43243343	X5733	11321231	X5779	23342112	X5825	23423422	X5871	13133421
X5642	21324323	X5688	33132134	X5734	33444224	X5780	32133444	X5826	32432224	X5872	42233433
X5643	22422343	X5689	33423113	X5735	13342232	X5781	32312434	X5827	34322121	X5873	13242442
X5644	11311342	X5690	42132424	X5736	31112334	X5782	42332444	X5828	42131324	X5874	43133242
X5645	24324434	X5691	21233124	X5737	43124233	X5783	13331243	X5829	23122444	X5875	33223221
X5646	43122424	X5692	43343243	X5738	31131331	X5784	11122342	X5830	42313124	X5876	32113123
X5647	11331324	X5693	11323442	X5739	31331131	X5785	12112124	X5831	42124322	X5877	32131123
X5648	33233121	X5694	32423312	X5740	23342334	X5786	11223342	X5832	11342324	X5878	24332224
X5649	24233112	X5695	32123423	X5741	11212443	X5787	23432213	X5833	13344322	X5879	42431121
X5650	12444232	X5696	23343421	X5742	31332444	X5788	31112224	X5834	31133344	X5880	42442431
X5651	22432432	X5697	32432123	X5743	32431243	X5789	34442311	X5835	24421344	X5881	34442232
X5652	44234311	X5698	34212332	X5744	21321342	X5790	42212113	X5836	13334242	X5882	42112211
X5653	12311332	X5699	42112312	X5745	34312421	X5791	42322113	X5837	33122443	X5883	12233322
X5654	13422334	X5700	21122244	X5746	21244322	X5792	44234234	X5838	21234334	X5884	43111343
X5655	22423432	X5701	32242133	X5747	34423211	X5793	24334312	X5839	23432422	X5885	13422224
X5656	31242132	X5702	23324323	X5748	12133433	X5794	23243442	X5840	44322122	X5886	24332132
X5657	23243323	X5703	12433131	X5749	13424312	X5795	23124323	X5841	23112432	X5887	12132324
X5658	42432113	X5704	13312424	X5750	44224312	X5796	44231211	X5842	24323343	X5888	32442122
X5659	13112424	X5705	44324311	X5751	32122134	X5797	24433123	X5843	23421132	X5889	23121342
X5660	42244224	X5706	43324323	X5752	23123324	X5798	44243234	X5844	13343224	X5890	24312431
X5661	21313421	X5707	42442121	X5753	21312342	X5799	23332221	X5845	11234232	X5891	12433122
X5662	43423224	X5708	13123343	X5754	21132122	X5800	11122312	X5846	42121321	X5892	42123433
X5663	34442313	X5709	42243223	X5755	12223123	X5801	22423131	X5847	12211313	X5893	43343423
X5664	44223311	X5710	32433232	X5756	22133432	X5802	12242234	X5848	44233121	X5894	34423134
X5665	44211343	X5711	13221223	X5757	21123122	X5803	12133222	X5849	21321133	X5895	31134222
X5666	21244432	X5712	12344242	X5758	43423323	X5804	24343312	X5850	13332224	X5896	11343323

LSI

## TRAINING AT ITS BEST.

Professional Industrial Locksmithing  
LSI 150 4 Credit Hours Nov 29 - Dec 10

GSA: Inspector & Technician Certification  
LSI 130 4 Credit Hours July 26 - Aug 6

Fundamentals of Electricity  
LSI 160 2 Credit Hours Oct 11 - 15

Access Control  
LSI 170 2 Credit Hours Oct 18 - 22

**COLLEGE ACCREDITED COURSES**



800.654.0637  
lsi-lockmasters.com  
education@lockmasters.com

# Infiniti X1-X7000

X5897	22124434	X5926	21223433	X5955	22133221	X5984	42243311	X6046	24323112	X6108	44213134
X5898	34334432	X5927	31213231	X5956	13212313	X5985	44331232	X6047	33124243	X6109	12321342
X5899	22344212	X5928	42124432	X5957	43333224	X5986	23231232	X6048	22343112	X6110	42243133
X5900	23122123	X5929	13134224	X5958	13443223	X5987	21132311	X6049	42313313	X6111	12444313
X5901	34443312	X5930	31331311	X5959	32234424	X5988	13423133	X6050	12433234	X6112	32231212
X5902	42343442	X5931	31331122	X5960	13343211	X5989	24334213	X6051	12234224	X6113	11122344
X5903	44212342	X5932	31243124	X5961	33324243	X5990	22123442	X6052	22331221	X6114	44423324
X5904	11132431	X5933	42234421	X5962	44312424	X5991	43244221	X6053	23344231	X6115	34244313
X5905	33342221	X5934	11132442	X5963	23323344	X5992	43231232	X6054	24312224	X6116	42323444
X5906	43131233	X5935	42211332	X5964	33312211	X5993	23213232	X6055	44211233	X6117	24223421
X5907	12113321	X5936	42344232	X5965	31122221	X5994	32334212	X6056	43131242	X6118	24323211
X5908	34433111	X5937	22133443	X5966	21342111	X5995	31234342	X6057	23324211	X6119	42244343
X5909	12331121	X5938	24244231	X5967	12442342	X5996	42124342	X6058	11344232	X6120	23111332
X5910	21223111	X5939	43131244	X5968	34222342	X5997	33234443	X6059	43324211	X6121	42323312
X5911	22123112	X5940	21244223	X5969	12233243	X5998	11244433	X6060	12233342	X6122	23311132
X5912	42433132	X5941	13211233	X5970	12433342	X5999	24323213	X6061	22233321	X6123	23431124
X5913	22132112	X5942	23123111	X5971	12113231	X6000	24422323	X6062	22211323	X6124	42213323
X5914	32244324	X5943	44431121	X5972	21312234	X6001	11122234	X6063	32431122	X6125	33424321
X5915	23433122	X5944	32231232	X5973	34213342	X6002	21324211	X6064	44333324	X6126	23333422
X5916	42132332	X5945	13212434	X5974	31124333	X6003	32424333	X6065	24312132	X6127	12442333
X5917	22131322	X5946	24313113	X5975	33431134	X6004	33422332	X6066	32134212	X6128	22121123
X5918	33212232	X5947	24422424	X5976	43234431	X6005	22334231	X6067	12122134	X6129	21213243
X5919	21313242	X5948	22433332	X5977	31243112	X6006	34422133	X6068	34234213	X6130	22312343
X5920	21134232	X5949	24434232	X5978	13431134	X6007	11232232	X6069	32124422	X6131	44322223
X5921	13211231	X5950	32422124	X5979	33231231	X6008	24321334	X6070	23322231	X6132	22213233
X5922	22313122	X5951	31243331	X5980	43213324	X6009	31223342	X6071	11224343	X6133	12212213
X5923	24422431	X5952	32324424	X5981	33112132	X6010	44432131	X6072	13212311	X6134	12312113
X5924	42342243	X5953	23112421	X5982	24313122	X6011	12343421	X6073	43221121	X6135	31132431
X5925	34342334	X5954	34342112	X5983	43124442	X6012	12434321	X6074	23433234	X6136	34423231
						X6013	23134434	X6075	12232431	X6137	21332232
						X6014	22343244	X6076	24431121	X6138	24234443
						X6015	43132113	X6077	23122431	X6139	34242333
						X6016	23444212	X6078	24424431	X6140	21113222
						X6017	43121234	X6079	24323312	X6141	32244221
						X6018	43212134	X6080	13243243	X6142	33442332
						X6019	33433211	X6081	34243213	X6143	34434222
						X6020	24422231	X6082	22311311	X6144	43231212
						X6021	44344331	X6083	32322343	X6145	13321343
						X6022	42342124	X6084	34213423	X6146	22133342
						X6023	42421311	X6085	34311332	X6147	31122333
						X6024	24234322	X6086	42244323	X6148	43223244
						X6025	23121331	X6087	21123234	X6149	13231121
						X6026	42124324	X6088	24332312	X6150	11243132
						X6027	13344324	X6089	12432233	X6151	43232244
						X6028	33112424	X6090	33433244	X6152	42222334
						X6029	34231232	X6091	43222434	X6153	33211334
						X6030	43423431	X6092	11334332	X6154	23432112
						X6031	31133243	X6093	43422234	X6155	24443223
						X6032	31133421	X6094	33434212	X6156	11244422
						X6033	32233113	X6095	32342242	X6157	43134243
						X6034	32213423	X6096	13434212	X6158	13222233
						X6035	33422343	X6097	33211134	X6159	22313443
						X6036	32431223	X6098	34212242	X6160	33432421
						X6037	24422334	X6099	23122424	X6161	33122221
						X6038	13443342	X6100	34324224	X6162	23311211
						X6039	23124244	X6101	34221121	X6163	33111342
						X6040	33231244	X6102	12232442	X6164	31132442
						X6041	21333231	X6103	13421211	X6165	32332212
						X6042	44324313	X6104	33321134	X6166	12334232
						X6043	12442111	X6105	33232113	X6167	12312122
						X6044	24423311	X6106	23443213	X6168	34424331
						X6045	21112232	X6107	43313213	X6169	34443233



**Locks For All  
Coin Operated  
Equipment  
And  
Trailer Locks  
And  
Commercial Truck Locks**

*Serving The Locksmith  
with  
Cam Locks - Screw Locks - Plug Locks*

**T Handles • T Handle Locks  
Pad Locks • Laundry Coin Boxes  
Car Wash Vaults • King Pin Locks  
Draw Bar Hitch Locks**

**Factory Center For:  
Medeco • Abloy • Compx/Fort  
Compx/Chicago • Compx/National  
Abus • S & G**

**RA-LOCK COMPANY**  
**888-256-3478**  
www.ralock.com  
**See Us At BOOTH 143**



# Infiniti X1-X7000

X6170	33342423	X6232	11323343	X6294	11334233	X6356	34432422	X6385	42132321	X6414	21333242
X6171	22443133	X6233	32332124	X6295	13223443	X6357	23122343	X6386	42221344	X6415	13324243
X6172	12123322	X6234	31321323	X6296	32342422	X6358	24333443	X6387	13321123	X6416	42233312
X6173	32342321	X6235	32121324	X6297	24233334	X6359	32434312	X6388	33324342	X6417	33113234
X6174	13442343	X6236	32344211	X6298	24213231	X6360	22423124	X6389	12124422	X6418	42113421
X6175	12423444	X6237	31312323	X6299	23243134	X6361	31123433	X6390	22323321	X6419	11132233
X6176	42422332	X6238	23213434	X6300	22234443	X6362	43342321	X6391	21133431	X6420	32331213
X6177	24442334	X6239	32132111	X6301	34432213	X6363	11212243	X6392	23234233	X6421	23213324
X6178	23124233	X6240	13423221	X6302	12442344	X6364	32344343	X6393	22344221	X6422	32421343
X6179	33222112	X6241	42124421	X6303	23223442	X6365	42233112	X6394	42132211	X6423	21331132
X6180	43334212	X6242	31234421	X6304	12422324	X6366	33222244	X6395	13344212	X6424	43343311
X6181	21322332	X6243	31213323	X6305	22132132	X6367	12233331	X6396	42212342	X6425	22442321
X6182	32133242	X6244	31331243	X6306	42442332	X6368	11313344	X6397	31334424	X6426	13231231
X6183	22432133	X6245	24312312	X6307	44223234	X6369	22313342	X6398	43213311	X6427	13122423
X6184	42223434	X6246	11243311	X6308	43211333	X6370	31233442	X6399	21123223	X6428	31224211
X6185	11242211	X6247	13423111	X6309	43322224	X6371	32332432	X6400	21332133	X6429	33132211
X6186	21243224	X6248	11334211	X6310	22123132	X6372	11321332	X6401	22333344	X6430	34322323
X6187	11224211	X6249	21313244	X6311	33342113	X6373	32432332	X6402	33223344	X6431	43223112
X6188	34322433	X6250	23343124	X6312	44232234	X6374	44334231	X6403	43112322	X6432	42113243
X6189	43332232	X6251	24211323	X6313	42234434	X6375	33243324	X6404	32223112	X6433	13224334
X6190	32444232	X6252	33112332	X6314	42443423	X6376	42322313	X6405	44233123	X6434	43222432
X6191	31334244	X6253	22133124	X6315	23333424	X6377	32233432	X6406	43232213	X6435	32111244
X6192	32233311	X6254	12123421	X6316	24434423	X6378	22111234	X6407	32321313	X6436	33442244
X6193	34243211	X6255	21234433	X6317	33322131	X6379	34423433	X6408	23243121	X6437	23124442
X6194	43222243	X6256	12432121	X6318	34242344	X6380	12442423	X6409	13312321	X6438	13213231
X6195	34242131	X6257	24321312	X6319	31131122	X6381	31312442	X6410	42121323	X6439	24231312
X6196	44432122	X6258	44243243	X6320	31131232	X6382	24233433	X6411	32312313	X6440	12333123
X6197	34211243	X6259	11244211	X6321	23122332	X6383	34432433	X6412	11312343	X6441	13421223
X6198	21123342	X6260	43242331	X6322	34211232	X6384	12424434	X6413	24433431	X6442	42131124
X6199	33324322	X6261	13432223	X6323	23322132						
X6200	42422343	X6262	44221223	X6324	13334222						
X6201	12313224	X6263	34433421	X6325	11321132						
X6202	21322343	X6264	23244313	X6326	24432122						
X6203	12321133	X6265	23243112	X6327	42233213						
X6204	33432443	X6266	32113433	X6328	12334421						
X6205	34242133	X6267	24324223	X6329	43322132						
X6206	33423443	X6268	12431342	X6330	42423131						
X6207	42224433	X6269	11342443	X6331	13132444						
X6208	12323322	X6270	21333424	X6332	23343223						
X6209	42334422	X6271	12422342	X6333	21321243						
X6210	24334442	X6272	44433431	X6334	12443134						
X6211	24443342	X6273	13212432	X6335	12213423						
X6212	11311234	X6274	31131324	X6336	34223442						
X6213	42112332	X6275	31132132	X6337	11311223						
X6214	13421324	X6276	23113323	X6338	12443321						
X6215	43313211	X6277	34442124	X6339	32421132						
X6216	43432123	X6278	12433331	X6340	34243321						
X6217	43132423	X6279	32321324	X6341	43432224						
X6218	43224311	X6280	43342242	X6342	22342342						
X6219	32211322	X6281	44212232	X6343	12243343						
X6220	22323123	X6282	34434231	X6344	21134331						
X6221	12213342	X6283	33223432	X6345	43233131						
X6222	24243223	X6284	33422244	X6346	23233131						
X6223	43224434	X6285	12443112	X6347	33424334						
X6224	43442234	X6286	13231222	X6348	43112234						
X6225	34432321	X6287	23132131	X6349	43221134						
X6226	21234244	X6288	44311342	X6350	12432134						
X6227	21213324	X6289	12231234	X6351	23221231						
X6228	13324223	X6290	33311311	X6352	21334423						
X6229	32113422	X6291	43211221	X6353	13422213						
X6230	12321331	X6292	13312213	X6354	22324342						
X6231	42342232	X6293	42134244	X6355	22331342						

## SAFE MOVING.

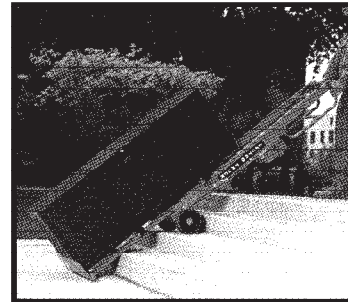

One person can safely lift, control, climb up and down stairs and move loads up to 1500 pounds with this motorized material handling device.

Replace manpower with mechanized power and reduce fatigue and the injuries associated with it. Increase productivity and eliminate product and property damage by using a Lectro Truck.

Call 1-800-619-0625 or write for more information.

Lectro Truck can be used as a:  
Power stair climber • Power dock leveler  
Power lift gate • Power warehouse dolly

**Lectro Truck™**  
STAIR CLIMBING SYSTEM

INNOVATIVE MOVING SYSTEMS  
310 S. 10th Street, P.O. Box 700169 • Oostburg, WI 53070  
Phone: 1-920-564-6272 • Fax: 1-920-564-2322  
<http://www.lectrotruck.com> • e-mail: [lectro@excel.net](mailto:lectro@excel.net)

# Infiniti

## X1-X7000

X6443	22443221	X6505	23333444	X6567	44342322	X6629	44422123	X6691	42344311	X6753	11322113
X6444	42113124	X6506	22112442	X6568	42133113	X6630	44243124	X6692	13112213	X6754	13312433
X6445	43344242	X6507	33423234	X6569	42433242	X6631	22124344	X6693	24342322	X6755	21333244
X6446	13443232	X6508	21323113	X6570	12343124	X6632	23432431	X6694	24313322	X6756	13213323
X6447	24324243	X6509	24243311	X6571	32233443	X6633	11322431	X6695	12244331	X6757	32211313
X6448	21122323	X6510	24234331	X6572	22111331	X6634	23434422	X6696	24443124	X6758	12223431
X6449	33431123	X6511	31134422	X6573	12442122	X6635	24234423	X6697	42123424	X6759	23113431
X6450	13431123	X6512	43423121	X6574	42211244	X6636	42421122	X6698	33134431	X6760	33442121
X6451	42233211	X6513	23421244	X6575	23431131	X6637	31212331	X6699	42432124	X6761	24443313
X6452	13234443	X6514	34223312	X6576	23223121	X6638	31312343	X6700	42433213	X6762	34312423
X6453	32113424	X6515	13113344	X6577	21331242	X6639	12343223	X6701	32332113	X6763	12242333
X6454	23422434	X6516	22111223	X6578	31311223	X6640	12322312	X6702	42134312	X6764	33224323
X6455	42211213	X6517	21112443	X6579	11313243	X6641	32444313	X6703	24221333	X6765	43344213
X6456	42431321	X6518	13223342	X6580	24432324	X6642	23422313	X6704	13133131	X6766	31133311
X6457	31311234	X6519	21211322	X6581	42213312	X6643	23443422	X6705	32431344	X6767	11233233
X6458	44432324	X6520	31221344	X6582	32342233	X6644	23321324	X6706	24331322	X6768	42431132
X6459	13333421	X6521	13443124	X6583	32212132	X6645	42333311	X6707	11234234	X6769	23211333
X6460	22133331	X6522	32112322	X6584	11234311	X6646	43312324	X6708	12431113	X6770	34213313
X6461	12322132	X6523	32433221	X6585	11343211	X6647	13324322	X6709	31222312	X6771	23113312
X6462	12231122	X6524	34232332	X6586	33422422	X6648	24221133	X6710	44422211	X6772	33423344
X6463	23234442	X6525	23222312	X6587	31124443	X6649	43321324	X6711	12432334	X6773	42213444
X6464	34322334	X6526	43423244	X6588	11322133	X6650	22233132	X6712	32422344	X6774	13313243
X6465	23121234	X6527	32212334	X6589	22113432	X6651	13233123	X6713	34344323	X6775	42224332
X6466	13243124	X6528	42233244	X6590	21221134	X6652	22433231	X6714	12313112	X6776	13132213
X6467	32434231	X6529	13432124	X6591	23443334	X6653	34332324	X6715	43244432	X6777	22244323
X6468	31121244	X6530	33131232	X6592	43423343	X6654	44432243	X6716	34443134	X6778	22243423
X6469	34422443	X6531	43322312	X6593	24442132	X6655	32442333	X6717	43113112	X6779	13122331
X6470	44242332	X6532	43312223	X6594	33232243	X6656	32432244	X6718	44432432	X6780	32213221
X6471	44244323	X6533	12444234	X6595	42442312	X6657	34212431	X6719	11211334	X6781	23113134
X6472	24442123	X6534	43124231	X6596	24343321	X6658	22421124	X6720	24332112	X6782	13322131
X6473	33132224	X6535	21122132	X6597	21234431	X6659	44313122	X6721	23112434	X6783	23431122
X6474	44343321	X6536	34324442	X6598	34223121	X6660	34443112	X6722	24332244	X6784	42221311
X6475	11343213	X6537	43233122	X6599	33223243	X6661	42311234	X6723	34443321	X6785	23113442
X6476	23223312	X6538	32111242	X6600	12332324	X6662	33443432	X6724	31224442	X6786	12313442
X6477	32112234	X6539	31324221	X6601	23422331	X6663	23432442	X6725	43213122	X6787	34223233
X6478	12324442	X6540	13333221	X6602	42333111	X6664	22234331	X6726	22213433	X6788	43342233
X6479	21122334	X6541	34324312	X6603	24224211	X6665	31133212	X6727	34322444	X6789	21132131
X6480	13243331	X6542	34322134	X6604	21133211	X6666	24421234	X6728	42332233	X6790	34232233
X6481	13334231	X6543	34233113	X6605	31134242	X6667	33233224	X6729	33122223	X6791	32312212
X6482	32113211	X6544	22332433	X6606	24213323	X6668	34432112	X6730	22231134	X6792	13211343
X6483	42113443	X6545	24342331	X6607	21124211	X6669	23423442	X6731	32224432	X6793	31132242
X6484	31344423	X6546	43442223	X6608	43113244	X6670	23323111	X6732	21124433	X6794	23321313
X6485	12324312	X6547	23342343	X6609	33443221	X6671	21133121	X6733	23333211	X6795	34334311
X6486	22443432	X6548	21333213	X6610	43233221	X6672	32421321	X6734	24422213	X6796	11312242
X6487	24432232	X6549	13313344	X6611	23343324	X6673	42211242	X6735	44342342	X6797	42132121
X6488	34242111	X6550	32222133	X6612	23233221	X6674	32111222	X6736	23421323	X6798	44223421
X6489	43342422	X6551	23243231	X6613	24243133	X6675	11242134	X6737	44312224	X6799	13221133
X6490	22434432	X6552	43313321	X6614	44223223	X6676	23131121	X6738	12334434	X6800	42132231
X6491	32311312	X6553	21342213	X6615	33431244	X6677	12324343	X6739	42212344	X6801	43244322
X6492	42321334	X6554	22421333	X6616	23233111	X6678	43213112	X6740	33442422	X6802	21334221
X6493	23123122	X6555	22343422	X6617	42124311	X6679	31113344	X6741	34342343	X6803	43322213
X6494	42322311	X6556	22434322	X6618	24443232	X6680	22311212	X6742	33431242	X6804	43321313
X6495	24333122	X6557	13112343	X6619	42123343	X6681	13332112	X6743	22343123	X6805	22243133
X6496	33322113	X6558	11132242	X6620	32431124	X6682	24324322	X6744	13424422	X6806	12244212
X6497	13244224	X6559	12133442	X6621	34312322	X6683	13332244	X6745	23211221	X6807	43333121
X6498	42312334	X6560	42224431	X6622	33342243	X6684	24331124	X6746	23431223	X6808	21132133
X6499	23132122	X6561	42234221	X6623	31234434	X6685	34423132	X6747	42313221	X6809	13123422
X6500	11224442	X6562	23112342	X6624	13311313	X6686	43211344	X6748	34324343	X6810	44322221
X6501	23444221	X6563	33213422	X6625	32232433	X6687	12313343	X6749	24321132	X6811	44231134
X6502	42423113	X6564	13443313	X6626	32212442	X6688	44232434	X6750	42244312	X6812	23444333
X6503	43443224	X6565	33234232	X6627	12432424	X6689	21133244	X6751	44242312	X6813	32231344
X6504	34234312	X6566	12423343	X6628	31321343	X6690	42113223	X6752	42321312	X6814	12331132



# Infiniti X1-X7000

X6815	13423122	X6877	31121134	X6939	12433124
X6816	42311223	X6878	33213224	X6940	31121334
X6817	22443421	X6879	11313223	X6941	12112344
X6818	42243443	X6880	33424211	X6942	44213132
X6819	22124331	X6881	32442344	X6943	24333344
X6820	32223132	X6882	44242242	X6944	42331342
X6821	13211224	X6883	32433344	X6945	24211321
X6822	23333244	X6884	42322133	X6946	34433223
X6823	34224333	X6885	24321213	X6947	43123443
X6824	22324423	X6886	31342342	X6948	13244323
X6825	11344311	X6887	13324324	X6949	44211224
X6826	43442313	X6888	21113422	X6950	24224442
X6827	43124321	X6889	13312244	X6951	24442242
X6828	33423223	X6890	34242243	X6952	43112313
X6829	32223321	X6891	44233224	X6953	43343122
X6830	12423312	X6892	34231344	X6954	42442422
X6831	23243433	X6893	42332242	X6955	23112223
X6832	32334342	X6894	21121324	X6956	34232242
X6833	43224342	X6895	44311234	X6957	12311244
X6834	31324432	X6896	32111334	X6958	12113323
X6835	12134434	X6897	11333344	X6959	33432221
X6836	33132121	X6898	31221223	X6960	21133332
X6837	32132243	X6899	32244432	X6961	13432221
X6838	23123234	X6900	33113344	X6962	32442423
X6839	12242133	X6901	34224243	X6963	24233312
X6840	24434234	X6902	12232213	X6964	33442431
X6841	42433211	X6903	21131244	X6965	21243134
X6842	44431132	X6904	31321123	X6966	11344234
X6843	43132232	X6905	31133131	X6967	32424423
X6844	24334334	X6906	13344221	X6968	33242211
X6845	13224244	X6907	31234221	X6969	33211332
X6846	13312233	X6908	13442213	X6970	13124434
X6847	34213221	X6909	23122112	X6971	44433233
X6848	22431231	X6910	42123312	X6972	23424432
X6849	23133222	X6911	42132134	X6973	23433124
X6850	12123434	X6912	42431213	X6974	23442432
X6851	43223132	X6913	42131131	X6975	32243422
X6852	21223213	X6914	32443134	X6976	34423334
X6853	31332242	X6915	42123134	X6977	13322113
X6854	44213222	X6916	13233442	X6978	12343324
X6855	13221333	X6917	34331134	X6979	12223444
X6856	42342113	X6918	22433422	X6980	32244322
X6857	33324423	X6919	32443321	X6981	12242344
X6858	22433334	X6920	24324324	X6982	33424424
X6859	32443112	X6921	34233432	X6983	22312323
X6860	12212334	X6922	22233444	X6984	33342232
X6861	44313421	X6923	31213444	X6985	23331224
X6862	21131233	X6924	22443322	X6986	12212442
X6863	43211324	X6925	32232334	X6987	11334222
X6864	24423432	X6926	22334422	X6988	42443212
X6865	24421122	X6927	31321321	X6989	24424433
X6866	24311313	X6928	33243212	X6990	43344431
X6867	11133122	X6929	11212313	X6991	13313423
X6868	32342134	X6930	42433244	X6992	13234423
X6869	32432321	X6931	44322443	X6993	24431132
X6870	43113332	X6932	31221311	X6994	42232113
X6871	43223321	X6933	32312133	X6995	42231213
X6872	23134421	X6934	21113433	X6996	24233211
X6873	24432432	X6935	33311212	X6997	13221322
X6874	44321211	X6936	31131124	X6998	23243123
X6875	12244423	X6937	44313443	X6999	32432422
X6876	42324432	X6938	12212132	X7000	32232134

## Key Kop II Locking Shackles



5 Sizes of Shackle  
4 Sizes of Cable  
Tubular, Duo, Medeco

## Key Kop I Locking Cable

**Coin or Token Operated  
Restroom Locks  
For Service Stations  
Restaurants  
Laundromats, Stores, Etc**



**Heavy Duty  
Security Guards  
for Washers  
& Dryers**



**Full Meter Case  
Armor  
or  
Smaller Coin Box  
Guards with  
Padlocks**



**Locking  
Products for  
Coin Laundry  
Equipment**



**Two Piece Extended  
Tubular Key Blanks  
Fits All Tubular Key Cutters**



**CALL FOR CATALOGUE**

**MONARCH**  
www.monarchcoin.com  
Covington, Kentucky

800-462-9460  
PH: (859) 261-4421  
FX: (859) 261-7403

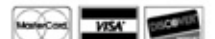

TNL

# Helping the Industry

## One House At A Time

by **Joey Kingma**

**A** woman walks in and places a broken lock and key on the counter and says, “I need a new deadbolt for my house and some extra keys”. The accommodating clerk pulls a new lock from inventory, pins it quickly and cuts a few more keys. The woman pays, walks out with the lock and keys.

This sounds like the beginning of a joke, but instead it is the beginning of a horror story. The horror story ends with over \$250 million dollars of business leaving the locksmith channel.

Let’s review what happened:

1. The woman made a conscious choice about where to shop. She had many other options. Most go to big box stores for selection and price but go to a locksmith for expertise and service. Nothing about that transaction illustrated that the locksmith had any more to offer than the \$7/hour clerk at the local big box hardware store.
2. The clerk may have assumed that by providing what she asked for, he was best serving her needs, but failed to ask any questions or suggest more secure options. He failed the industry.
3. The woman wanted a lock to keep burglars out, unaware of the many options available to secure her home. She assumed that the locksmith would tell her if she were making a bad choice. He didn’t.

You could easily imagine the same transaction occurring at one of those big box hardware stores (you know the ones with the orange or blue signs). In fact, the same transaction occurs every day in every one of them. So why is that important to us?

For the past 20 years, residential business has been shifting from professional channels to the big box type stores. This shift has been driven by several things, including: Consumers lack of education about different locking technologies, Powerful marketing campaigns inviting customers to shop these large stores based on price incentives, very large selection of hardware and low prices.

This trend will continue unless as an industry we begin to fight back. Twenty five percent of the



**This guy may be able to help homeowners with their lumber needs, but is he as qualified as you are to secure their home?**



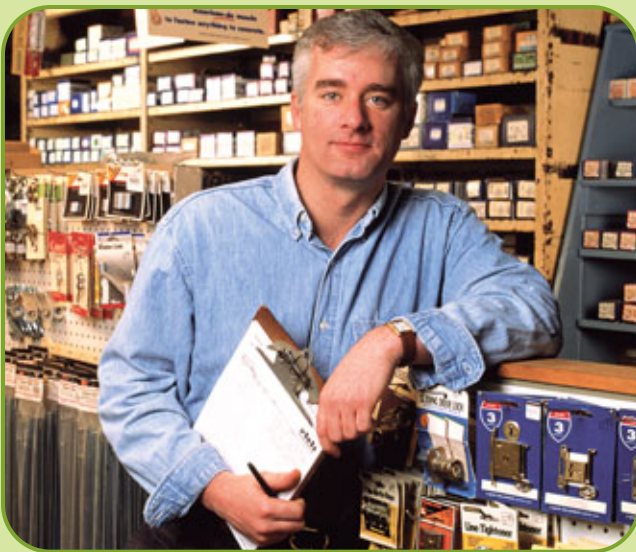

**One of the main reasons residential customers visit their local locksmith is for the security expertise and recommendations that can only come from an expert.**

revenue in the locksmith channel is derived from residential business. Imagine your business shrinking by 25% over the coming years. I think it's worth fighting to keep.

To fight back we must first understand how we fit in the marketplace. Why do consumers shop at a big box store versus a locksmith? If you study the following table, you'll see that typically, a consumer seeks selection and low price when they shop at a big box store. Did you ever try to get expert advice when you shopped at one of those stores? It generally doesn't exist.

Now, why would that same consumer come to your business? They aren't led by some invisible force. No, they come because they expect a

higher level of expertise and professional service options. When you display and recommend (or allow the purchase of) the same products that are available at the big box store, you are making the following statements: We might know about better security hardware, but we think you either won't understand or won't want to pay for it. We'll just dumb-down to the level of the big box clerk for your convenience; We can never buy at the same volume as the big box, so we'll try to sell you the same products at a higher price; we really think the big box store is selling all you need, so go there.

Not exactly the legacy we want to leave behind.

**F**or years leaders in the high security industry have suggested retail locksmiths ask their customers two questions. Do you ever lend out the key to your house? Do you mind if someone makes a copy of your key without your permission? Imagine the scenario at the beginning of the article, but this time imagine that the counter clerk queries the customer about what she is trying to secure and what type of security she desires. "I'll be happy to provide what you need, but are you aware of the vulnerabilities of the hardware you have?" In short, many people in your neighborhood probably have the same front door key as you do and if you ever lend the key out, you have no way of knowing if copies were made. Are you comfortable with this? Because we see the problems associated with this type of system every day, we highly recommend upgrading your home to a UL 437 rated lock system ensuring you that your key will be the only one that opens your door and that you can lend it to anyone without

<b>SECURE INDUSTRIES INC.</b>					
<p><b>Safety Collars</b> Wrenchproof Solid Brass</p> <p>NO. EMWSC3-BRASS Only <b>2<sup>85</sup></b> ea.</p> <p>NO. EMWSC2-CHROME Only <b>2<sup>95</sup></b> ea.</p> <p>NO. EMWSC1-DURO Only <b>3<sup>40</sup></b> ea.</p> <p>The perfect accessory that prevents cylinders from being wrenched out! Special spring insert allows use on all standard Mortise cylinders - a precision fit every time!</p> 	<p><b>Safety Collars</b> Wrenchproof Hardened Steel</p> <p>• I.D. 1 1/8" • O.D. 1 3/4" • THICK 5/8"</p> <p>NO. HH817S - CHROME FINISH NO. HH817B - BRASS FINISH</p> <p>Only <b>2<sup>25</sup></b> ea.</p> <p>Smaller Than Our Standard Collar <b>Great for Store Fronts</b></p> 	<p><b>Aluminum Spacer Rings</b></p> <p>No. EMS223-26D Only <b>75<sup>c</sup></b> ea.</p> <p>No. EMS224-26D Only <b>75<sup>c</sup></b> ea.</p> <p>DURO FINISH</p> <p>No. EMS223-10B Only <b>90<sup>c</sup></b> ea.</p> <p>No. EMS224-10B Only <b>90<sup>c</sup></b> ea.</p> <p>223 1/8 Thick</p> <p>224 1/4 Thick</p> 	<p><b>Mortise Cylinder Spring Type Trim Ring</b></p> <p>NO. SC814B BRASS FINISH</p> <p>NO. SC814S CHROME FINISH</p> <p>Only <b>1<sup>25</sup></b> ea.</p> <p><b>Plastic Shims</b> <b>Plastic Thin Shim Ring</b></p> <p>For use with any kind of cylinder trim ring.</p> <p>NO. SC822P Only <b>5<sup>00</sup></b> bag</p> <p>100 per bag</p>  		
<p><b>PHONE: 1-516-433-0033</b> <b>1-800-999-2534</b> (out of NY)</p>				<p><b>FAX: 1-516-433-8804</b> 9 Kuhl Ave., Hicksville, NY 11801</p>	



**Residential customers are willing to pay more to protect their homes if they believe they are receiving superior customer service and product recommendations from someone who understands security.**

fear of copies being made. It will be a bit more expensive than what you have but it is the only product available that will offer you true security.

By offering the customer the expertise they came in for, you actually earn your pay (and their respect) by being their security expert. You have shared your experience in this industry with them. You help the customer understand why it is important to obtain professional help when dealing with protecting their homes, and illustrate flaws with common locks that most consumers are simply not aware of.

If they take your advice, you will have improved their security, and you will have shifted one sale away from the big box, fighting on a level that mass merchants are incapable of. It's the true David and Goliath story.

Now should you simply pin these words up to the back of the counter and have them rehearsed during quiet times? No, please don't try chanting lines, customers see right through to it. You need to do two things differently.

## 1. Change The Way You Think

You have to change the way you think about your business. When each customer walks through the door, remember why they came to you and where they chose not to shop. Provide them with what they came for, your expertise.

**The National Locksmith® on CD!**

An eight CD-ROM set. Contains 15 years (1988-2002) of the Locksmith's favorite magazine. Over 14,500 pages of indexed and searchable articles complete with photos. Use the index to locate any topic you want to read about. You'll get cool locksmith internet links allowing you to visit important sites with a single click. If you already own 1988-2001 Back Issues on CD then order the 2002 CD to update your Back Issue collection for only \$25.

- ORDER IN THE ONLINE STORE [www.TheNationalLocksmith.com](http://www.TheNationalLocksmith.com)
  - FAX IN THIS COUPON (630) 837-1210
  - PHONE IN CREDIT CARD ORDERS (630) 837-2044
  - ORDER BY MAIL
- Send me 1988-2002 Back Issues on CD  
\$99.00 (US add \$8 s/h, Foreign, Canada add \$20 s/h, US Funds)
- Send me the 2002 Back Issues on CD  
\$25.00 (US add \$8 s/h, Foreign, Canada add \$20 s/h, US Funds)
- I've enclosed a check or money order for \$ \_\_\_\_\_  
or Charge my  VISA  MasterCard  
 Discover  American Express

Credit Card # \_\_\_\_\_ Exp. Date \_\_\_\_\_  
 Signature \_\_\_\_\_  
 Your Name \_\_\_\_\_  
 Shop Name \_\_\_\_\_  
 Address (no P.O. Boxes) \_\_\_\_\_  
 City \_\_\_\_\_ State \_\_\_\_\_ Zip \_\_\_\_\_  
 Phone \_\_\_\_\_

**Mail your Order & Payment to...**  
 The National Locksmith  
 P.O. Box 77-97592 • Chicago, IL 60678-7592

OID 03/04





**You'll be able to sleep better at night knowing your customers are safely protected in their home.**

Believe in what you offer and you will naturally offer the appropriate products. The customer may not always listen, but at least you will be able to sleep at night knowing that you tried.

## 2. Change What You Recommend

You recommend products in two ways, verbally and by what you show in your showroom. The previous point covers the verbal recommendation, so we'll concentrate on the showroom area. Most walk in traffic is residential. Commercial traffic will likely be in for a pick up or to set an appointment, not to browse. Commercial customers are typically sold in the boardroom not the showroom, so set your showroom with an emphasis on residential. Get rid of any product that appears on the shelf of a big box store. I know it's hard to do but you've got to draw the line there. Then make sure that every display promotes higher security than what can be found in a big box store. If products share a keyway with a product in the other channel, yes, you guessed it, get rid of them. You understand and sell security. The real stuff, not the fake stuff printed on the fancy boxes down the street. When a customer walks in, proudly promote what you sell and why.

Remember, this is a high stakes game with real consequences to your business and to the entire industry. You won't lose low security hardware sales by promoting higher security products. Instead, you'll make more high security sales and elevate your reputation in the community. You'll be improving the security of all of your customers, not just the commercial customers. You might even turn a better profit at the end of the year by not feeling the pressure to squeeze every penny out of your residential hardware for fear of being compared to the "other" channels. It's the right thing to do. **TNI**

# PERSONAL and PISTOL PROTECTION

**NEW  
PRODUCT!**

**Model  
PV-1-IPB**



**Made In  
U.S.A.**

- Illinois Lock D900 Series pushbutton lock provides security while allowing easy owner access.
- Mounts easily in car trunk for use by law enforcement agencies.
- Suitcase-style handle for easy transport.
- Padded with heavy duty felt and egg crate foam to protect contents.
- We will custom build safes in the U.S.A. for any shape or configuration you need.

**See us at ALOA Show Booth 856**

**The Perfect Protection for  
Any Application**

**Order through your  
Locksmith Distributor**



**PERMA-VAULT®**

**Safe Company**

*Security solutions since 1978*

**Phone: 800-662-3360 ■ 215-293-9951**

**Fax: 215-293-9952**

**We're just a click away at  
[www.perma-vault.com](http://www.perma-vault.com)**



# Lockmasters Security Institute

## Expands Education Center

**M**arking nearly 50 years in training security professionals, Lockmasters dedicated its expanded 22,300 square foot, state-of-the-art education facility in May.

Lockmasters Security Institute in Nicholasville, Kentucky, is dedicated to a quality education program, which meets or exceeds the expectations of those concerned with operating within the security community.

“There have to be trained people in this world to protect us over all that is happening, and that is why we are here,” said Clay Miller, chairman of Lockmasters, Inc., as he cut the ribbon at the dedication ceremony.

Nearly 150 people, including state and local government, homeland security and education officials, along with industry vendors, students, locksmiths and other security professionals attended the ceremony.

The building contains separate classrooms for key lock training, physical security and anti-terrorism



training, fundamentals of electricity and electronic access control training and GSA training. The building is also the home of the Harry C. Miller Lock Collection. Housed in the building's main atrium lobby, the collection is considered to be America's most comprehensive collection of safe locks.

The key lock training classroom, which is also used for tactical entry courses, includes a drive-in bay area enabling locksmiths to learn the entire car in a sheltered environment. There are thirty individual work stations, equipped with Ilco key machines and other tools, set up to teach everyday locksmithing techniques.

Through a partnership with Central Kentucky Technical College, LSI students can work toward a Security Management Coordinator certificate, or simply earn college credits needed for career and personal advancement.

LSI's expanded facility builds on the original 7,500 square foot school, which opened in 1997. Lockmasters has already graded another 10,000 square feet on an adjacent lot in anticipation of future expansion.

Lockmasters was founded by Harry C. Miller in 1955, and training classes started shortly thereafter. **NLI**





# TheNationalLocksmith.com

Technical forums, chat, online store, plus  
visit our sponsors...

## WEB REVIEW

### Select Product Ltd.

<http://www.select-hinges.com/>



## SELECT HINGES

Geared To Ship In 48 Hours !

Select Products Limited is a manufacturer of aluminum continuous gear door hinges. The Select continuous gear hinge is a heavy-duty hinge system designed for use with wood, aluminum, hollow metal doors and frames for both exterior and interior entrances.

Thousands of Select hinges have been specified for schools, hospitals, storefronts, offices, and many other types of commercial and industrial building applications. Select continuous gear hinges can be used for both new construction and retrofit.

On the web site you'll get a great overview of the product line, including the hinge specifications and applications. This makes choosing the right product easy. Sagging doors often produce locksmith calls and

these products offer a highly profitable solution.

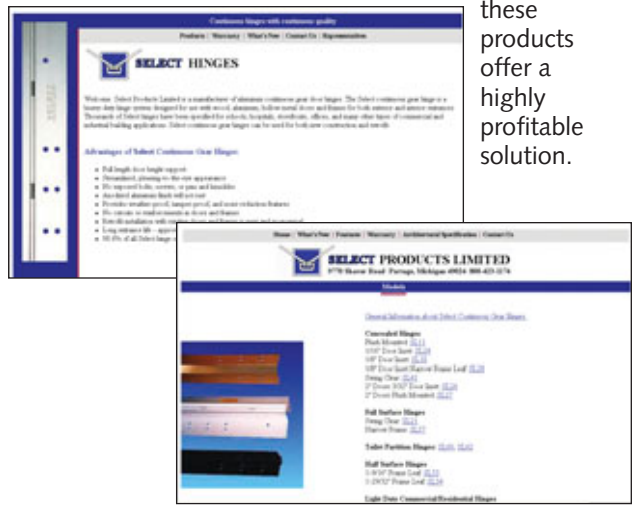

### A-1 Security Mfg. Corp.



[www.demanda1.com](http://www.demanda1.com)

### A&B Safe Corporation



[www.a-bsafecorp.com](http://www.a-bsafecorp.com)

### Abloy® DiskLock Pro



[info@abloy.ca](mailto:info@abloy.ca)

### Adrian Steel



[www.adriansteel.com](http://www.adriansteel.com)

### DiMark International



[www.dimarkinternational.com](http://www.dimarkinternational.com)

### Framon Mfg. Co.



[www.framon.com](http://www.framon.com)

### Herbert L. Flake Co.



[www.hflflake.com](http://www.hflflake.com)

### Gator Tools Co.



[www.gatortools.com](http://www.gatortools.com)

### HPC, Inc.



[www.hpcworld.com](http://www.hpcworld.com)

### Indiana Cash Drawer Co.



[www.icdpos.com](http://www.icdpos.com)

### International Locking Devices, Ltd.



[www.gatelock.com](http://www.gatelock.com)

### KSP



[www.iccore.com](http://www.iccore.com)

### Major Manufacturing



[www.majormfg.com](http://www.majormfg.com)

### Midwest Wholesale

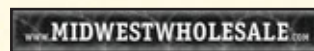

[www.midwestwholesale.com](http://www.midwestwholesale.com)

### McDonald DASH Locksmith Supply

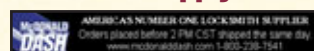

[www.mcdonalddash.com](http://www.mcdonalddash.com)

### MDS, Inc.

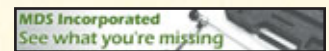

[www.mdsincorporated.com](http://www.mdsincorporated.com)

### Monaco Lock



[www.monacolock.com](http://www.monacolock.com)

### National Auto Lock Service, Inc.



[www.laserkey.com](http://www.laserkey.com)

### Omaha Wholesale Hardware

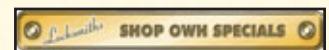

[www.omahawh.com](http://www.omahawh.com)

### RS2 Technologies



[www.rs2tech.com](http://www.rs2tech.com)

### SecuraKey



[www.securakey.com](http://www.securakey.com)

### Securiton Magnalock



[www.securiton.com](http://www.securiton.com)

### TekTone

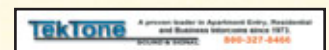

[www.tektone.net](http://www.tektone.net)

### Yale Security Group

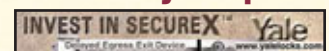

[www.yalesecurity.com](http://www.yalesecurity.com)

Manufacturers and distributors... join the high profile locksmith web site and you'll be featured here!

Call Jeff Adair (ext. 15) or Debbie Schertzing (ext. 16) for details. (630) 837-2044

Taking Industry Products for a...

# TEST DRIVE

## Pocket Size Decoder

by HPC



### IN SUMMARY:

**DESCRIPTION:** A pocket size key decoder.

**PRICE:** \$189.00

**COMMENTS:** Takes the guesswork out of decoding keys.

**TEST DRIVE RESULTS:** Easy to use, accurate and well made.

### THE NEED:

How often have you been given a key and asked to use it for the basis of a master key system, or maybe to decode what the key is to help establish the bitting of a current master key system? Maybe you were given a key that had to be wiggled a lot to make it work and they wanted a better working key. How about decoding a Medeco key to make another copy for a customer.

Do any of these sound familiar to you? I bet you can come up with a dozen similar situations that have happened to you over the years and you wished you had a fast, effective and accurate method to solve all the "opportunities" you were given.

### THE ANSWER:

Well, guess what? An answer does exist and it is the HPC POCKET SIZE DECODER model HKD-75. It comes as a kit, complete with the decoder and 111 information cards. They even numbered the cards to match the 1200CMB code machine cards so you can match them up easily and be sure you are using the same system when you cut the keys. This is important when you realize the number of different systems some of the lock companies have implemented over the years.

The Pocket Size Decoder determines the original factory depths of most popular domestic pin and disc tumbler cylinder and automotive keys. It is ideally suited for giving the correct bottom pin size when re-keying new or worn cylinders. It is also an effective timesaver

when used along with precision color pin assortments or when using original pins.

### USING THE TOOL:

The Pocket Decoder is very easy to use. You just determine the card that matches the system you are using and insert the card into the top slot of the decoder. Next you place the key you need to decode into the tool through the opening on the lower right hand corner. Slide the key in until the first cut lines up with the depth pin and read the depth on the card by seeing where the indicator is located. Record that information and go on until you have decoded all the cuts on the key.

Since the depth pin is chisel pointed and pivots, it allows for easy decoding of Medeco angles and works as well for Corbin high security keys also. The depth pin has a lever attached to it that will point to either a right hand or left hand cut for the high security keys, thereby eliminating the guesswork out of decoding them as well.

In addition to the depth and angle information you get from decoding the keys, each of the 2" x 4" information cards list the manufacturers depth and space specifications. If you are given a key that requires wiggling to work, you can often decode the key and cut the depths to the closest cut shallower than shown on the card. Many times this will eliminate the need to wiggle the key and can save you the headache of removing the lock and decoding it that way. This is especially true of GM ignition keys that have been "erased"

by all the weight customers seem to like to have on their rings.

The POCKET SIZE DECODER Model HKD-75 comes complete with a handy plastic carrying case, 3 shims and the before mentioned 111 information cards. The shims help keep the key straight in the decoder, a critical factor when accuracy is a must.

### PRICE:

The complete HPC HKD-75 kit has a suggested retail price of \$189.00.

### COMMENTS:

This is a well made, accurate product that does what it is advertised to do. A real time saver that takes the guesswork out of decoding keys and gives the locksmith another method of doing a job the local hardware store cannot do.

### CONCLUSION:

HPC has given us the answer to an everyday problem with this tool. It is made to last a longtime and if you keep it in the case it should last a lifetime. Well worth the \$189 retail price because it will pay for itself in time saved.

### ORDER INFORMATION:

For more information contact your distributor or HPC at:

**HPC Inc.**

3999 N 25th Ave  
Schiller Park, IL 60176

Phone: 847-671-6280 or 800-323-3295

Fax: 847-671-6343

Email: [hpc@hpcworld.com](mailto:hpc@hpcworld.com)

Website: [www.hpcworld.com](http://www.hpcworld.com)





# AN INCREDIBLE DEAL ON KEYPACKS PLUS A FREE GIFT?



## WHAT IS THIS, YOUR BIRTHDAY?

When you order any STRATTEC XL Keypack, you get more than just an assortment of XL keys. You get the most convenient way to build an immediate inventory of a variety of the XL keys your customers need – at a discounted rate – PLUS a FREE gift. All just for ordering the products you know you can trust. Shouldn't every shopping experience be this convenient?

PART NO.

**708751** | **MASTER PACK** Variety of domestic and import transponder keys. **GET THE TRAVEL CHAIR FREE!**

**708752** | **EXPERT PACK** Variety of domestic and import read-write keys. **GET THE IGLOO COOLER FREE!**

**708753** | **PRO PACK** Variety of domestic and import molded head non-transponder keys. **GET THE MAG-LITE FREE!**

CALL YOUR DISTRIBUTOR NOW to get one  
of these gifts FREE WITH EACH KEYPACK\* ORDER.



\*While Keypack supplies last.

Circle 276 on Rapid Reply

©2004 STRATTEC SECURITY CORPORATION All rights reserved