

The National Locksmith®

\$5.00

CODES
MASTER 1-3200 PART 1
page 111

March 1995
Volume 66, No. 3

Padlocks Lock Up The World

Puzzles, Padlocks & Profits
page 49

Bikes, Motorcycles & Trailers ... Oh No!
page 54

Servicing The Medeco System Series Padlock
page 56

Who's Cookin' With Padlocks?
page 62



M I N I - S E C T I O N	
• <i>Up In Smoke!</i>	page 68
• <i>Fire Sale</i>	page 74
• <i>Buying Fire Safes: Avoid The Heat</i>	page 81

Don't Miss...
DIRECT MAIL BONUS CARDS
see center spread

CONTENTS

March 1995 • The National Locksmith • Vol. 66, No. 3

FEATURES

8

Keys, Cars & Scams
Telemarketers and your money.

10

Mosler GSA Files, Part 2
Finish up the Mosler drilling.

21

Corbin Russwin Emhart High Security

32

The 1994 Jeep Cherokee

38

CCTV - Just The Beginning

49

Puzzles, Padlocks & Profits

54

Bikes, Motorcycles & Trailers ...Oh No!
Accessory lock applications.

56

Servicing The Medeco System Series Padlock
The new Medeco padlock line.

62

Who's Cookin' With Padlocks?
Padlock collector, Tom Gallian.

68

Up In Smoke!
Torching the Sentry 3140 and Meilink 251 fire safes.

74

Fire Sale
Opening the burned fire safes.

81

Buying Fire Safes: Avoid The Heat
Fire safe definitions and ratings.

106

Making The Cut In Aluminum Door Service
Aluminum door lock installation.

CODES 111

Master

1-3200, Part 1

DEPARTMENTS

5

COMMENTARY

6

LETTERS

16

NEWSMAKERS

48

BEGINNER'S CORNER

86

THE LIGHTER SIDE

96

THRU THE KEYHOLE

101

TECHNITIPS

110

BITS & PIECES

122

TEST DRIVE

Click on the article you wish to read

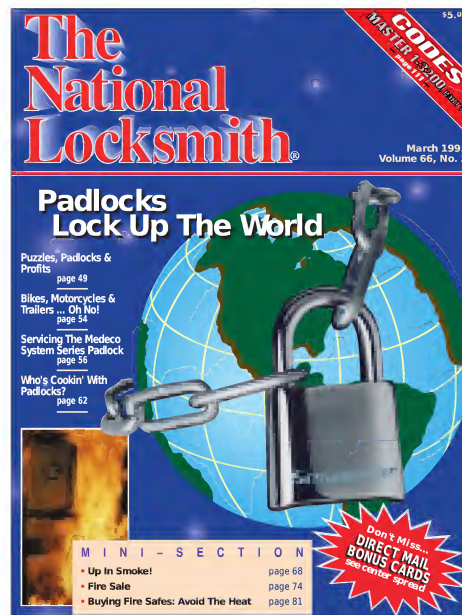

On The Cover

There's a whole world of padlocks out there ready to help you secure additional profits! Learn more in this issue. PLUS! We have some hot articles for you on fire safes!

Editor/Publisher Marc Goldberg
Managing Editor Tom Seroogy
Art Director Jim Darow
Production Director Edgar Shindelar
Technical Editor Jake Jakubowski
Technical Writers Carl Cloud, Steve Gebbia, CML, Eugene Gentry, Bill Heine, Michael Hyde, Giles Kalvelage, Brian Kleiner, Ph.D., Dale Libby, Tom Mazzone, Dave McOmie, Don Probasco, Sara Probasco, Robert Sieveking
Director of Sales & Marketing Jeffrey Adair
Advertising Account Manager Debbie Schertzing
Circulation Manager Nancy Town
Accounting Manager Diane DeGrace
Administrative Assistant Michelle Buckley
Advisory Board Mike Elsberry, Steve Dyson, Buddy Logan, Sean DeForrest

National Publishing Co.
The National Locksmith® ISSN #0364-3719 is published monthly by the National Publishing Co., 1533 Burgundy Parkway, Streamwood, Illinois 60107. Second class postage paid at Bartlett, Illinois 60107 and additional mailing offices USPS 040110. Subscriptions \$36.00 per year in the USA; \$50.00 per year in Canada; \$59.00 in all other countries. Single copies \$5.00 each. Postmaster, please send change of address to National Publishing Co., 1533 Burgundy Parkway, Streamwood, Illinois 60107. ©1995 by the National Publishing Company. All rights reserved. Printed in the U.S.A.



Questions or problems with your subscription?
Call (708) 665-0540
 For all other inquiries, call
 (708) 837-2044, or fax (708) 837-1210.

COMMENTARY

Have a computer? Talk to The National Locksmith Online!

Here's some news from our What-Will-They-Think-Of-Next Department! The Associated Press recently reported that car thieves have found a new target.....AIRBAGS!

"It's the fastest growing scheme in stolen parts," says Jack Denver, who oversees fraud control programs for USAA auto insurance. "You can get a brand new Mercedes or other high priced car; they'll forget everything else and go to the airbags."



Marc Goldberg
Editor/Publisher

Naturally, due to ease of removal (i.e., rip-off), the driver's side airbags are the ones being stolen. Some of these parts are worth about one thousand dollars. Perhaps we'll be seeing some changes upcoming from the auto manufacturers to make them harder to remove without affecting their function. Of course, if that happens, you'll read about it here first. Because you can be sure that any change to make it harder for crooks, will not be making your life any easier. But we'll keep you posted!

I have been having a great time talking to many of you via E-mail. And if you are currently using E-mail, send me your electronic address if you haven't done so yet. I have sent codes and newsflashes to those of you who have registered with us.

You can get access to us this way through Genie, America Online, CompuServe, Prodigy, etc., simply by using the proper electronic address for the magazine. (See the addresses listed here.)

By the time you read this, we will have hosted our first online forum on America Online. I'll let you know how it goes. Dave McOmie, Dale Libby, Carl Cloud and I will be chatting about safes live and online in a password protected room. We have to have your subscriber number and E-mail address to be able to include you in these forums, so please contact me for more details. You can get a free

America Online trial membership by calling them at 800-827-6364.

While we are talking about computers, I have read some information about a newsgroup on the internet called alt.locksmithing. I have been keeping abreast of the happenings there, and find them to be mostly harmless. Yes, the people there are unrestricted and I do not post drill points or codes there.

However, these people are interested in honest discussion about locksmithing. We have to remember that none of us were BORN a locksmith. We all LEARNED to be one. So we have to understand that in this information age, people will want to know more and more. The important thing is to encourage a good professional interest without giving the bad guys any more ammunition.

I have also been placed on a new locksmith mailing list thanks to Dominick Atanasio. A mailing list on the computer means that you receive all the postings via E-mail so that membership can be controlled and the posts are more private. E-mail to Dominick at locksmithing@hamlet.planet.net for more details.

I see where another outfit has started a buying club. Membership costs fifty bucks then you are supposed to be able to save money from discounts by participating suppliers. First of all, I don't notice too many participating suppliers. That may be because your suppliers believe they should already be offering you the best possible price, whether or not you pay a fifty buck fee to a third party.

Let the buyer beware!

America Online: NATL LOCK

Use the above address if you are on AOL.

Internet: natllock@aol.com

Use the Internet address if you are not on AOL.

LETTERS

Comments, Suggestions and Criticisms

The National Locksmith is interested in your view. We do reserve the right to edit for clarity and length. Please address your comments, praise, or criticism to Editor, **The National Locksmith**, 1533 Burgundy Parkway, Streamwood, IL 60107. (Or E-mail us at the E-mail address above.)

Welcome To E-Mail

Dear Marc:

I'm glad to see one of the locksmith industry publishers begin to move into the modern world. I hope others follow suit and compete for my electronic attention. Thanks for getting started.

One suggestion: It is not clear to me from the way it is printed, whether your AOL address is NATL LOCK



It's not safe
unless it's
Schwab Safe.

[Click here for more information](#)

America Online: NATL LOCK

Use the above address if you are on AOL.

Internet: natllock@aol.com

Use the Internet address if you are not on AOL.

✉ - letter

✉ - E-mail

(with a space) or NATLLOCK (with no space). I am trying to send it both ways.

You might also mention, in E-mail or the magazine, that there is an internet news group for locksmiths that is interesting sometimes.

I teach locksmithing at the Pine Technical College in Minnesota. You have done some education issues profiles of us in the past. If you hear of anyone searching for comprehensive locksmith education at an accredited school, we would appreciate the reference.

John Heckman, CML
Via E-mail

Editor's Note:

Our America Online address is NATL LOCK, with a space between the two words. For those wishing to write from another online service, you can use our Internet address which is natllock@aol.com.

E-Mail Introductions

Dear Marc:

I am happy to see that we can communicate on-line. Please add me to your E-mail address book, I will do likewise.

I realize you are a busy man, but I thought I would take the time to tell you a little about myself. Sometimes people in your position do not get a chance to interact with your subscribers as much as you would like to. I would also like to take this opportunity to tell you how valuable your magazine is and thank you for the way it contributes to the locksmithing industry.

I am the Chief Deputy of a small midwestern county sheriff's department. I am also the jail administrator. I am a member of ALOA and have been doing locksmithing as a part time business for many years. My business is operated out of my home and has to fit

in with my other responsibilities. Sometimes I think the industry doesn't realize that there is a place for the small part-time business. Our entire county only has a population of about 13,000. It would be pretty hard to scrape out a living full time.

The nearest full time locksmith is about 45 miles away. He and I get along well and do not hurt each other's business. He can't afford the down time required in travel time to service my area. I don't cut prices and try to do quality work. In emergencies and jobs I'm not really equipped for I always recommend him for the job.

Yes, law enforcement officers open car doors around here but there are times I'm just not available and who else can they call. I have refused to open car doors while I'm on duty to avoid a conflict of interest and the sheriff agrees with me. The nearest supply house to me is at least 100 miles away and the next one is in Minneapolis. No salesmen call on me so the only way I can stay abreast of the new products and information is through your magazine and Keynotes.

Security is important, even in the rural areas, but is probably twice as hard to sell. Big city locksmiths are often so busy they only have enough time to get the job done. I try to provide my customers with the most economical way to achieve good sound security. Not to sound egotistical but, I try to sell myself and gain the customers trust. It's worked quite well for me here.

Fred C. Meeder
Via E-mail

Another Happy E-Mailer

Dear Marc:

Being able to send you Reader Reply numbers by E-mail is great. I can not wait for the online forums.

James DeM aranville
Via E-mail

About Face?

Dear Marc:

You have apparently done a 180° turn in your position on locksmith licensing. You have gone from “con” to “pro.” I am voraciously opposed to locksmith licensing. A license is a tax no more no less, the politicians would just love it. More money for them to squander.

Your premise that it would clean up the locksmith industry is unfounded at best. There have been stories printed in the The National Locksmith of crooked locksmiths.

To illustrate a point, there are crooked doctors, lawyers, auto mechanics, builders, ad nauseam, who are all licensed or otherwise regulated in my state of Michigan. A crook is a crook is a crook and no amount of regulation will weed them out.

I am a retired mail carrier and have been a practicing locksmith since 1985. I love the work and do my best to perform well. However, the net I earn is well below the poverty level. My locksmithing is halfway between a hobby and a nice subsidy. My area will not support a full time locksmith. For those that have to earn their living full time at locksmithing licensing is just another burden that slices into their profits.

Tom Seager
Michigan

Editor's Note:

Tom, what convinced me to change my mind is that the alarm installers are working on making it illegal for you to install an alarmed panic device. In Florida, the mechanics have made it illegal for you to work on an ignition lock without a mechanic's permit. If we don't act now to insure our own future, someone else is going to eat our lunch.

More On The Edge

Dear Marc:

Thanks for the national exposure to the public sale of locksmith tools. (See the December 1994 The National Locksmith “Commentary” regarding The Edge Company.) I am trying to enlist my local fellow business owners to mass reply to this. I'm sending you another ad for locksmith tools by The Edge Company, let's see if we can convince them to stop.

Bryan Miltimore
Maryland



**Lockmasters has a
44 year history of
training security
professionals.**

Click here
for more
information

VIEWPOINT: KEYS, CARS & SCAMS

Opportunity or scam. Sometimes it's hard to tell the difference. Take it from someone who's seen the results of both.

The opinions expressed in Viewpoint are not necessarily those of The National Locksmith magazine nor of The National Publishing Company.

There has been a lot of talk lately about tryout key scams. "Make-a-buck-fast" telemarketing companies that make wild claims about the abilities of "magic" keys. These outfits employ high pressure phone salesmen to call locksmiths and car repossession companies selling tryout sets, sometimes erroneously calling them "master keys" or some other misleading name. In some cases the telemarketing company will accept only one form of payment and that is C.O.D. - cash only.

In the past few months many locksmiths have bought from these companies, and quite a few have been dissatisfied. Then comes the next problem; how to get a replacement set or a refund. The locksmith then finds out that for one reason or another this is not possible. Sometimes it is because the "security seal" has been broken. Sometimes it is worse, no return address or phone number to contact the seller.

One such incident as this happened to Mr. Wayne Bradley of A.B.C. Locksmithing in Oklahoma. Around midsummer this last year he received a call from one of these telemarketing firms. They were from somewhere in Florida, he said. He agreed to purchase the tryout set. After two months or so of giving them what he thought was a fair try, he decided that he was not pleased and wanted his money back. His invoice reflected no way of contacting the selling company.

By coincidence the company called him in an effort to sell him the same product that he was trying to get his money back on. He let the sales

representative know that he wanted a return authorization. She gave him a number to call for his complaint. That number was 800-627-9433. This is the phone number to Aero Lock in Memphis, Tennessee. I ought to know. I own the company.

Naturally I was puzzled at Mr. Bradley's request for a refund on our GM Tryout set. You see, he has never purchased one from us. Then it dawned on both of us what had happened. The sales representative must have not wanted to refund Mr. Bradley's money and also not have realized before she called him, that someone from her company had already sold him their GM set.

So, for some reason she gave him my phone number to get him off her back. Pretty low thing to do if you ask me. Especially since my company had nothing at all to do with the production of Mr. Bradley's set. Our name is not associated with it at all. Was this company trying to get someone else to pay for their mistake? It would seem that way.

Let me go on record as owner of Aero Lock and say that we have never had a manufacturing facility in any location other than Memphis, Tennessee. We do not employ telemarketing people. We have not in the past and we will not in the future. We did not produce the set that Mr. Bradley was having trouble with.

Where does that leave him? I hate to say this but, while we sympathize with him, Aero Lock is understandably not willing to take respon-

sibility for a tryout set it did not produce. I have spoken to Mr. Bradley and he understands this.

Now you may be asking yourself this question: How do I as a locksmith protect myself from such scam operations? To help answer this question I called Dennis Baxter. (Yes my competition!) Now if competitors can agree on some pointers for locksmiths to use to protect themselves, then it would be wise to listen.

Here we offer our best advice:

1. Be leery of telemarketers. They could be legit but listen to them with caution.
2. Is the company you are thinking about doing business with willing to send you a catalog of its products? A "No" here, and you had best move on.
3. If they primarily use a P.O. box,



David Parrott of Aero Lock

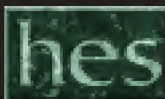

will they tell you the street address? Once again a "No" and they do not need your money. If they are vague with an " Oh, we're in Northern Dakota" you better hightail it away.

4. Will they give you their phone number? Or do they insist on calling you back? Will they offer this information freely and quickly like they are pleased that you want it?

5. When you call the number they give you, how do they answer the phone? Is it with the name of the business or is it simply a "Hello"?

6. What is their guarantee?

7. What are the conditions of a return?

Any hem-hawing on these questions is cause to be suspicious. Likewise, be leery of statements like "We've sold a lot to satisfied customers in your area."

My answer would be, "Okay, gimme names!"

Lastly, does their local phone company know they exist? Now, that last one may seem strange but really it is not. You might be surprised to find out that such a company may sometimes not even have a business license or the address they give is to an abandoned building or even a vacant lot. I know of a diamond scam that gave the address to a vacant lot. Nice try, but I checked!

So in closing, let me say that the vast majority of manufacturers and suppliers are legitimate. They strive to produce a quality product, and the suppliers do their best to sell at a fair price. They need to in order to keep your business. And keeping your business is how they keep food on the table so they are not going to rip you off.

Any questions or comments? I would be glad to hear from you. My number at Aero Lock is 800-627-9433. Dennis told me that he invites your questions and comments, too. He can be reached at 619-390-1197.



HPC, Inc. Designing Excellence and Manufacturing Quality since 1956

[Click here for more information](#)

Mosler GSA Files

Part II

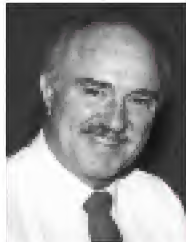

by
Carl Cloud

This month we pick up on drilling and repairing a Mosler GSA File.



1. Drilling the hard plate with a pressure bar rig.

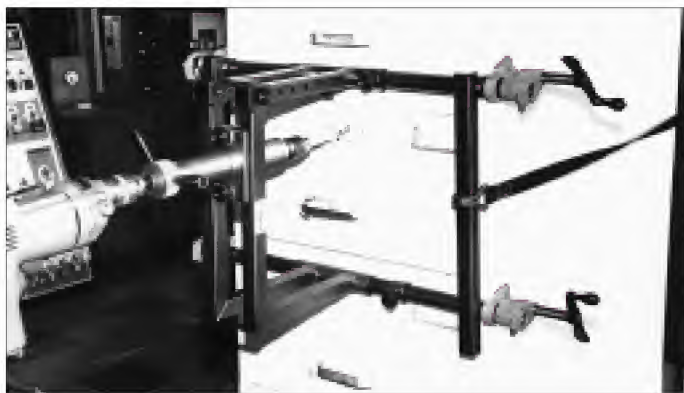

2. The fixed drilling rig - A Magnum 357.

Today we pick up where we left off last month - tackling the hard plate. Now is the time to bring in the muscle. To drill hard plate correctly and efficiently, you must have some type of a pressure drilling bar or fixed rig. The unit in the photograph one is a Lee Drilling Rig, usually referred to as a pressure bar rig. It is equipped with a two speed Hornet motor, a chain hook up for anchoring and a handle that adjusts in length to increase leverage. Other brands on the market are the Collins, Keedex and Strong Arm, just to name a few. Each has its own features of design and all work equally as well.

The advantages of a pressure bar rig includes being very compact and mobile. It is easy and quick to hook up and can be used in virtually any situation. It allows you to drill at any angle. It's the work horse for the safe technician. On the other side of the coin, it is a very unstable method of drilling. Plan on breaking a few drill bits as you inadvertently lean off from

the angle of drilling. The deeper the hole, the greater the chance of breaking a drill bit or angling off and missing your target.

Photograph two shows a fixed drilling rig. And again, there are several brands to choose from. This one happens to be an early model of the Magnum 357. I chose it because it is compact, designed with few moving parts and easy to use and quick to setup. It is a drill rig that allows up to 30° angle drilling. A fixed drilling rig is essential for those precise, "I've got to hit the location exactly," drilling jobs.

The disadvantages of this model are you can't use it in all situations; such as a vault door or a safe that has been built-in or the door is flush with the wall. The new version, distributed by Lockmasters, is fitted with magnets to affix the rig to the safe door. A recent newcomer to the fixed rig market is the mini rig by Strong Arm. This rig is very compact and proving to be extremely versatile. It is becoming a favorite of many safe technicians.

If your bank account hasn't found the funds for a drilling rig, lay the cabinet on its back. Use your own body weight to muscle a hole through the hard plate. It may not look too professional, but with perseverance it will get the job done.

The next item on the list is a good carbide drill bit. We could spend the next four pages evaluating, discussing metallurgy, drill point pressure versus speed, negative and positive cutting edges, etc. The bottom line, there are some excellent carbide bits designed for safe drilling and they are quite inexpensive. For example, the bits



3. An otoscope helps to see into the hole. A simple pen light will do.

from Strong Arm Security start as low as \$4 for a 1/4"x4". A 1/2"x6" is only \$7.50.

A quality carbide bit will have the tip brazed onto the shaft. This will allow high speed drilling (5000 RPM) as well as slow (350 RPM). The heat generated by high speed drilling will cause a silver soldered tip to come loose from the drill shaft (such as the tip of a common masonry bit). To determine how the tip is secured to shaft, file a groove into the joint between the drill shaft and the carbide tip. If the metal color is silver, it's silver solder. If the color is brass or gold, the tip has been brazed onto the shaft.

Mosler uses two types of hard plate in their G.S.A. containers. Tempered and alloy steel. 'Relsom' is Mosler's alloy hard plate. It is a formulated composite of extremely hard steel mixed with chips of carbide. If you are drilling through the skin of the drawer and suddenly pass through a short void of space, Relsom will be your next barrier. It is easily identified by the very rough textured surface. Drilling Relsom requires alternating punching and drilling. The punching breaks up the pieces of

carbide — the drilling wears away the rest. Plan to use four, six or possibly eight carbide bits for a 1/4" thick plate.

I have no idea what percent of Mosler G.S.A. containers have the Relsom hard plate. In my experience, I have found about one out of 25 have it. It may be, that some special military facilities will have all their containers built with the Relsom hard plate.

Tempered hard plate is the normal protective steel used by Mosler. It is a good mixture of steel molecules that have been heated and tempered to a Rockwell scale of hardness. A metal file, for example, has been tempered to give it the hardness to file away other softer metals. The tempered hard plate will stop the common high speed drill bits. Carbide is harder than man can temper steel. Therefore, a

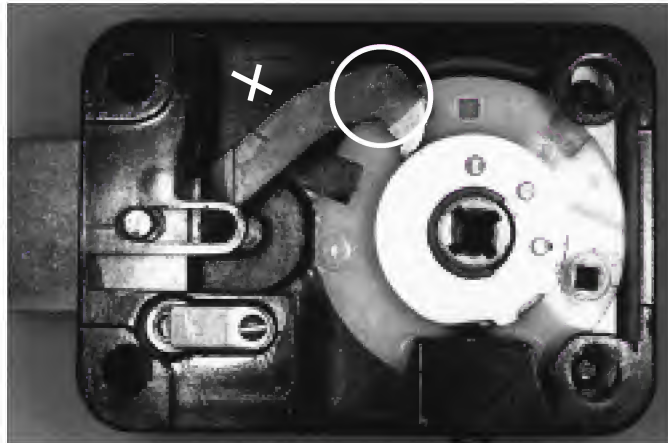

4. An X-ray view of the Mosler 302 lock. The circle is drill area for the fence. The X is a secondary scope location.

sharp carbide tip bit backed up with the correct amount of pressure at high or low speed will penetrate tempered hard plate.

Carbide drill bits are designed to drill holes into very hard materials. If you attempt to drill softer metals, you will run the risk of snagging the bit in the hole and breaking off the brittle tip. Therefore, after you have drilled through the hard plate, you should switch back to a standard high speed bit for the final hole through the lock

Major

MANUFACTURING, INC.

Installation Tools

The Professionals Choice

[Click here for more information](#)

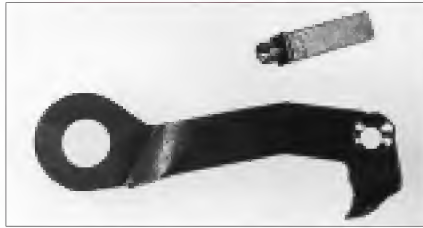

5. The fence drilled out of the lever.

mounting plate and the lock case.

The lock case is made of a zinc aluminum alloy. It is resistant to drilling, but it is also a soft material. Drilling into the lock case should be done in short bursts. Don't get too anxious — take your time. The drill motor speed should be at a slow RPM. When aluminum becomes hot, it also becomes sticky — it will clog and cling to the cutting edges of the drill bit. Hard pressure drilling will cause the bit to quickly 'thread' itself through the final opening of the hole and slam into your target. We don't want to damage anything that is working!

After completing the hole into the lock case, take a peek into the hole. I'm using an otoscope. It has a light source and a magnifying lens. But since the hole is only 3/4" deep, you could possibly use your naked eye or a simple pen light to illuminate the bottom of the hole. (See photograph 3.)

If you have drilled correctly, you will see the area circled in photograph four. The lever is made up of two pieces — the main lever and the fence. During manufacturing a hole was drilled in the head of the lever and the fence was inserted and soldered into place. What you may not be able to see in the photograph is an outline of a solder joint where the fence is secured to the lever. Remember, the fence is facing into the lock case, away from your view.

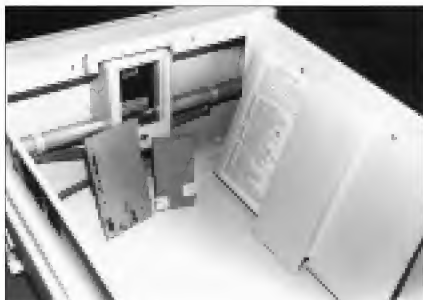

9. Slide the back drawer cover up and remove the two pieces of hard plate.



6. Twenty minutes of labor should have the cabinet looking like this!

Pick up that small drill motor that we used to make the initial hole in the drawer and chuck up a 1/4" high speed bit. Eyeball the solder joint for its location in the bottom of the hole, aim your drill bit for it and start drilling. Push gently! After you have drilled a small dimple, take a look to make sure that you are drilling at the right spot. If not, angle slightly to correct and drill the fence off from the lever. Frequently, the fence will fall off before drilling all the way through the lever.

Photograph five shows a lever that has been drilled. The 1/4" drill bit is considerably larger than the soldered post of the fence, which leaves a lot of room for mis-drilling on the exact location of the solder joint.

What happens now? If the fence is removed, the lever is now free to fall into the gate of the drive cam. It is the same as if the wheel gates were

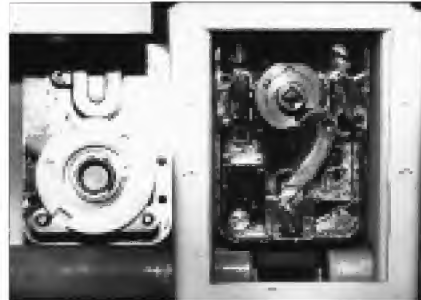

10. The opened lock. A drilled hole can be seen through the lock case and in the end of the lever.



7. Two screws hold the drawer to the guide.



8. Over sized curved shims are drawer spacers.

aligned under the fence. In our case, you would now rotate the dial spindle to the right. The nose of the lever will drop into the drive cam gate and retract the lock bolt. Push down on the drawer handle, and your security cabinet will look like photograph six! The elapsed time from pulling off the dial to opening the drawer (with tempered hard plate) shouldn't be over 20 minutes.

If the precise drilling location of the fence makes you a little nervous, there is an alternative method. The "X" marked in photograph four is an open area just above the lever. Without a Mosler template, plotting this location

Continued on page 14



11. The formed hard plate lock containment box.

Continued from page 12



12. The box has mounting posts for the combination lock.

would be at a dial reading of 60, and measured 1-1/2" from the dial center.

It will require a 90° viewing scope to use this drill location. A scope will allow you to see the wheels and align the gates under the fence to open the lock. The only disadvantage to making this your primary drill location — you can't solve any lock malfunctions through the scope hole.

Now that the drawer is unlocked and open, the repair can begin. To remove the drawer from the cabinet, there is a screw on each side of the

drawer. (See photograph 7.) Remove the two screws and lift the drawer up slightly (it's heavy) and pull it out of the guide rail.

While we are looking at this photograph, notice the knife shaped bar at the top of the drawer. This is the detent for the locking bolts. When you push the handle down, the bolts are retracted. The two bolts stay retracted until the drawer is closed. When you close the drawer, the detent bar rides up on a pin and releases the bolts. The locking bolts are spring loaded to push them out to their locked position. If you need to run the combination with the drawer standing open, lift up on the detent arm and the locking bolt will spring out.

After removing the drawer from the cabinet, you may find extra pieces laying on the floor. If they look like an over sized curved shim with a slot down the middle they belong in the cabinet. (See photograph 8.) On the end of the drawer guide rail you will find a rectangular tab sticking up. Those curved shims fit over the tabs. The shims act as spacers and

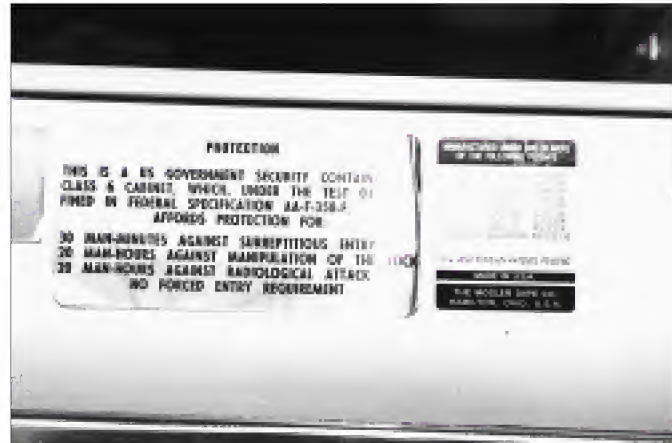

13. The information label will be found on the side of the drawer locked by the combination lock.

help level or square the drawer in the frame.

Remove the two screws from the inside drawer cover plate and slide it upward to remove. (See photograph 9.) You will now see the hardened steel box containing the combination lock. Slide the piece of hard plate up and out of the box. Directly behind the first piece is a second, smaller piece of hard plate. Tip this plate outward and remove. The lock case is now fully exposed. Remove the two lock cover screws and you are inside the lock. Reminder: the lock bolt must be in the extended position to remove the case cover.

Photograph 10 is a view of the Mosler lock and the back cover. If you look carefully, you can see the hole in the lock case and the drilled hole to removed the fence. The fence had dropped off and is laying in front of the bottom right mounting screw.

Photograph 11 shows a Mosler lock mounted into the hardened containment box used within the locking compartment of the safe drawer. Not shown are the two removable hard plate pieces. One piece sockets into the box directly behind the lock case cover. The second larger piece slides down in grooves to cover the entire lock area.

Photograph 12 is the containment box with the lock removed. The lock mounting posts and the spindle hole can be seen in the bottom of the box. The combination lock is protected from all sides by the hardened steel of the containment box.

Photograph 13 shows the label that will be attached to the side of the drawer that contains the combination lock. The information describes the container class and the requirements

ASP - Your Auto Service Center for the World

[Click here for more information](#)



14. Some mounting screws must be removed with an impact driver.

of testing against entry. A second label, not shown, will show the container model, serial number and date of manufacture. If you do not repair the container back to G.S.A. specifications, or do not install an X-07 lock, these labels and the label on the drawer face must be removed. The container can still be used, but for unclassified material only.

Getting the old Mosler lock easily out of the containment box, on occasions, can be a chore. The older style locks were held in place with 1/4"x20 Phillips head mounting screws. If the factory assembler was over generous with the liquid Loctite™, the screws can be a hassle to remove.

In Photograph 14 an impact driver is being used to loosen the resisting screws. If you don't have an impact tool, try heating the screw with a soldering gun. The heat will soften the binding material and allow the screw to be removed with a standard screw driver. The mounting screws of the later models were changed to an Allen head bolt and are much easier to remove.

Repairing of the hole must be done by electric welding. (See photograph 15.) The hole must be welded closed on both the outside of the drawer and inside the hardened containment box. Spot grind the completed weld down smooth and fill any irregularities with an auto body filler. (See photograph 16.)

What are the requirements for the repair of the container? The following is a direct quote from paragraph 5-310 of the 'Department of Defense Security Manual' - Section 3. Storage and storage equipment.



15. Repairs must be done with electric welding.

a. A (G.S.A.) Approved security container is considered to have been restored to its original state of security integrity, if:

1. All damaged or altered parts are replaced with manufacturers' replacement or identical cannibalized parts, or

2. When a container has been drilled to neutralize a lockout, the drilled hole is repaired with a tapered, case hardened steel rod with a diameter slightly larger than the hole and of such length that when driven into the hole, there shall remain at each end of the rod a shallow recess not less than 1/8" nor more than 3/16" deep to permit the acceptance of substantial welds and be welded on both the inside and outside surfaces. The outside of the repaired drawer head shall then be puttied, sanded and repainted in such a way that no visible evidence of its repair remains.

3. Approved security containers that have been drilled or repaired in manner other than as described above, shall not be considered to have been restored to their original integrity. The Test Certification Label on the inside of the locking drawer and "General Services Administration approved Security Container" label on the outside of the top drawer shall be removed from such containers.

The above is the guide line for correctly repairing the old style, black labeled G.S.A. containers when installing the new Mas Hamilton X-07 lock. The repairs must be approved by a G.S.A. inspector.

As mentioned earlier, no matter if the repair meets all specification, only a Mas Hamilton lock will restore the



16. Grind the repair area smooth and putty before painting.

container back to its original security requirements. If the original lock, a Mosler MR302 is installed, or if a 8400 and 8500 series S&G lock is installed, the container cannot be used to store classified materials.

A note pertaining to the replacement of a Mosler with a S&G lock. The Mosler lock bolt retracts flush with the lock case. The S&G does not. The end of the S&G lock bolt must be shaved off (1/16") to allow clearance for the locking bolts to pass.

The only thing that you will need to complete the repairs is paint to match the drawer. Mosler sells small spray cans of touch up paint and you should be able to pick this up from your local dealer.

If the area around the repair is textured, the smooth sanded area of the repair will be obvious. Mask off the area and spray with an automotive under-hood sealing paint. It will leave a rough dimpled finish. When it has dried, repaint with the touch up paint from Mosler. If you need just a little texture, spray the area heavy with the Mosler paint. As it just becomes tacky, dab the end of a brush into the paint. This will cause a light dimple, textured effect.

You should make up a form or a letter stating how the repairs were made. Even a copy of the above requirements on your letterhead, and a statement that the repairs met those conditions, would probably satisfy the G.S.A. Inspector.

I hope that this article will become a part of your safe opening notebook, and has given you insight and confidence to tackle a G.S.A. lockout.



NEWSMAKERS

New Products and Industry News

1995 Framon Depth & Space Manual

Framon Manufacturing Company, Inc., is proud to release the 1995 Depth & Space Manual. The book uses a new format for 1995, which includes progressive spacings for each chart. Spacing block reference



numbers are also included on each chart. The previous foreign and domestic sections have been combined into a single alphabetical listing. The 1995 edition contains information on all of the 1995 automobiles, including the GM 10 cut, Kia Sephia, and Ford Aspire.

**For FREE Information
Circle 336 on Rapid Reply**

DynaLock 5025 Series

DynaLock Corp. introduces its new 5025 Series Mini-Power Supply.

The economical 5025 power supply features a 1 amp regulated, field selectable, 12 or 24 VDC constant



output with fused primary and secondary circuits.

Other standard features include built-in battery charging circuit and NC contacts for fire alarm tie-in. Keylock Cover, Power Cord and Anti-tamper options are also available.

**For FREE Information
Circle 337 on Rapid Reply**

Horizon System By Sentex

Sentex Systems, which developed the first electronic directory system in 1988, is now offering the Horizon System, a low cost electronic directory telephone entry which is truly affordable for any size building.



The Horizon combines all the basic telephone and code entry functions found in Sentex's popular Vista systems with a large two line, high contrast LCD electronic directory and a new black metal keypad that is recessed into the faceplate and sidelit for easy night viewing. Despite the addition of the electronic directory and the sidelit keypad, the Horizon is priced competitively with systems which use typed directories.

**For FREE Information
Circle 338 on Rapid Reply**

Safe-N-Sekure New Home Wall Safe

Se-Kure Controls, Inc. brings added security to the home with the Safe-N-Sekure™ wall Safe. Designed for home security, the Safe-N-Sekure gives homeowners and apartment dwellers needed theft protection for their valuables.



Featuring 435 cubic inches of storage space, the Safe-N-Sekure wall safe is an ideal place to store any household valuables such as cash, jewelry, documents, firearms, and medication. It is easy to install and simple to remove, making it ideal for people who move frequently.

The safe features a recessed dead bolt combination lock and a double reinforced heavy gauge steel door to prevent tampering. It has generous 12-1/4" opening to ease storage retrieval, and a plush green felt lining further protects valuables inside. Because it is located inside a wall, the Safe-N-Sekure wall safe can be hidden by pictures, mirrors, and other wall hangings.

**For FREE Information
Circle 339 on Rapid Reply**

Gil-Ray's New Cutter Wheels

Gil-Ray Tools Inc., best known for their mail in sharpening service for dull



key machine cutter wheels has recently designed a new wheel to replace the standard quality cutters for Borkey® & Rytan® key duplicating machines. The new GRP-R & GRP-B cutters are made of premium CPM® M4 High Speed Steel, and feature a deeper tooth design and precision ground teeth, for longer service and accurate key duplicating. CPM® M4 is known to last up to three times longer between sharpenings than conventional M2 HSS cutters.

**For FREE Information
Circle 340 on Rapid Reply**

The Turtle Shackle Guard

The Turtle shackle guard is a new and very simple approach to protecting the shackle of most padlocks from attack by bolt cutters. The 10 gauge steel and the roof top design not only

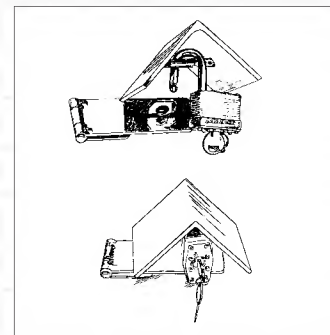

prevent the jaw of the bolt cutters from reaching the shackle, but also makes the padlock it protects, more cumbersome to pick or drill. The Turtle can enhance security for those customers who want maximum protection where padlocks are the only alternative. Display one on a good hasp on your display board, suggest it to customers who already have padlocks, with high security needs. And don't forget to stick your label on it for repeat sales.

**For FREE Information
Circle 341 on Rapid Reply**

SDC 101 Exit Check

The SDC 101 Exit Check is the most advanced Delayed Egress magnetic lock available today, featuring a digital count down display and verbal exit instructions. The Exit Check is completely self contained and activation is accomplished without power transfer or wiring to a panic device, and may be



used with existing mechanical exit devices.

Fire alarm release, field selectable egress delay, nuisance delay, authorized access time delay, and built in reset key switch are standard.

**For FREE Information
Circle 342 on Rapid Reply**

L & S Security Product's New Lock/Switch Mount

L & S Security Products has received a U.S. patent

for its combination lock and switch mount. The mount includes a face plate provided with an aperture in which a push button switch or a key operated switch may be located. A support bracket is located on the rear face of the face plate being formed as one piece with the plate and is provided with holes in which push button switches may be mounted.

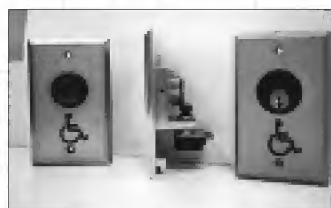

L & S Security key switches can be used with standard mortise cylinders (not included) and can be used indoors or outdoors to activate lights, gates, power doors, electro-magnets etc.

**For FREE Information
Circle 343 on Rapid Reply**

New National Cabinet Locks

National Cabinet Lock offers a newly expanded line of pin tumbler locks for higher-security protection of coin-operated machines, cash drawers and cabinets.



First is a tubular cam lock model for drawers or doors, as well, and may be used with lipped/overlay or flush construction. The flexafunction™ design feature enables the locksmith to assemble the lock with the right cam configuration to suit widely diverse needs.

Another higher-security lock is a 7-pin tumbler tubular

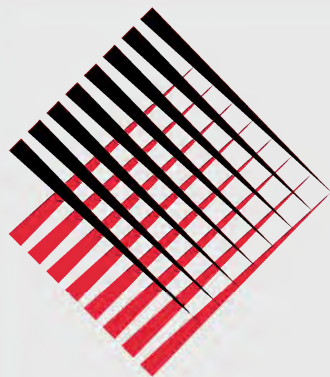

STRATATEC™

It's your reputation.

Trust the original.

[Click here for more information](#)

pop-out lock for vending machines. This lock is used in pop-out handles accommodating 3/4" dia. cylinders.

Each lock is supplied with two keys, spur washer for wood, mounting nut, two stop washers and two cams, double-punched for door and drawer applications.

**For FREE Information
Circle 344 on Rapid Reply**

Mnemonics, Inc. Video Surveillance Software

MNEMONICS, INC. introduced a new software product called VIDEO WATCHDOG™.

VIDEO WATCHDOG enables PC users to perform real time unattended monitoring of CCTV setups for border or perimeter intrusion. It provides event image storage to the PC disk and eliminates the need for time lapse recorders. Motion detection is performed by a sophisti-

cated algorithm that adapts to a wide range of background lighting conditions. A simple interface allows the user to identify up to 16 individual borders for intrusion detection with adjustable sensitivity control to filter out small objects.

**For FREE Information
Circle 345 on Rapid Reply**

New Draw Latch By Hartwell Commercial

Hartwell® Commercial introduces a new Adjustable Draw Latch. The H3601 is a positive, over-center latch, ideal for a wide variety of applications from hoppers to containers. The threaded draw hook adjusts approxi-

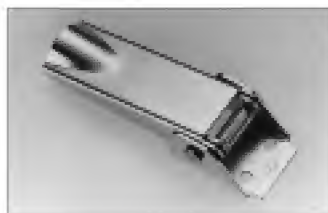

mately 1.98" to 2.44". The latch has a 600-lb. working load with an 800-lb. ultimate load.

Unique to the H3601 is an indentation for easy finger or tool release. The H3601 is value engineered to provide a quality latching component at a competitive price with a low installation cost. It is available made of zinc-plated steel or stainless steel and with or without a padlock eyelet.

**For FREE Information
Circle 346 on Rapid Reply**

Trine's New Digital Coded Receivers & Transmitter

Designed for residential or commercial use, Trine's new 017/018 series of digital coded receivers and transmitter operate on a range of 12 to 24 volts (AC/DC), and have over 6,500 security codes from which to choose.

The units reduce the amount of old-fashioned



hardwiring, while providing a transmitting radius of up to 150' from the receiver. Receivers and transmitters are ideal for low-voltage devices such as electric strikes, locks and bolts, electro magnets and garage doors. One receiver features a built-in 5 to 45 second time delay, and both have open and closed contacts rated at 3 amps.

Powered by a powerful, 12-volt battery, the transmitter can be clipped onto a belt, key ring, or hidden in a pocket or purse. Units come in an all white, contemporary design and receivers include provision for wall mounting.

**For FREE Information
Circle 347 on Rapid Reply**



medeco®
HIGH SECURITY LOCKS

**The market leader
in locking systems for security,
safety, and control.**

[Click here for more information](#)

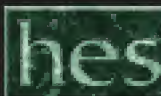

GENERAL SECURITY

CORBIN RUSSWIN EMHART HIGH SECURITY

Test Article #79

by Giles Kalvelage

Corbin Russwin's answer to high security cylinders is the Emhart High Security cylinder. (See illustration 1.) This cylinder can be identified by the name "Emhart" stamped onto the face of the plug. (See photograph 2.) Emhart High Security Cylinders are available in a variety of styles, Mortise, Rim, Key in Knob, and Interchangeable Core (Corbin Russwin style IC). The Emhart High Security cylinder utilizes six pin chambers with interlocking top, bottom, and master pins.

Each pin segment interlocks with the others in its chamber and is released by a twisting action caused by the bottom pin pressing against an angled slope of the key cut. When the key with the proper depths and angles is inserted into the plug, the pins line up at the shear line, the tumblers twist to the proper direction and allow the bottom, master or top pin to release and the plug to turn in the cylinder. If the improper key is inserted into the plug, or if the plug is manipulated, the pins will not rotate properly and will

offer increased resistance to turning. (See illustration 3.)

While the pin and plug design increase the security of the cylinder against picking attempts, drill resistant pins located behind the face of the plug and a drill resistant disc loaded behind the face of the shell provide for increased resistance against drilling the shear line. (See photograph 4.)

The keyblank and pin design not only offer resistance against picking,

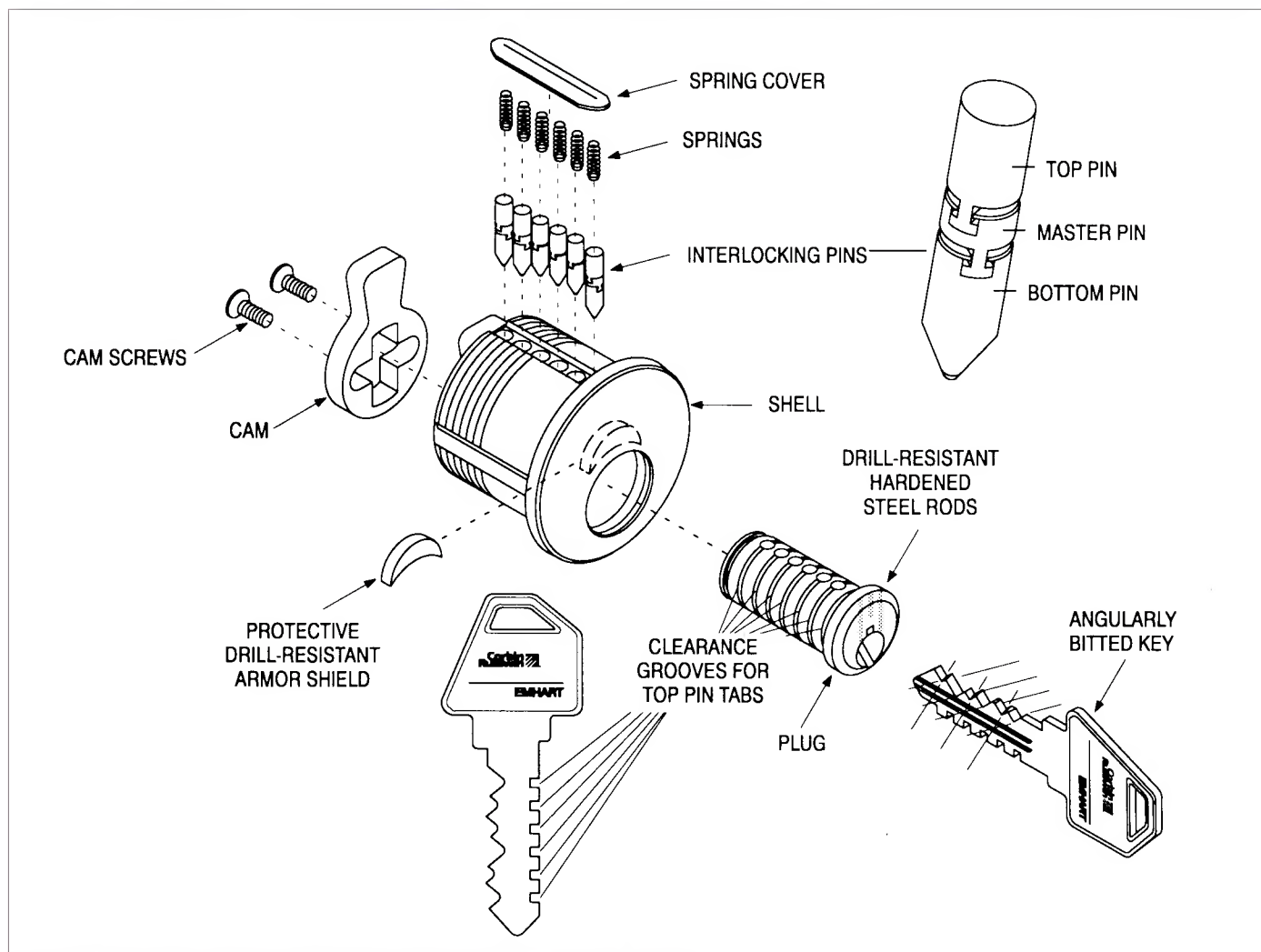

1. Exploded view of the Corbin Russwin High Security cylinder.



2. The Corbin Russwin High Security cylinder is identified by the name "Emhart" on the face of the plug.

they also increase the resistance against unauthorized key duplication. Keys must be cut on key cutting equipment which will allow for 20° angled - or skewed - cuts on the keyblank. No cut on an Emhart High Security key will be perpendicular. (See photograph 5.) While many locksmiths have access to this equipment, few non-locksmith stores are so equipped.

On the bottom of the key blade, there are slotted cuts which not only increase the difficulty of key duplication, but mechanically allow for the interlocking "projecting T" of the

top (or master) pins to pass over the key when the plug is rotated more than 180 degrees. (See photographs 6 and 7.)

As if this were not enough, the design of the system allows compatibility of high security keys to be used with most modern conventional Corbin Russwin cylinders. This allows for greater convenience in masterkey projects where only certain areas are required to be high security. (Corbin X Class, Russwin 752, 852, 981, A Series and N Series keyways are older and not compatible with the Emhart High Security system.)

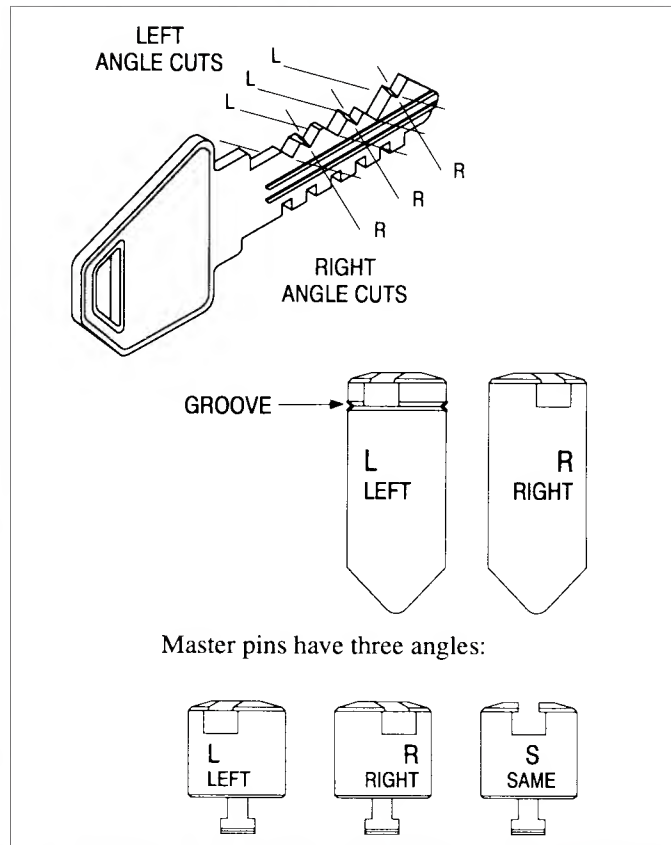

3. In order to operate, the pins in the lock must not only be cut with the correct depth, they must also have the correct angles.

If Emhart High Security cylinders are to be incorporated into a master key system with conventional Corbin Russwin cylinders, it is best to create the master key plan with high security keys and cylinders in mind. Emhart High Security keys must have a minimum depth of 2. Remember, the high security bottom pins have chiseled points and must skew 20° right or left. A number 1 cut will not provide the necessary key slope to skew a pin tumbler. Thus, only five depths are available on a high security

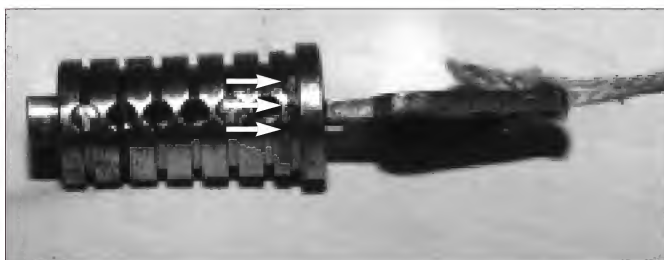

4. Three drill resistant pins in the plug and a drill resistant disc in the shell make drilling this cylinder difficult.



5. The Corbin Russwin HS key incorporates angled cuts.

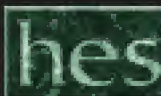

Continued from page 22

key, depths 2 through 6 - and restrictions within masterkey systems reduce the number of available depths.

Rules for Master Keying

1. No #1 depth for high security keys.
2. MACS is 4 for like angles and 3 for opposing angles.
3. Change keys must vary at least two steps or depths from the master key in a given chamber, but may vary only a single step or depth from other change keys.

4. When only high security pins are used, angles may be mixed within the same chamber.

5. Different angles cannot be of the same depth when the same depth is used in conventional cylinders within the system, or in the second or third chambers of high security interchangeable cores, or in



6. The grooves in the plug and the notches at the bottom of the key's blade are necessary to allow the interlocking tumblers to operate.

the last chamber of Brink and Blockout function cylinders. These cylinders use conventional pins in those chambers which allow either angle of high security keys to operate.

Pinning The Cylinder

All cylinders must be top loaded because the pin stack must be interconnected before insertion into the cylinder. If the cylinder to be serviced is already combined, simply remove the spring cover from the top of the cylinder as you would any other spring cover. If you are gentle, the same cover may be reformed and reused or just replace it with a new cover although new covers are inexpensive and easier to use. Dump all of the springs and tumblers from the cylinder.

*We have it all.
Quality, Value,
& Service.*

[Click here for more information](#)

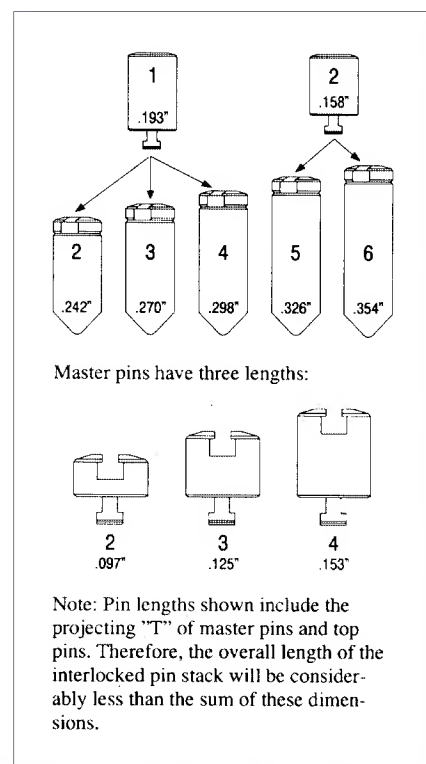

7. Notice the interlocking "T" shape of the bottom and master pins.

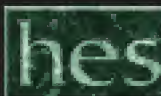

Continued from page 24



8. Factory cut keys come with a tag with the key code.

Select your combination. Factory cut keys come with a paper tag with the code. (See photograph 8.) Our key is 558 GWZ EZ. The three digits (558) refer to the keyblank, in this case, the L4 keyway. The letters, (GWZ EZ) refer to the bitting and angles of the key. This code is required if ordering cut keys from the factory. At one time, codes were available for sale on microfiche, but many codes were restricted and not available for sale. It would be advisable to decode your new key and keep your own records of the combination.

To maintain compatibility with conventional cylinders, depths on a High Security Key are approximately .006" deeper than the equivalent conventional depths. Conventional pins do not have chiseled points and will not seat at the root of a high

security key cut. Instead they seat on the slopes of the high security key cut.

To determine skew, hold the key bow to the left, cuts to the top. Skews to the left are denoted as "L", skews to the right are denoted as "R". (On factory bitting lists, "1" or "2" in parentheses or subscript after the bitting depth represented Left and Right skew respectively.) Thus the combination for 558 GWZ EZ would be 3L 2L 4L 3L 6L 2R on an L4 keyway. This is not a masterkeyed cylinder.

There are two lengths of top pins, #1 and #2. Number one top pins are used when bottom (and master) pins total 2, 3, or 4. Number two top pins are used when the bottom (and master) pins total 5 or 6.

Bottom pins are numbered 2 through 6 and are designated L and R.

Because change key cuts must be at least two increments away from the master key, only 3 lengths of master pins are available, 2, 3, and 4. Each length will have three available skews, L, R and S for Left, Right, and Straight. (See illustration 3.)



9. After interconnecting the pins, load them into the cylinder.



SRI and Steve Young are working together to bring you the best in locksmith tools and supplies.

[Click here for more information](#)

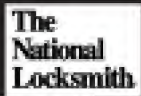
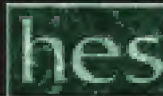

NATIONAL
AUTO LOCK SERVICE, INC.

National Auto Lock Service, Inc. offers a wide range of equipment and services for the Automotive Locksmith. From tools and hard to find key blanks to transponder programming, we can take the mystery out of car service. We accept credit card orders, and can ship COD. Contact us for the latest in automotive technology.

www.laserkey.com

Emhart High Security – Z and DH Class, System 70 Only

Applies to these keyways:	60	59A1	59B1	59C1	59D1	D1 thru D4 H1 thru H8 L1 thru L4	and restricted keyways not published for security reasons	ISO Code Case CX1 with code CX1103
	70	59A2	59B2	59C2	59D2			

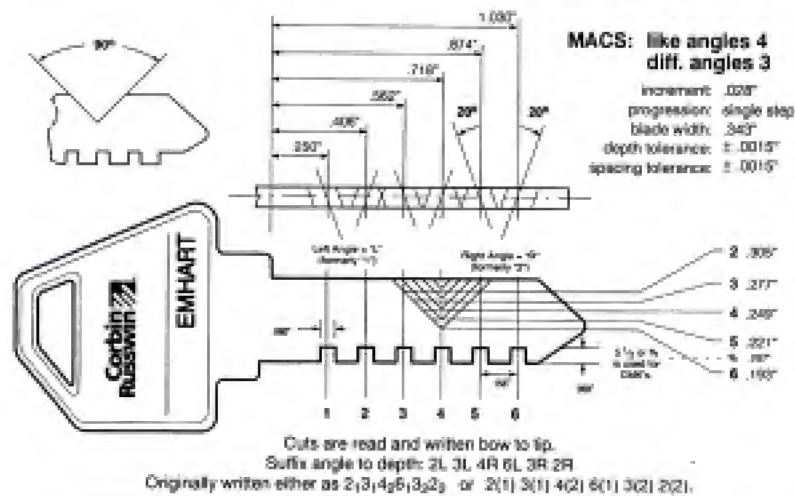

High Security Pins

The last 3 digits of the part number are the pin length, in thousandths of an inch, including the tab:

Bottom Pins			Master Pins		
New	Old	Order Pin #	New	Old	Order Pin #
2L	2 ₁	407T41-4242	2L	2 ₁	407T31-4097
2R	2 ₂	407T42-4242	2R	2 ₂	407T32-4097
3L	3 ₁	407T41-4270	2S	2 ₃	407T33-4097
3R	3 ₂	407T42-4270	3L	3 ₁	407T31-4125
4L	4 ₁	407T41-4298	3R	3 ₂	407T32-4125
4R	4 ₂	407T42-4298	3S	3 ₃	407T33-4125
5L	5 ₁	407T41-4326	4L	4 ₁	407T31-4153
5R	5 ₂	407T42-4326	4R	4 ₂	407T32-4153
6L	6 ₁	407T41-4354	4S	4 ₃	407T33-4153
6R	6 ₂	407T42-4354			

Top		Springs	
Size	Order Pin #	Type	Number
1	407T43-4193	Control Chambers	172F21-7
2	407T43-4156	All Others	603F20-7

Conventional Pins (1993 Consolidation)

For control chambers of high security IC and 6th chamber of Blockout and Brisk factors:

Bottom Pins	Build-Up Pins	Master Pins	IC Top Pins
2 .231"	-4 .030"	1 .028"	2 .198"
3 .267"	-3 .058"	2 .056"	3 .171"
4 .268"	-2 .087"	3 .084"	4 .142"
5 .316"	-1 .114"	4 .112"	5 .114"
6 .344"	0 .142"	5 .142"	6 .087"
	+1 .171"		
	+2 .198"		
	+3 .226"	Top pin for 6th chamber of Blockout and Brisk factors/cylinders: .171"	
	+4 .253"		

10. Corbin Russwin Emhart HS key system specifications.

To determine the angle of the bottom pin in a masterkeyed cylinder, the angle will be that of the key with the shallower cut. If the master and change key have different skews, the deeper cut determines the angle of the master pin. If both skews are the same, use the S master pin. (Factory notations are 1 for left, 2 for right, and 3 for straight or same instead of L, R, and S for master pins.)

To determine the angle of the pin you have, hold the pin so that the chisel point, if a bottom pin, or the "Projecting T", if a master pin, faces down and is centered. At the top of the pin, note the location of the T-Groove. If the T-Groove is towards the left, it is an L pin, towards the right, an R pin, and with master pins, the T-Groove centered is an S pin.

Interconnect the pin stacks and drop them into their respective chamber. (See photograph 9.) Load the springs, test the key, restake the spring cover and the cylinder has been rekeyed.

Depth And Space Information

Non restricted keyblanks may be ordered through your Corbin Russwin distributor. Restricted keyblanks require that a letter of authorization be submitted from the end user. (See Illustration 10.)

Original Corbin Russwin keyblanks are notably hard. When cutting, the factory recommends a drop of oil on the cutter to prolong cutter life and protective clothing to prevent damage to clothes from splattered oil.



AUTOMOTIVE SECURITY

THE 1994 JEEP CHEROKEE

Test Article #80

by Michael Hyde



1. The 1994 Jeep Cherokee.

2. The inside of the door showing linkage and tool placement.

This month we will take a detailed look at the 1994 Jeep Cherokee. (See photograph 1, above.) This vehicle was built by the Chrysler Corporation and thus uses the same

tumblers and keyways as other same year Chrysler cars and trucks. The Cherokee uses one Master key for all locks and a Valet key for the doors and ignition.



3. Remove the horn actuator assembly. Be careful not to damage the plastic insulating ring.

OPENING TECHNIQUES

The Cherokee can be opened by using a wedge and a horizontal slide linkage tool. While looking in the door there are two fabric sleeved rods. The top rod is for the lock. Use a slide lock tool to grasp the rod and unlock the door. (See photograph 2.)



IGNITION LOCK

To remove the ignition lock you must first disassemble the steering column. This steering column is made



4. Removing the steering wheel lock plate.

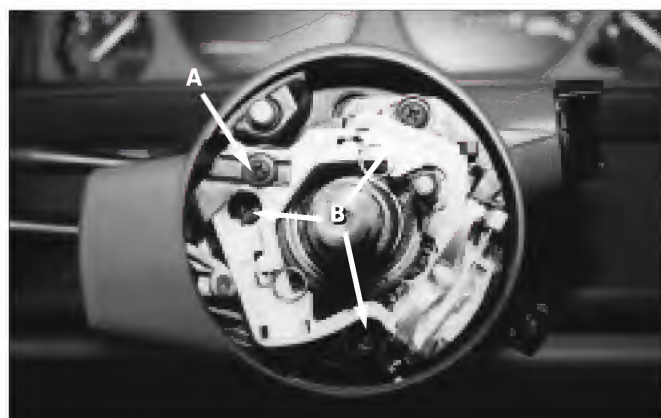

5. Remove the turn signal lever screw (A), and the three turn signal mounting screws (B).

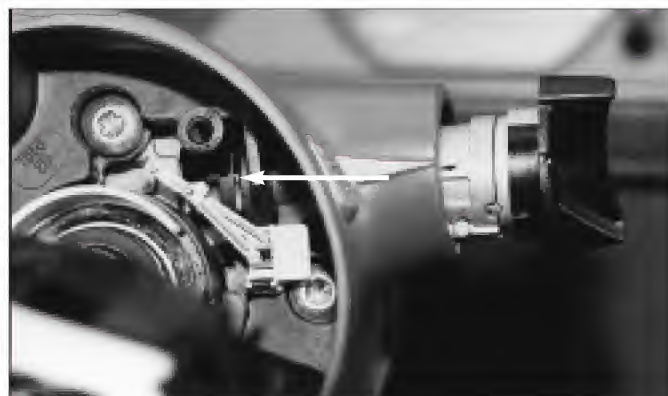

6. This small slot serves to hold the ignition lock retainer. Depress the retainer and slide the lock out of the column.



7. A disassembled ignition lock.

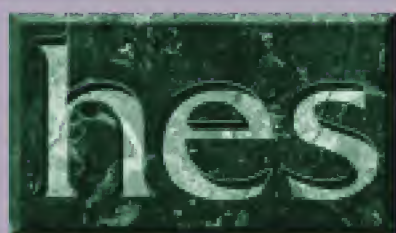

**The Innovation
You Expect,
with the
Flexibility
You Need!**

[Click here for more information](#)

by Saginaw and is similar to a General Motors column. With some minor variations servicing is almost identical. The hornpad on this unit is simply pressed on. Pull up on the pad to remove. Then remove the three screws that hold the horn actuator assembly to the wheel. This unit has a nylon insulating ring that is very easily broken. Be gentle in its removal and installation. (See photograph 3.)

Now remove the steering wheel lock nut. Use a steering wheel puller

to remove the steering wheel. Using a steering wheel lock plate compressor, compress the lock plate and remove the lock plate retaining ring. (See photograph 4.)

Now that the lock plate is out of the way you must remove the four screws that hold the plastic turn signal assembly in place. One screw holds the small connector to the turn signal arm and the other three hold the assembly to the steering column. (See photograph 5.)



**Choose S & G
Comptronic
electronic safe locks
for...security...
technology...
tradition.**

[Click here for more information](#)



8. The inside, driver's side door panel.

Once you have those removed, it is time to remove the hazard lights button found on the side of the column just below the ignition lock and gently pull assembly out of the column area.

Next, push in on the spring retainer that holds the lock cylinder in place. (See photograph 6.) This model does not use a retaining bolt, even though there is a place for it in the column. It is a true double-sided lock



9. Unlike older version that were held on with a clip, this window crank is simply pressed on.

with four tumblers on one side and three tumblers on the other side. The ignition lock contains all seven tumblers. (See photograph 7.)

DOOR LOCK

The door lock is separate from the door handle and is held in place with a standard horseshoe clip. To remove the lock, the inside door panel must be removed. (See photograph 8.) The arm rest is held in place by two screws, remove the arm rest. Next remove the window crank. The window crank snaps on and is not held on by any other retainer. Pull straight out on the handle to remove it. (See photograph 9.)

The next step is to remove the trim plate for the inside release and the lock/unlock knob. Once you remove the screw you can then slide the plate forward to unseat it. (See photograph 10.)

The lock cylinder is held in place by a horse-shoe style clip. Remove the clip and push out the cylinder. Because of the type of connector used to connect the linkage rod to the lock pawl it is easier to remove the 'E-Clip' on the lock pawl to remove the cylinder from the vehicle. (See photograph 11.) The door cylinder contains five tumblers, three on one side and two on the other side. The tumblers are cuts 3 through 7. (See photograph 12.)

REAR HATCH LOCK

The rear hatch lock is located on the center lower portion of the lift-up hatch. and is a push-in release type. (See photograph 13.) Open the hatch and gently pull back the plastic trim panel covering the inner hatch cavity. The trim panel is held in place by



SCHWAB CORP.

Fire protection for your vital records.

Free freight!!
No middle man!!

[Click here for more information](#)



10. Remove the inside release/lock assembly.

push-in type panel clips. (See photograph 14.)

After removing the horseshoe clip lock retainer, the lock simply slides out of the door. (See photograph 15.) It is easier to use a service package on the rear hatch lock than it is to try to recode the factory lock. The reason is that the factory lock's tailpiece is stamped in place and the large outer face cap is very difficult to try to reuse, as Briggs & Stratton does not sell it separately. (See photograph 16.)

The rear hatch cylinder contains five tumblers, three on one side and two on the other side. The tumblers are cuts 3 through 7.

GLOVE BOX LOCK

The glove box lock is held in place by a plastic C-clip. It is almost identical to the standard GM squeeze type. The plug comes out the front after you gently pry back the two tabs on the rear of the lock plug. (See



12. The disassembled door lock.

photograph 17.) The glove box lock contains tumblers on one side in positions 5 through 7.

MAKING FIRST KEY

Some ignition locks have a code on them. There are no codes located on any other lock.

Method #1

The easiest way to make a Master key to this vehicle is to use a tool called an EEZ READER by H.E. Mitchell Co. Using this tool, determine cuts 3 through 7 from the door cylinder and read cuts 1 and 2 in



11. Instead of separating the linkage rod from the lock pawl, it is easier to remove the C-clip from the back of the lock and remove the lock from the pawl.

the ignition for the complete key.

Method #2

Use Try-Out Keys.

Method #3

Impression Locks (I do not recommend this procedure as the tumblers are prone to breakage.)



13. The trunk lock.



14. To remove the trunk lock the inside rear gate panel must be removed.



15. The tailgate lock removed.

TUMBLER POSITIONS-	<u>1</u>	<u>2</u>	<u>3</u>	<u>4</u>	<u>5</u>	<u>6</u>	<u>7</u>	
Bow to Tip	x	x	x	x	x	x	x	Ignition
			x	x	x	x	x	Door
			x	x	x	x	x	Rear Hatch
				x	x	x		Glove Box & Seat Back.



17. The glove box lock plug is removed after pulling back the two retaining tabs and sliding the plug out the front of the lock.

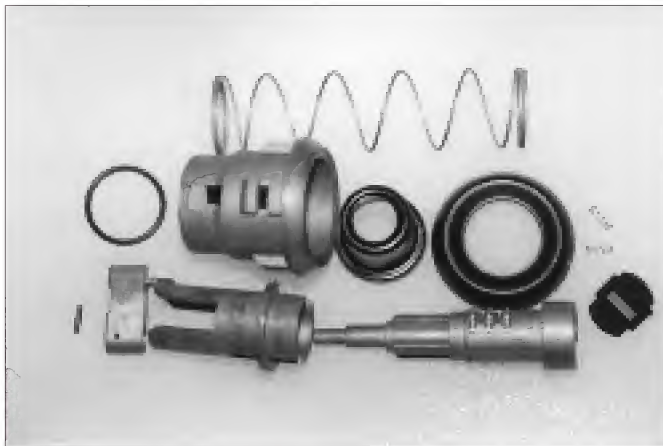

16. The tailgate lock is easier to replace than to rebuild. This service kit is available from Briggs & Stratton.

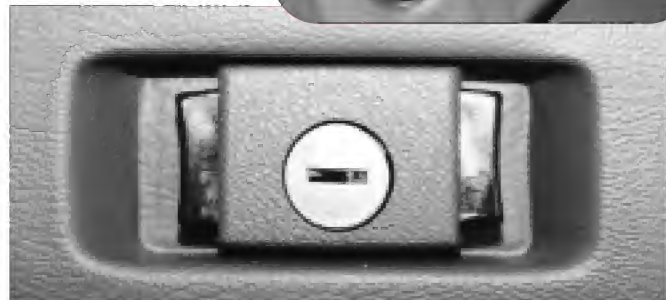

Method #4

Remove a door cylinder and decode it. Once you have those five cuts, then you can progression the remaining cuts for the ignition. The missing cuts needed for the ignition are the first two cuts.

Code Series: L0001-3580 (See the April and May 1994 issue of The National Locksmith.)
Key Blank: Ilco Y157 / Silca CY22
HPC 1200CM # CX60
MACS: 2
First Cut: .297

FRAM ON: Use Ford 5 pin clip and set for first cut @ .052"
Cut to Cut: .092"
Depths: 1=.340", 2=.315", 3=.290", 4=.265"



**LOCKMASTERS
SECURITY
MANAGEMENT**
TM

**Providing quality tools,
parts, and service for the
security professional.**

[Click here for more information](#)

**HPC has it all:
Key Machines,
Software, Books, Car
Openers, Pick Sets,
Tools, Door Guards,
and Key Cabinets**

[Click here for more information](#)

ELECTRONIC SECURITY

CCTV - JUST THE BEGINNING

Test Article #81

by Charles Stephenson

Selling simple solutions for serious security demands has always generated profitable careers for many entrepreneurs. The locksmith of yesteryear kept busy opening autos, duplicating keys and installing and/or servicing mechanical security devices. Meanwhile, the emerging "complicated hi-tech" security industry was being developed by new entrants into the traditional marketplace.

Too often locksmiths have been "locked out" of their rightful market due to complicated equipment, inadequate background, training, and/or legislation. Recent advances in closed circuit television (CCTV) technology will more easily allow the average locksmith to easily enter and regain a portion of that lost market.

During the next few months, you will be presented with a series of articles designed to increase your understanding of CCTV and give you the confidence to enter the new market with a new product that will appeal to thousands of prospective clients in your area. News reports of increasing crime in this country have forced the owners of homes and small businesses to realize their need for simple, reliable and affordable security. In conjunction with your mechanical security offerings, you can fill that need with CCTV systems. The opportunity awaits you!

Before anything else, however, let's start with a basic glossary of the terminology and jargon that we find in CCTV work. While the following may not make for exciting reading, remember that it is to be used as training material. Without knowing what the language means, understanding the coming lessons on CCTV may make for even less

interesting reading. That's a sad statement considering the amount of money to be made in this field.

Entrepreneur A person who organizes and manages a business undertaking, assuming the risk for the sake of profit.

AGC Automatic Gain Control; boosts the gain of the video in low-light situations.

Aperture The adjustable lens opening which is used to control the amount of light that enters. The aperture is expressed in f-stops. Aperture and iris are interchangeable terms. See f or f-stop, and iris.

Audio Of or relating to the reproduction of sound; especially to the sound phase of a telecast as differentiated from the video portion.

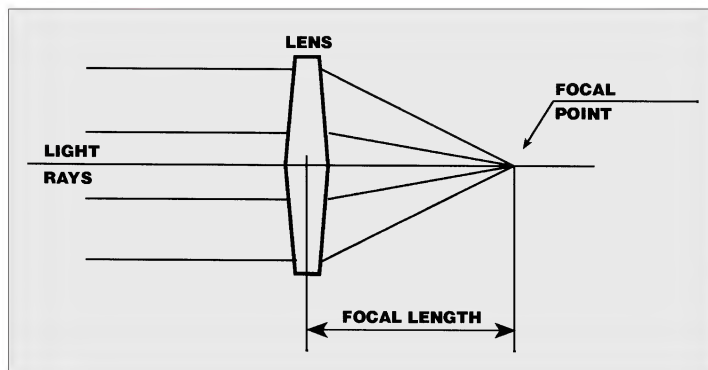

Automatic Iris A feature (normally of the lens) which controls the opening and closing of the aperture in order to compensate for the changes in light.

Back Focal Length The distance between the center of the rear lens and the image plane (chip).

Back Focus A primary or "rough" focus attained by adjusting the back focus ring (lens mounting ring). This procedure adjusts the distance between the chip in the camera and

the rear of the lens.

BNC A type of coaxial cable connector which features a miniature bayonet-lock.

Burn An image which remains in a fixed position on the monitor screen or camera tube. The image remains after the monitor is off or has turned to a different scene. Also referred to as burned-in image and image burn.

Burned-In Image See Image.

Burst A sudden increase in signal strength. Also referred to as a burst signal or signal burst.

Burst Signal See Burst.

CCD Charge-Coupled Device; a CID (coupled) on another transfer disk of silicone to increase the speed and quality of image transfer.

CID Charge Injected Device; a matrix of electrodes on a silicon wafer that stores photo generated minority carriers in potential wells under each pair of electrodes. The electrodes are then charged with current. By removing the voltage on the electrodes, the charges are injected into the substrate and the current readout is proportional to the number of stored minority carriers.

CRT Cathode Ray Tube; a type of tube used in many of the CCTV monitors today which utilizes an electron beam "blasting" the screen with lines of electrons. The pixels then light up in relation to the transmitted signal from the camera (CCD or chip) and form an image.

Chip A single substrate on which all the active and passive circuit elements have been fabricated.

Chip Camera A video camera using a chip or CCD rather than a tube as its imager.

C-Mount The distance between the mechanical mounting surface and the image plane (chip face) of 17.526mm. NOTE: A C-mount lens will only fit a CS-mount through the use of an adapter.

CS-Mount The distance between the mechanical mount surface and the image plane (chip face) of 12.5mm. NOTE: A CS-mount lens will only fit a C-mount through the use of an adapter.

Coaxial Cable A round cable consisting of two conductors. The central signal conductor is covered with an insulating material which in turn is covered with an outer conductor. The outer conductor (shield) acts as a return path for current through the center conductor and prevents energy radiation from the cable. This outer shield also prevents external radiation from affecting the current in the center conductor. The cable is surrounded with a protective jacket.

Composite Video Signal Signal of various elements which control different aspects of the image (video,

synch, and blanking information). Most video monitors used with computers and communications terminals operate directly from the composite video signal.

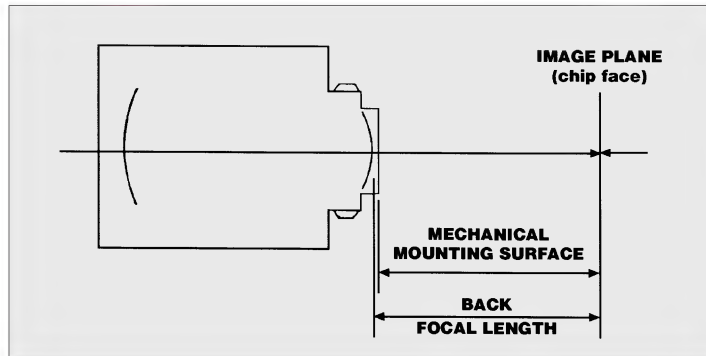

Connector A metal fitting (male or female) used to terminate a wire or cable. The BNC is most often used for professional hook-ups. Generally, VHS machines use the RCA phono type of connector.

Covert DC Restoration Concealed, hidden, disguised, or surreptitious. The re-establishment of the DC and low frequency components of a video signal which have been suppressed by AC transmission.

Depth Of Field The in-focus range of a lens. The distance between the first in focus object and the last in-focus object in a scene.

Dwell Time The time a switcher allows an image to be viewed before switching to another camera image. See switcher, and switching time.

Electronic Iris A feature built into the electronics of the camera to adjust for changing light. See Internal Iris.

Electronic Shutter A means of controlling the refresh rate of a CCD IC.

Event Recording Term used to describe the ability of a CCTV system to operate the VCR on demand rather than by pre-programmed time or continuous recording. See Time-Lapse Recording.

f or f Stop An indication of the brightness of a lens. The smaller the f number (f/1.2), the more light that is passed and the brighter the image. The larger the f number, the less light that is passed (f/3.5).

Major

MANUFACTURING, INC.

Every Installation
Is a Self-Portrait
Of the Person Who Did It.
Autograph Your Work with Excellence.

[Click here for more information](#)

WHAT IS A CHIP CAMERA?

Description and Operation

The newest generation of pick-up devices is not vacuum tubes at all, but large-scale integrated circuits that make use of a large number of microscopic "photo sites." Each photo site acts as the receiver of light energy. Here, charge carriers, electrons and holes, are liberated by the absorption of light energy. These carriers are held in the depletion zone of back-based diodes or under the depletion zone caused by the reverse bias applied to metal oxide interfaces on a P-type silicon substrate. The potential wells in which the charge carriers are trapped are tapped once each frame or, in some cases, once each field.

Resolution is determined by the number of photo sites on an area with a 3x4 aspect ratio. The area on the silicon substrate, or plate, is similar in size to that of the normal scanned area of 18mm pick-up tubes so that the lenses currently employed for those tubes may be used. Individual photo sites are very small and are arranged in horizontal rows and vertical columns. A total of 250,920 photo sites form that number of picture elements or "pixels." They are arranged in 510 vertical columns of 492 rows.

Storage Action

Like the vidicon, each tiny picture is sampled, or read out, only once each frame. In many cases, however, the photo site is taller than it is wide, as noted in the previous paragraph. In this instance, each site is sampled twice per frame, due to the interlaced raster, and the sample rate is 60 LLZ. This method yields a doubling of vertical resolution for a given number of photo sites. Thus, each site accumulates a charge packet of electrons that have been liberated by light falling on the site for the full 1/30th or 1/60th of a second. This storage factor accounts for the high sensitivity of CCD elements.



The CCD camera comes in various sizes and shapes. Its compact nature allows it to be stored in false thermostat and alarm device packages for covert recording.

Field Of View The width and height of the viewed image at a given focused distance from the lens. This is important when selecting a lens

Fixed Focus A lens that is prefocused to a predetermined distance (usually infinity).

Focal Length The distance between the principle point in the optical system and the focal point expressed in millimeters. The smaller the length, the wider the angle. The larger the length, the narrower the angle.

Focal Point The point at which a lens will focus parallel lines of incident.

Focal Range A measurement (mm) that describes the limits of a zoom lens. Example: 8-48mm or 10-100mm. See Zoom Lens.

Focus The convergence of light rays at a selected point. The process of bringing light rays to a minimum spot to create a sharply defined image.

Foot-Candle A unit of measurement equal to the amount of light one candle emits at the distance of one foot. Five foot-candles is the amount of light emitted by five candles at the distance of one foot. 1 FOOT CANDLE = 10 LUX.

Format The size of an image which the lens focuses onto the chip or imaging device. CCTV utilizes 1", 2/3", 1/2", and 1/3" formats or chips. A larger format lens will work with an equal or smaller format camera, but not vice versa.

Frame A television picture consisting of 525 horizontal lines (NTSC standard) or one frame of information made by a pair of video heads, each of which lays down one diagonal field on magnetic tape. Each head records one field containing 262.5 lines. Two fields make up one frame of 525 lines. The TV picture is transmitted at 30 frames (60 fields) per second.

GHz Giga Hertz. One billion cycles per second.

Ground Loop Transformer A passive ground loop correction device for coaxial systems. It nullifies the AC current that can occur in the video cable shield as a result of differing voltage potentials at either end of the shield. See Video Ground Loop.

Hz Hertz or cycles per second. The frequency of alternating current is 60 cycles per second (CPS).

Image Burn See Burn.

Image Lag See Image Retention.

Image Retention Unwanted lagging or trailing of previous images or pictures. This effect is usually caused by rapid movement of the subject, quick panning of the camera, or poor quality of the camera tube.

Image Sensor The metal oxide semiconductor chip used in place of the conventional image pickup tube in a video camera.

Impedance The resistance characteristics of any electronic circuit. VCRs and other units must have the same impedance level as the TV set (75 ohms and 300 ohms). impedance is measured in ohms. See Ohm.

Interference Signal interruption due to radio frequency (RFI), power surges, power spikes, and video ground loop.

Internal Iris A feature built into the electronic circuitry of a video camera to compensate for light changes. See Electronic Iris.

Iris Aperture the lens opening which adjusts to control the amount of light allowed to enter.

Line Amplifier A signal amplifier used to provide a clean and clear video signal when longer lengths of cable are needed.

Line Lock A form of synching. The camera does its internal synching based on the AC sine wave coming from the utility service.

Line Loop See Loop Circuit.

Line Phase An adjustment on a camera that allows for adjusting the point on the sine wave that the camera synchs to. Useful in large installations where cameras may be on different utility feeds.

Line Scan The movement of an electron beam across the screen of a cathode ray tube that creates an image.

Linear Integration Shutter See Electronic Shutter.

Lines Of Resolution See Resolution.

Loop Circuit A communication circuit that more than two parties share.

Looping (Line loop) operation performed over a communication line from an input unit at one terminal to output units at a remote terminal.

Loop-Through Jack A feature which allows several monitors and/or VCRs to be hooked up to a common signal source.

Lux A measurement of usable light when using video cameras. The lower the lux number, the less light needed for the camera to transmit a usable image. See Foot-Candle.

Manual Iris Feature on a lens which allows the user to adjust the amount of light that passes through the aperture.

Monitor A television set used for the display of composite video signal. The monitor may allow audio/video input by way of input jacks and is usually more costly due to superior circuitry and image quality.

Multiplex A device which simultaneously transmits two or more signals over a common medium (i.e., coaxial cable). A multiplex can also function in reverse, in which case it is called a demultiplexer.



ASP Covers the World of Auto Locks

[Click here for more information](#)

MONITORS: THE CATHODE RAY TUBE



A standard B&W monitor.

Black & White Monitors

The cathode ray tube is the heart of the TV set. It is a flask-shaped glass tube with an "electron gun" at its narrow end. The electron gun fires a stream of electrons (tiny electrical particles) at the TV screen. The screen is covered with a chemical, called phosphor, which glows when hit by the electron beam. The electron beam sweeps or "scans" rapidly back and forth across the screen, creating thousands of bright spots each second. These spots make up the complete TV picture.

If you look closely at a TV picture, you will see that it is either made up of a number of tiny lines or dots. At a viewing distance, the eye sees the lines or dots merged into a picture.

Color Monitors

The electron gun fires three beams of electrons, which correspond to the red, blue and green colors in the TV picture. The electron beams vary in intensity with the broadcast signal picked up by the antenna.

Two pairs of metal plates are electrically charged to deflect the electron beams to the left and right and up and down. This means that the beams can sweep across the TV screen to create the picture.

Between the plates and the screen is the shadow mask. This ensures that the correct beam hits the correct color dot or strip of phosphor. The red beam is directed at a red strip, the green at a green strip and the blue at a blue strip.

Ohm A measurement of the resistance opposing the flow of current. See impedance.

Pan & Tilt A motorized device which translates the direction of view of a camera. Pan refers to the horizontal direction of travel, while tilt refers to the vertical direction of travel.

Pixel The smallest picture element in a video image. The screen is divided into a rectangular grid of pixels of equal size and shape. The contrasting charges of the full grid of pixels form the image seen on the monitor screen.

Power Spikes Irregular strength of electrical current caused by switching devices on and/or off, such as electric motors, air conditioning, etc. Power spikes are also referred to as power surges and voltage surges.

Power Surge See power spikes.

Quad Display A device's ability to display four video images on one screen simultaneously with each image occupying one quarter of the screen. This feature is especially useful when recording or when needing to watch more than one scene at one time.

Quadraplex A system of videotape recording using four rotating heads.

RCA A reference to a type of connector used in audio/video transmission, common to VHS machines.

RF Radio frequency. A method of transmitting audio and video signals using the radio spectrum. See RFI and RF signal.

RFI Radio frequency interference or signal interference due to radio frequency.

RF Modulator A device designed to combine separate audio and video signals from VCRs, video cameras, and other sources into an RF signal which can then be played through a TV set. This device is common to internal circuits of a standard VCR and allows the TV to display recorded information being played back.

RF Signal See RF.

RJ-11-E A six-pin connector (similar to the type used with telephones) which connects video, audio, alarm and power circuits between cameras, monitors and other units. This type of connector and the associated cable is used by "kit" systems and eliminates the need for separate power cables, coaxial cables, audio lines, etc.

Real Time Having to do with the actual time during which events take place. A common term used to describe a type of recording in surveillance systems. See Time-Lapse Recording.

Resolution The maximum number of lines on a screen in a distance equal to the height. A measure of ability to delineate picture detail. Resolution may be stated in terms of modulation transfer function, spot diameter, line width, or raster lines.

Scan Line See Line Scan.

Sequential Switcher See Switcher.

Shutter A device used for opening and closing the aperture of a lens in a camera.

Signal Burst See Burst.

Slave Monitor A monitor with audio and video display features only;

Continued from page 42

used for viewing signals transmitted from a master unit.

Surveillance Control of premises for security purposes through alarm systems, CCTV or other monitoring methods.

Switcher A device or feature which allows images from more than one camera to be viewed in ascending order on the screen. Also referred to as a sequential switcher.

Switching Time The time allowed for viewing the subject of one camera before switching to the next camera in a sequential progression. This time is normally adjustable. See Dwell Time.

Synchronization The process of keeping the electron beam on the monitor screen in the same position as the scanning beam at the transmitter.

TDG Time-date generator. A feature of a VCR which displays the time and date on the frame for the benefit of recording events for use in prosecution of a crime. Also a feature of some monitors.

Time-Lapse A means of recording video information over long periods of time on a relatively short video tape. The video heads rotate at normal speed, but the tape moves much more slowly. Only periodic head scans are actually recorded, resulting in less information being recorded. See Real Time.

Transformer An electrical device which changes voltage in direct proportion to the ratio of the number of turns of its primary and secondary windings. Transformers may step-up or step-down (120 volts to 24 volts or 24 volts to 120 volts).

Video Ground Loop Signal interference appearing in the form of horizontal bars on the screen. The most common cause is the coaxial being run too close to power cables (i.e., florescent transformers), motors, generators, power converters, etc. See Ground Loop Transformer.

Video Printer A device capable of producing printed pictures from a video camera, VCR, or monitor.

Voltage Surge See Power Spikes.

YC Input "Y" video is the luminance or monochrome portion of a color video signal. The input is usually on a color monitor.

Zoom Lens A lens capable of changing its focal length from a smaller mm size (wider angle) to a larger mm size for a more narrow angle. See Focal Range.

I hope this glossary will prove to be a helpful resource. It will be handy to have on hand next month as we explore "Light, Lenses, and Lines of Definition."

The author is in field sales and CCTV development with Lockmasters, Inc at 606-885-6041. He would like to acknowledge and thank the Ultrak Group and Lockmasters' Art and Advertising department for their help and illustrations.



**To be a World Leader You Need Quality Products,
Innovative Technology and Strong Partners.**

[Click here for more information](#)

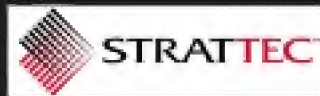

BEGINNER'S CORNER

Locking Up Pool Areas

In this city, there have been thirteen drownings in swimming pools in 1994. Of these, seven were children under five years old. The children are getting into pool areas where there is no protection. Due to this, the state and city officials are getting tough on regulations to prevent drowning.



by Eugene Gentry

In other parts of the country there are many people who have swimming pools at their residences, and there are also community pools at apartment complexes, town houses and condominiums. This provides an opportunity for the locksmith to suggest methods of securing pool areas.

Zoning laws concerning pools vary from city to city, and vary from private to community pools. These regulations do specify that the fences have to be designed so a child cannot squeeze between the bars or slats. The fence



1. Pools are required to have fences and locked gates.

also has to be a specified height, and have lock or latch on the gate that a child cannot reach or open. (See photograph 1.)

On a community pool, the main entry gate for the public, has to have a spring that closes the gate. The lock has to have a spring loaded latch so that it locks when someone enters or leaves. The lock also has to be double keyed, a key to enter and a key to leave. (See photograph 2.)

The maintenance gate, or gates can be padlocked, but they also must have a spring that keeps them closed. Keys to the maintenance gates are different from the main gate. (See photograph 3.)

A service call was made to a townhouse complex to rekey a main pool gate, maintenance gates and a pool equipment shed. Outsiders, former owners and former tenants were using the pool, and maintenance crews had been changed. The association wanted more control, and would issue new keys to people that lived at the complex.

The main gate lock was a Kwikset, double keyed, with a spring latch and secured with one way screws. The lock was rekeyed, and 150 duplicates made with DO NOT DUPLICATE stamped on them. The two side maintenance gates, and the pool house were locked with Master 5 padlocks, keyed alike. I suggested to the association that they use a rekeyable Master padlock so that it could be changed when necessary. They approved this so the padlocks were purchased and installed.

While taking care of the pool locks, the association said they had another

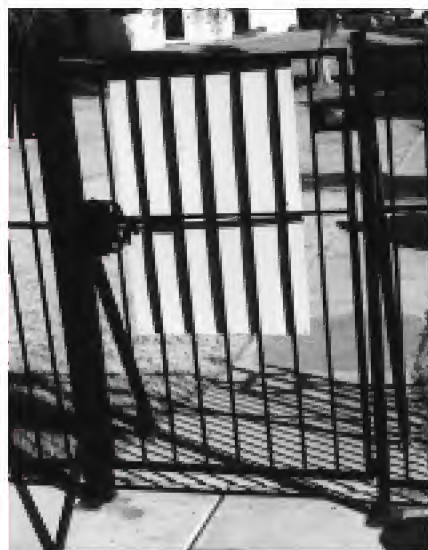

2. The entry gate must have a double cylinder lock and shut automatically.



3. Maintenance gates also must be locked and swing shut automatically.

Continued on page 114

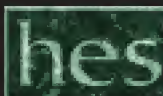

PUZZLES, PADLOCKS & PROFITS



Pursued by nearly all civilizations, throughout history, the padlock has become an integral part of most cultures.

by Jake Jakubowski

The year and name of the inventor of what we call the padlock is lost to antiquity. Most commonly, credit for its invention is given to the Romans. Another school of thought places the origins of the padlock with the Chinese. Still another theory gives both the Romans and the Chinese simultaneous credit for delivering the padlock to the world!

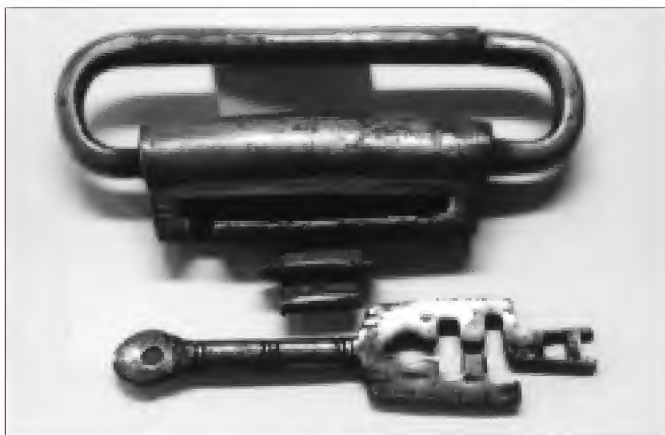

1. A handmade Iranian padlock from the 12th Century.

Although Linus Yale patented his first pin tumbler padlock in 1857, a fellow by the name of Andrews patented an Egyptian type pin tumbler valve lock that was used the same as a padlock' in 1840.

Subsequently, Bohannon (1860), Corbin (1865), Miller (1867), Lockwood (1875), Eagle (1880), Slaymaker (1888), Sargent (1894), Fraim, Junkunc, Harry Soref (Master Lock), and a dozen others patented their versions of padlocks. Ultimately, they all did for the padlock what Henry Ford did for the automobile ... they made it an American icon.

Today, padlocks come in all shapes, sizes and price ranges (See photograph 2.) You can buy an economy padlock, imported from the Orient, for a couple of dollars. Or, you can buy a heavy duty armored padlock that will retail for well over a hundred dollars! If you get bit by the padlock collector's bug, you might pay several thousand dollars for a really rare padlock!

The heavily armored padlock shown in photograph three is a Sargent & Greenleaf model 833A (This one built in 1983.), which was made for the U. S. military. If you have a customer that needs an armored padlock with more tough



2. Locks have and are made in all shapes and sizes. From the top is an Abus bit key, a Master Lock 230, and a King Lock with bit key.

Also lost, or at least shrouded, in the mists of history is the origin of the word padlock. The most frequently mentioned theory is that this type of lock was used to protect money and jewelry chests against thieves and highwaymen who were called pads in medieval times. Since the lock was used to lock out pads, it became known as a padlock. That sounds good to this ol' boy!

Regardless, the continued development of the padlock throughout

the centuries has been a challenge that has been pursued by the Hindus, Iranians, Pakistanis, Scandinavians, Germans, French, various Oriental cultures and, later, by the Yale's. (See photograph 1.)



The world's largest producer of automotive locks and keys.

[Click here for more information](#)

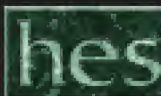

built into it than a John Deere tractor; you can order them. The commercial version of this S&G padlock sells for only \$561.91, retail!

Interestingly enough, the basic design (and application) of today's padlock isn't that much different from its predecessors of past centuries. (See illustration 4.) True, today's padlocks are made with better materials, higher security cylinders, more secure locking mechanisms and state-of-the-art manufacturing techniques. But, to put a twist on Shakespeare: A padlock by any other name ... will still a padlock be!

The best thing about today's padlocks is: They're a great, solid, year-round profit center for the savvy locksmith. I don't care whether you're a shop owner with ten trucks on the road, or an independent, one-person, one van, mobile operation. Padlocks should, and can, play a vital role in your inventory and sales and profit figures. This even in spite of competition from Sav-A-Ton Sam's \$2.98 special for imported-from-wherever padlocks.

Besides, there are wholesalers from which you can buy 1-1/4" imported, padlocks with an extruded brass casing, and a hardened (plated) steel shackle for about .90¢ each. Or, if you prefer, 1-1/2" padlocks for a buck and a quarter apiece! At those prices, you can compete with Sav-A-Ton Sam's \$2.98 special!

What kind of sales potential does the padlock have? Well, try this on for size: People, as in your everyday customers, that you already service; buy padlocks to secure gates, garages, gym lockers, gun cabinets, gumball machines gas mains and garbage cans. You'll find padlocks on flagpoles, fire hydrants, freezers and footlockers.



3. The S&G 833A made for the U.S. Military is made of all hardened steel and weighs 4-1/2 pounds.

Padlocks secure spare tires, electrical switch boxes and switching stations. You'll find them in nuclear power plants, on newspaper dispenser racks, at the North Pole and on your neighbor's tool shed. In other words, the padlock has become universal in its appeal and application as a viable security device.

Since padlocks secure everything from missile silos to soft-serve ice cream machines you can make money filling the seemingly

never-ending need for padlocks by selling them to individuals, businesses, industrial users, grocery stores and, even Uncle Sam - the same customers that you are already dealing with.

How do you sell high dollar, high profit padlocks in the face of import mania from home centers and price-break competition from every major retailer in the country?

One way is to find a supplier of low-cost, imported padlocks. It would pay to have a couple of those type locks on your service van for the customer that wants something to keep the kids out of the shed! It's a quick dollar, or two, worth of profit.

Or you can let your customer know that for their convenience, the locks they buy from you are re-keyable or can be keyed to their home, office, factory or store door key.

Another way is to personally guarantee the padlocks that you sell.

Still, another way, is to sell your customer on the idea of key control, and top-notch security, with Medeco, Abloy, or ASSA padlocks. Or, you can sell them an Abus Diskus, or a Schlage, or a Sargent & Greenleaf 8077.

Let them know that whatever special padlock requirements they have, you have a padlock that will satisfy those requirements. And, above all, let them know that if you don't have it on your truck or in stock, you can have it for them tomorrow That's what UPS Red Label was invented for - to help you get in a hurry what your customer wanted yesterday!

Primarily, you're going to sell your customer on service before, during and after the sale! And, in today's retail climate, genuine, customer oriented, service sells itself!

When it comes to selling your customer away from the economical imports, let your customer know how easily those locks can yield to the use of a stout screwdriver to pop the lock open. Show them why the better made more

medeco
HIGH SECURITY LOCKS

**Integrity.
Ingenuity....
security solutions.**

[Click here for more information](#)

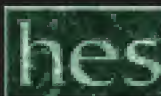

Visions Of Profits

Despite the variety of sizes, shapes and aesthetic features, padlocks throughout the centuries have changed very little with respect to application and function. From locking up ancient temples and burial grounds and protecting military sites, to protecting the contents of a backyard shed, manufacturers offer an array of functions, sizes, shapes and accessories to meet your customers' needs.



1. The Abus 24/70 Diskus (left) and the 20/70 Diskus padlocks; Great most any application where security and key control are needed.



2. American Lock Company's Series 2000 padlock and 825 hasp has become a standard for locking up service vehicle doors and other applications where a shackless lock is best. American also offers weather and vandal resistant locks with American keyways or that can accept other commercial keyway cylinders; Ideal protection for most residential and commercial customers.

3. Master Lock Company's commercial grade ProSeries locks are highly resistant to weather and vandalism. The new 6600 and 6700 series locks allow for keying into existing commercial keyways, while the 6400 and 6500 series locks accept IC cores from the major IC core manufacturers. Locks like these provide your customer with excellent protection while incorporating single or master key control.

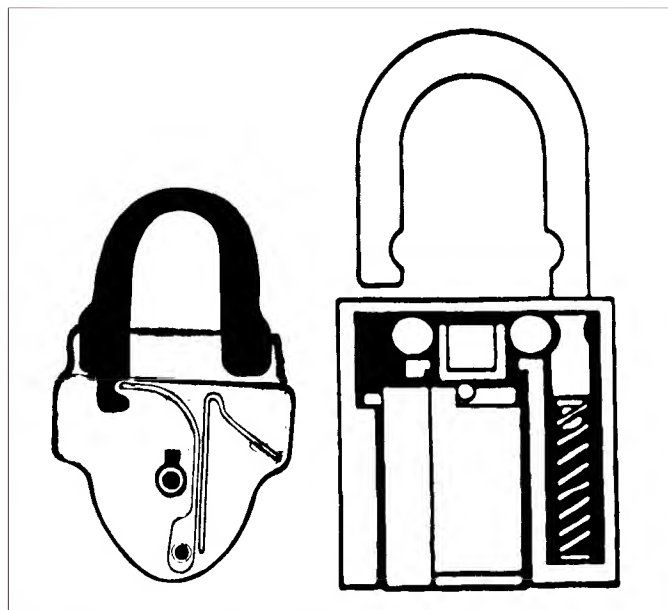

4. Through the years, padlock design and application have remained similar. On the left is a representational view of an ancient padlock. To the right, a more current padlock representation.

expensive padlocks are their better buy when security is their goal. Let your customer know that these heavy-duty, well made, padlocks will not succumb as easily to a determined attack by a hammer welding, or tire iron toting thug.

Continued on page 53

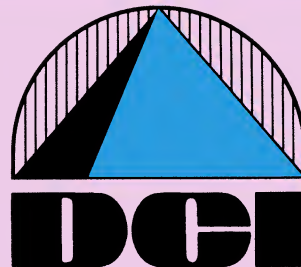

Don't panic! We have Security Exit Devices.

[Click here for more information](#)

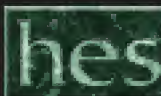

4. Schlage's recent entry into the padlock market, the PL series, offers you the ability to offer a weather and vandalism resistant lock that allows direct keying into any one of Schlage's keyways and keying systems. Your customers can now be

offered the type of protection they desire using Schlage orig-equip cylinders and keys, including the High Security Primus and Schlage IC Core system.



6. New to the market is Medeco's new System Series padlocks offering highly weather and vandal resistant locks that can be keyed into Medeco's high security key systems. These locks can offer your customers excellent protection plus the comfort of having high security key control.



5. While not designed for outdoor use, the S&G 8077 offers 30 minute protection against expert manipulation, 30 minute protection against radiographic attack and 10 minute protection against surreptitious attack. The primary feature of the 8077 is that it shows

immediate and visual evidence of having been forced, drilled, cut or burned. Not normally encountered by the locksmith, this lock can fill the high security specialty needs of some customers.



SRI and Tech Train Productions are the automotive specialists - your best source for automotive tools, manuals, and videos.

[Click here for more information](#)

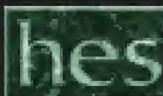

7. Reliable and inexpensive security can be offered to your customers with the LSDA line of padlock. Laminated or solid brass, LSDA offers padlocks that resist weather and corrosion and come in various sizes to suite most security requirements. LSDA rekeyable padlocks can be keyed to each other or to your customer's house.

9. CCL's Sesamee padlocks are not only keyless the customer can change the lock to one of 10,000 possible combinations. This means keys can't be lost or broke. Suited for outdoor use, the Sesamee padlock by CCL provides excellent padlock protection.

8. Offering two body sizes and seven shackle lengths (in three different materials), New Standard padlocks offer you customer excellent security. The New Standard 2000 series lock accepts conversion cylinders allowing keying into most commercial keying systems. The new NKR-CV convertible function padlock allows you to choose between a key retaining and non-key retaining function at the time the lock cylinder is installed.

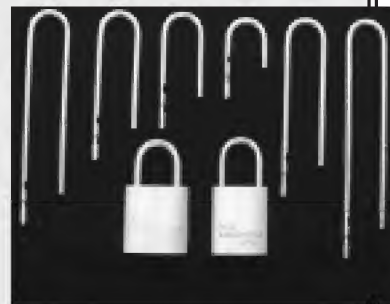

Continued from page 51

Don't be shy about telling your customer that unless the lock they buy has a shackle that is 7/16" or better thick, an ordinary set of bolt cutters can make short work of that lock. Show that customer how, and why the brands of locks you carry can withstand that type of attack.

Play up the security benefits of the padlocks that you sell. Sure they're more expensive than others that the customer can buy. But, the padlocks that you're selling are sold for, and able to deliver, what the customer needs most - security.

Talk to your customer about the use they want to put the padlock to. Then, help them select the lock that fills that need. For instance, if they have a well built tool shed with expensive tools and equipment in it, you might want to suggest a nice heavy duty lock that is weather resistant and/ or has a shackle guard.

Just remember this - the best made padlock in the world is only as secure as the manner in which the hasp is installed on the surfaces that it's attached to. A padlock, it's hasp, hinge and staple and mounting hardware all need to be considered in a balanced blend of product to give the greatest amount of durability and security.

Study their features and applications. Nothing's easier to sell than a product you know will deliver what you promise your customer it will ... or a product that you can really get enthused over! Padlocks qualify on both counts.

For more information on how to service, make keys and value collectible padlocks, you might wish to acquire Jack Robert's book, *Antique Padlocks*, published by this magazine (\$29.95).



The Innovation You Expect, with the Flexibility You Need!

[Click here for more information](#)

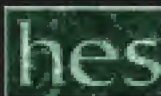

Cover
Feature

BIKES, MOTORCYCLES AND TRAILERS...

Accessory locks can offer your customers extra protection and you some extra profit.

Consumers are increasingly interested in protecting their possessions from theft. Sporting equipment such as boats, snowmobiles, jet skis, bikes, motorcycles or any vehicle stored on a trailer can be targets for theft because they are easily transportable.

Locksmiths can help customers prevent theft of their valuable equipment by offering a selection of lock products specifically designed to protect these items.



1. Specialty made locks offer bike owners a high degree of protection from bike theft. The more common brands include Kryptonite, using the Chicago tubular key, and Master Lock's U-Bar pictured above.

Bikes and Bike Locks

Mountain bikes and mountain-bike hybrids are the fastest selling bikes. As a result of their popularity, they have become prime targets of thieves.

Locksmiths can boost sales of bike locks by creating special displays that remind customers to secure their bikes with quality locks. Spring and fall periods are good times to sell these locks, so be prepared with a good supply of them.

There are many styles of bike locks offering different levels of security and convenience. Customers will look to you for assistance when selecting a lock.

"For maximum security, recommend steel U-bar locks," said Tom Smith, product manager for Master Lock Company. "Though U-bar locks are a bit more expensive, when you are protecting a \$700 to \$1,000 mountain bike, a \$30 lock is a wise investment," he said. Master Lock offers a \$1,000 theft protection guarantee with each U-bar lock. (See photograph 1.)

Still, many customers want the flexibility offered by cable and chain locks.

"When helping customers choose cable or chain locks, it's helpful to know who will be using the lock," said Smith.

"Resettable combination locks are ideal for young children because there are no keys to lose and the lock can be set to an easy-to-remember number. Young adults may prefer the security of keyed bike locks," he said.

For ease of use, many manufacturers offer bike locks that are attached to the cables. Those, such as the No. 8105-D and No. 8135-D by Master, include keyways with dust covers to prevent dirt, water and other contaminants from clogging or jamming the locks.

"Recommend that your customers buy the best protection they can afford. Quality locks can save the frustration and cost of replacing stolen bikes," said Smith.

Motorcycle Locks

Due to their size and value, motorcycles can present a tougher locking challenge than bicycles.

"We recommend motorcycle owners use heavy-duty chains and padlocks to protect their bikes," said Smith.

Some motorcycle manufacturers place a forked piece of metal on the bike that allows owners to secure the front tire to the frame. The tire is turned sharply to either the left or right (wherever the fork is placed) and secured with a



2. Jet skis, snowmobiles, boats and other recreational vehicles are offered a good degree of protection by using trailer locks.

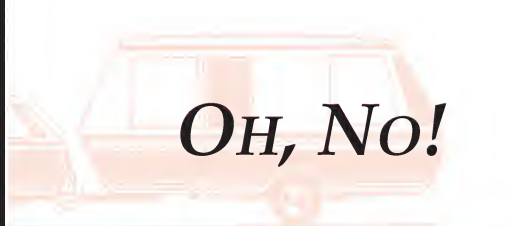
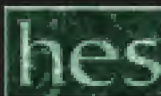

OH, No!

padlock. This makes it extremely difficult to roll the bike away.

Motorcycles without this type of security system can be protected with a heavy metal chain and padlock. Be sure to secure the motorcycle to an immovable object. "Chains are only as secure as their weakest link, so the thicker the links in the chain, the more difficult they are to penetrate," said Smith.

"We advise matching the width of the chain to the width of the padlock shackle, so the security level is compatible." He said.

"Another good option is to secure the motorcycle with a U-bar lock, providing there is adequate clearance with the U-bar," said Smith.

Trailer Locks

The popularity of jet skis, snowmobiles, boats and other recreational vehicles makes them targets for thieves. In addition, these vehicles are often stored on recreational or utility trailers, so they are easy to move. In fact, some thieves will drive up to trailers left in yards or driveways, hitch them to their vehicles and drive off.

Locks for trailers, such as Master Lock's trailer locks, are specifically designed to protect against tow-away theft of unhitched boat, snowmobile, travel and utility trailers.

Trailer locks from Master Lock fully enclose and block the trailer coupler so thieves cannot attach the trailer to their vehicle. The locks feature high-security pin-tumbler locking mechanisms. To resist rust and corrosion, the locks are coated with an epoxy acrylic finish. The locks also come in a variety of sizes to accommodate the different size hitches. (See photograph 2.)



Lockmasters has a 44 year history of training security professionals.

[Click here for more information](#)

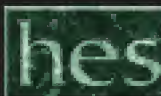

Cover Feature

SERVICING THE MEDECO SYSTEM SERIES PADLOCK



The Medeco System Series padlocks.

This new padlock offers optimum security and weather resistance, all under the Medeco key system.

The new Medeco System Series padlock incorporates a key-in-knob cylinder with a specially designed tailpiece or driver.

Photograph 1.



Medeco® has upgraded their high security padlocks with the introduction of a new line that can be master keyed with most existing door hardware systems. They are called Medeco® System Series padlocks.

Medeco's® new System Series padlock provides key control, pick resistance, weather resistance, protection against shackle cutting and ease of servicing. The padlocks use the same type of locking principle and key as Medeco's® other door hardware cylinders so Medeco's® existing door hardware pin kit can be used. There is no need to buy additional pin kits.

A new dedicated Medeco® cylinder, part #51-0600, which is similar to a key-in-knob type cylinder, is used in the System Series padlocks. The cylinder is different from other



by Gordon Malczewski

Medeco® key-in-knob cylinders in that the tailpiece or driver, that connects to the actuator, is an integral part of the end of the plug. (See photograph 1, bottom right.) Due to this special plug design, the cylinder will only fit in System Series padlocks. Cylinders are available in all Original & Biaxial® keyways.

Material & Design

The System Series padlock is available in either an indoor/ outdoor weather resistant design or with a shrouded shackle. (See photograph 1, top left.) The padlock body of both the indoor/ outdoor design and the shrouded shackle design are made of steel.

The shackles on both models are made out of a special boron alloy steel which provides a better through hardness to resist cutting, and provides better tensile strength to resist pulling attacks. The boron alloy also ensures that the shackle has an exceptional degree of ductility and is not brittle. Shackles can easily be replaced by removing the cylinder actuator and locking balls.



Continued from page 56



2. The broken down padlock.

The cylinder retainer is made out of hardened steel and has a rounded face which makes it difficult to drill. It fits over the cylinder bible chamber and is held in the padlock body with a steel Allen head screw. (See photograph 2.) The cylinder itself has four hardened steel rods in the plug face, a hardened steel ball bearing in the sidebar and hardened steel top pins to offer additional resistance against drilling. Medeco's® patented dual locking principal of elevating and rotating pins makes the padlock virtually pick proof. The Biaxial® keyways are protected by a utility patent that ensures strict key control.

The shrouded version has a specially designed shackle guard to offer greater resistance against bolt cutter attacks. Both models incorporate a Xenoy® thermoplastic cover over the body to protect the padlock from dirt and adverse weather conditions. The indoor/ outdoor design has a polyurethane material which seals around the shackle to prevent foreign material from entering the shackle holes. In addition, both padlock designs have special drainage channels to allow water to flow through the padlock and a dust cover to protect the keyway.

Tools

To service the padlock the following tools are recommended: (See photograph 3.)

1. 7/64" long reach Allen wrench
2. 1/8" Allen wrench
3. Small Phillips screwdriver
4. Small flat blade screwdriver



4. Drop the pin into the top of the chamber making sure the locator tab of the tumbler aligns with the locator slot of the pin chamber.



3. Tools needed for servicing the Medeco System Series padlock.

5. Hammer
6. Tweezers
7. Medeco® T-7185 holding fixture
8. Medeco® T-7093 staking tool

Note: The SS3 service block with adapter and staking tool from A-1 Mfg. Corp. may be used in place of items 7 & 8.

9. A plug follower with a .495" or .500" diameter is required if the locksmith does not want to remove the pin chamber cover.
10. Grease
11. Medeco® Key Lube

12. Medeco® K-1001 Original product door hardware pin kit which contains 30 of each of the bottom pins and top pins along with springs and set screws (does not contain any master pins). Or, Medeco® K-5001 Biaxial® product door hardware pin kit which contains 30 of each of the bottom pins, master pins and top pins along with springs and set screws.

Cylinder Removal

To remove the cylinder from the padlock:

1. Insert the key and unlock shackle.
2. Insert a 7/64" Allen wrench (long reach type works best) into the toe side of the shackle hole.
3. Turn the retaining screw counter clockwise until it is completely unscrewed.
4. The cylinder and cylinder retainer will then fall out of the bottom of the padlock.



5. Place the cover over the bible and stake.

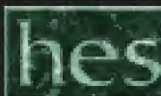

Rekeying Cylinder By Removing Pin Chamber Cover

1. Lift cylinder retainer off the top of bible chamber.
2. Place the cylinder in a Medeco® holding fixture (part #T-7185).
3. Gently pry off the pin chamber cover with a small flat blade screwdriver and then peel it back using a pair of needle nose pliers.
4. Remove the springs, take the cylinder out of the holding fixture and then turn the cylinder upside down and tap it on a padded surface to get the pins out. If the pins do not come out, insert an 1/8" Allen wrench into the pin chamber holes and twist it to get rid of any burrs that might exist from the staking operation.
5. Slide the cylinder back into the holding fixture and insert the key.

6. Select the bottom pin (they will contain a number for the length and a letter for the angle) and look for the locator tab on the pin. The locator tab is the tiny swaged projection on the top of the pin that limits the pin rotation.
7. Place the bottom pin over the pin chamber hole making sure the locator tab on the pin is aligned with the locator tab slot in the pin chamber hole before you drop the pin in place. Failure to orient the locator tab properly will result in a pin that is hung up on the top of the pin chamber hole. (See photograph 4.)

If the pin does not drop down, use a small common screwdriver to rotate the pin around till the locator tab aligns with the locator tab slot. A pointed tool can then be used to gently push the pin down into the pin chamber. Never push down on a pin unless you are sure the locator tab on the pin and locator tab slot in the pin chamber hole are aligned properly.

8. Turn the key after each pin is inserted to verify the proper pin was chosen. If you wait until all the pins are inserted before you check the operation of the key and the key doesn't work, you will be unable to determine which pin is incorrect.
9. Drop in a top pin (labeled a driver in the pin kit) and once again turn the key to verify that the proper pin was chosen. In a cylinder that is not master keyed, the top pin number is the same as the bottom pin number. For example, a 4Q bottom pin would be used with a number 4 driver (top pin). If a mushroom top pin is used, make sure the mushroom cap is pointing toward the bottom pin.
10. After all the bottom and top pins have been inserted, slowly withdraw the key and then insert the springs. With the key withdrawn the pins will be lower in the pin chambers and it will be easier to insert the spring and use the staking tool.

11. Place a pin chamber cover over the springs and then place the staking tool over the cover making sure the teeth line up on the space between the pin chamber holes. If the staking occurs over the pin chamber holes it will be difficult to remove the pins the next time the cylinder is rekeyed. (See photograph 5.)

12. Hit the staking tool with a hammer using several strikes and a moderate degree of force. The spring loaded detents will hold the cover in place as the teeth on the staking tool stake the bible chamber to hold the cover in place.

13. Lubricate the cylinder with Medeco® Key Lube.



6. Looking into the bottom of the Medeco® padlock after the shackle, ball bearings and actuator are in place.

Rekeying By Disassembling Cylinder

1. Remove the cam screws from back of cylinder plug using a small Phillips screwdriver.
2. Insert the key and turn it clockwise 90°.
3. Use a plug follower with a diameter of .495" or .500" to push the plug out of the shell. As the plug begins to move out of the shell place your index finger over the sidebar to keep from losing the tiny sidebar springs.
4. Turn the plug upside down and release your finger pressure on the sidebar to allow the pins to drop out of the plug. If 10 series bottom pins (which have a slot that is closed off at the bottom) have been used in the cylinder, the bottom pins will not drop out if there is pressure on the sidebar.
5. Remove the top pins from the shell. This is a very important step because the top pins must be graduated according to the bottom pin in order for the cylinder to operate consistently. Remember, you must change the top pins when you rekey a Medeco® cylinder!
6. Load the top pins in the shell using a plug follower and tweezers the same way you would load a conventional pin tumbler cylinder. In a Medeco® cylinder that is not master keyed, the top pin number is the same as the bottom pin number. For example if you use a 4Q bottom pin use a number 4 top pin (also called a driver). If a mushroom top pin is used make sure the mushroom cap is pointing toward the bottom pin.
7. With the key inserted and the sidebar held in place lightly (do not push in on the sidebar) begin loading the bottom pins. Make sure the locator tab on the pin is positioned directly over the locator tab slot in the pin

REPLACEMENT CYLINDERS FOR SYSTEM SERIES PADLOCKS		
51-0600 Dedicated Cylinder	20-20052	20-20071
20-200A1	20-20053	20-20072
20-200F1	20-20054	20-20073
20-200S1	20-20055	20-20074
20-20000	20-20058	20-20075
20-20049	20-20068	20-20097
20-20051	20-20070	

Chart Notes: If the replacement cylinder listed in the above chart has a tailpiece it must be removed and a cylinder extension, part #CP-100300, must be used. The System Series padlock cylinder 51-0600 is the only cylinder that does not need a separate cylinder extension since it is already machined into the end of the plug.

Table 7.

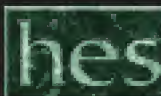

REPLACEMENT COMPONENT PARTS	
DESCRIPTION	PART NUMBER
Cylinder Extension (an adapter that connects the cylinder plug to the actuator)	CP-100300
Parts Package which includes: Actuator, Actuator Washer, Actuator Spring, 2 Locking Balls, Cylinder Retainer & Cylinder Retaining Screw	94-0062

Table 8.

chamber before you drop the pin down. Check to see that the top of the pin is flush with the shearline and then push inward on the sidebar to check for the proper angle of the pin.

8. Check to make sure the ball bearing on the sidebar is positioned toward the front of the plug, especially if you previously removed the sidebar from the plug.

9. After all the bottom pins have been inserted, push inward on the sidebar until it is completely flush with the plug and then push the plug into the shell. Turn the key to check for proper operation.

10. While holding the plug in, pull the key out and install the stop washer and screws. The stop washer screw holes will only line up in one direction, so, if the screw holes don't line up, flip the stop washer over.

11. Put a small amount of Loctite® #242 (removable blue colored threadlocker) on the stop washer screws, install screws and tighten until snug.

12. Lubricate the cylinder with Medeco® Key Lube.

Cylinder Installation

1. Place the cylinder retainer over the top of the bible chamber with the screw hole toward the back.

2. With the shackle locked and the key removed from the cylinder, drop the cylinder and cylinder retainer into the padlock body.

3. Insert the key and turn it to release the shackle. You will need to pull up on the shackle since the shackle is not spring loaded. This procedure will insure that the padlock is working properly before you insert the retaining screw.

4. Insert the retaining screw in the toe side of the shackle hole and tighten.

Actuator & Shackle Removal

1. Insert the key and unlock shackle.

2. Insert a 7/64" Allen wrench (long reach type works best) into the top of the toe side of the shackle hole.

3. Turn the retaining screw counter clockwise until

it is completely unscrewed.

4. The cylinder and cylinder retainer will then fall out of the bottom of the padlock

5. With the padlock held upright, tap the padlock body on a padded surface and the actuator and locking balls will fall out of the bottom of the padlock.

6. The shackle can then be pulled out.

Actuator & Shackle Installation

1. Slide the shackle into the padlock body.

2. Place the padlock upside down on the top of a partially opened vise so the shackle can extend downward and the padlock body will remain in a level position.

3. Place a small dab of grease on the locking balls and then drop them into the padlock body. The grease will lubricate the actuator and help hold the balls in place during the assembly process.

4. Hold the shackle fully closed and then push the locking balls toward the shackle until they are almost completely clear of the cylinder hole.

5. Look deep into the cylinder hole in the padlock body and find the oval shaped cut-out. It is located on the same side of the padlock as the Medeco® name. (See photograph 6.)

6. Align the hooked end of the actuator spring over the oval shaped cut-out and use tweezers or needle nose pliers to lower it into place.

7. Press on the actuator and twist it until it is fully seated. If the actuator doesn't appear to be fully seated remove the actuator and check to make sure the locking balls have not moved out of position.

8. The cylinder can now be loaded into the padlock.

Replacement Parts & Cylinders

A locksmith that has existing inventory can order the padlock body without a cylinder and use a variety of Medeco® key-in-knob cylinders simply by removing the tailpiece and inserting a special cylinder extension CP-100300. The cylinder replacement chart gives a complete listing of Medeco cylinders that can be used. (See table 7.) It is however, less expensive to purchase the padlock complete with a cylinder since the 51-0600 cylinder is less expensive than other Medeco key-in-knob cylinders.

Individual replacement component parts are also available from Medeco Distributors.

(See tables 8 and 9.)

The author is Training Dept. Mgr. at Medeco Security Locks. Contact Medeco at 703-380-5000 for any technical questions regarding the System Series padlock.

REPLACEMENT SHACKLE PART NUMBERS			
SHACKLE DIAMETER	SHACKLE CLEARANCE	PADLOCK STYLE	SHACKLE PART NUMBER
5/16"	1-1/8"	Indoor/Outdoor	CP-143530
5/16"	3/4"	Shrouded	CP-143520
7/16"	1-3/8"	Indoor/Outdoor	CP-141290
7/16"	1-1/2"	Shrouded	CP-141280

Table 9.



Cover
Feature

A NATIONAL LOCKSMITH PROFILE A NATIONAL LOCKSMITH PROFILE



WHO'S COOKIN' WITH PADLOCKS?



Tom Gallian, successful restaurateur, locksmith and padlock collector.

When provided with the opportunity, The National Locksmith Technical Editor, Jake Jakubowski took advantage of speaking with padlock collector, Tom Gallian.



Interview
by
Jake Jakubowski



1. Entering Tom's Museum of Antique Padlocks.

A NATIONAL LOCKSMITH PROFILE

A NATIONAL LOCKSMITH PROFILE

I met Tom Gallian about seven years ago in Raleigh, North Carolina. I initially saw his padlock collection when I took the first safe door I ever had to modernize to his shop and sought his help. Not only did he show me what to do and how to do it, he befriended me like he has numerous other locksmiths around the country.

After we finished the safe door modernization, Tom asked me if I'd like to see his padlock collection. I figured: "Why not?" Boy! Was I glad I said, "Yes!"

I don't know what I expected the first time I walked into Tom's Museum of Antique Locks. (See photograph 1.) What I got was a surprise. Although I didn't know it at the time, I walked into one of the most extensive, private padlock collections in the United States! (See photograph 2.)

Tom lays claim to the largest number of Eagle Padlock prototypes and greatest variety of Eagle padlocks in the world. In addition, he believes he has the world's largest Ellis padlock collection. And finally, but by no means the least, his collection boasts the most exclusive, one of a kind, collection of Yale locks in the hands of a private collector.

For the last couple of years, I've been bugging Tom to let me do an article on his collection and take some photographs to share with The National Locksmith readers. Here, finally, in an interview format, are the results of my importuning.



2. This is just a small sampling of the 7,000 plus locks in Tom's collection.

Tom, just to provide our readers a little background, I want to tell them that you were, and still are, a successful restaurateur as well as a successful locksmith, a very competent safe and vault technician and, obviously, a serious and dedicated padlock collector.

What prompted you to start collecting padlocks and keys?

For as long as I can remember, I have been curious about, and interested in, locks and safes. However, it wasn't until I became a locksmith that I started collecting padlocks.

NATIONAL
AUTO LOCK SERVICE, INC.

National Auto Lock Service, Inc. offers a wide range of equipment and services for the Automotive Locksmith. From tools and hard to find key blanks to transponder programming, we can take the mystery out of car service. We accept credit card orders, and can ship COD. Contact us for the latest in automotive technology.

www.laserkey.com

A NATIONAL LOCKSMITH PROFILE

A NATIONAL LOCKSMITH PROFILE

Do you remember the first piece that you collected? Do you still have it?

Yes! And, yes! When my grandfather died, I acquired the two Yale padlocks that you see here. (See photograph 3.) He used these locks to lock the doors of his blacksmith shop. These two padlocks became the basis of my collection.

You've been collecting now for 14 years. When you and I visited the old Slaymaker Padlock Factory in Lancaster, Pennsylvania last fall, you told me your collection had just passed the seven thousand mark. What is your latest acquisition?

These two logo locks from North Carolina's Fort Bragg Department of Public Works and Engineering. These are Best I-core locks, and while not antiques, they are unique collectibles because of their logos. (See photograph 4.)

Tom, I'm looking at an old promotional poster that Yale put out in 1925. You have actually covered each of the illustrations with the appropriate lock. But, tell me, do you have a particular favorite of all the locks you've collected? (See photograph 5.)

Actually, I have several favorites. The first is a Crabclaw, made personally by Linus Yale, Sr. in the early 1830's. Then, there is a prototype by Yale. And this is a prototype slider by J.C. Preston, a Yale employee, which he made before Yale was granted a patent on these padlocks.

Next is a Yale Slider with side panels that was made sometime in the mid-1800's and shows a patent date of 1857. Finally, here is a key for a Yale Quadplex pin tumbler safe lock and a key for an early Yale rim lock with a hold open feature. (See photograph 6.)

You see, Jake, it was locks like these that gave Yale their start in the U.S. lock making industry.

Looking around, I see Chinese gate locks, Hindu temple locks, Roman finger keys and Scandinavian jail house locks. What is the oldest padlock that you have and where did it originate?

Probably this one. (See photograph 7.) This lock was handmade in Iran sometime in the 12th Century. In the



3. These two Yale padlocks were used on the blacksmith shop of Tom's grandfather, and was the start of his collection.

My idea, they still make similar locks today. That makes it difficult to determine this type of lock's true age. You can see a similarity between this lock and Yale's sliders.

Tom, what is the most unusual padlock you have in your collection and what makes it so?

Actually, Jake, the most unusual piece that I have in my collection is not a padlock but a pair of handcuffs made by Elias Richarts of Sheppardstown, West Virginia about 1830. (See photograph 8.) Two things make these handcuffs unique.

First: as far as is known, this is the only pair of Elias Richarts handcuffs in a private collection.

And, second - A pair of Elias Richarts handcuffs were used to shackle John Brown when he was captured at Harper's Ferry, West Virginia by Union Troops led by Lt. Colonel Robert E. Lee, with J. E. B. Stuart as his second in command!

I've seen collections in size from just a dozen or two locks to those like your collection with thousands of padlocks. If a locksmith were interested in getting started as a collector, what advice would you give them?

I'd say the first step is to put aside any unusual lock that they come across. For instance, if a customer brings them an



4. These Best logo locks are made in limited quantity and are Tom's latest acquisition.



5. A 1925 Yale promotional poster that Tom has completely filled with the actual locks.

Continued from page 64

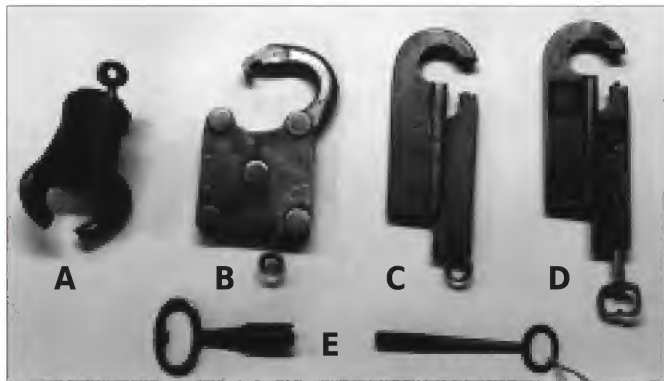

6. The Crabclaw (A), an early Yale prototype (B), a prototype slider by J.C. Preston (C), a production slider (D), and keys (E) for Yale Quadplex and rim lock.

old lock to have a key made, try to trade that lock for a new padlock, or try to buy it from them.

Also, they should keep their eyes open at swap meets, flea markets and yard sales for any locks that appear markedly different from the ordinary.

I've been with you on some of your forays when you're doing the flea markets looking for padlocks. I also know that there are a lot of antique locks offered for sale that aren't antiques. Can you tell a new collector how to keep from being burned?

Knowledge is the key to not getting burned and you often learn your most unforgettable lessons by getting burned. However, a good place for a beginner to start acquiring knowledge is with "The National Locksmith Guide to: Antique Padlocks by Jack Roberts." Another helpful publication is "The Padlock Collector" by Franklin M. Arnall.

Another excellent learning source are the regional padlock collector shows held around the country.

Photograph 9 shows two fraudulent locks and two bonafide locks. Tell us which set is which and you can win a copy of The National Locksmith Guide to: Antique Padlocks. Send us your answer by mail or through our new E-mail service. The first locksmith to answer correctly wins. Hints: The Skull and Crossbones on the left is made of brass, the one on the left is not. The Keen Kutter on the left uses a bit key and front rivets, the one on the right does not.



8. This may be the only pair of Elias Richarts shackles in a private U.S. collection.

A NATIONAL LOCKSMITH PROFILE



7. A handmade Iranian lock made in the 12th Century.

Not all of the locks you have are truly antiques. Yet, I know they are valuable as a collector's item. Can you tell my readers why a lock like this Eagle cut-away or this logo lock from Best are considered collectible? (See photograph 10.)

Manufacturers like Eagle usually made limited quantities of cut-aways which were used to illustrate how the lock functioned. Because these were made in such small quantities they are harder to find and, consequently, more valuable to a collector.

The same holds true for "logo" locks. They were usually produced in limited quantities and not readily available to the public. That scarcity makes them desirable collectibles

Tom, I really appreciate the time you've given my readers. Is there anything else that you would like to say in conclusion?



9. Which locks are genuine and which are "knockoffs?" Send us your answer by mail or through our new E-mail service. The first locksmith to answer correctly wins a copy of The National Locksmith Guide to: Antique Padlocks.

A NATIONAL LOCKSMITH PROFILE A NATIONAL LOCKSMITH PROFILE



10. The Eagle cut-away (left) and the Best logo lock are collectible because of their limited production.

Jake. The best advice I have to give any locksmith or collector, is to join their local and national associations. Not only can they take advantage of the educational opportunities offered by the associations, they can develop networks of people that share a common interest. And, they can share their knowledge with others in their group.

Author's Note: In addition to the books Tom mentioned, anyone who is seriously interested in collecting padlocks should subscribe to: The American Lock Collectors Association Newsletter, 36076 Grenada, LaVonia, MI 48154. If you are interested in buying or selling padlocks, contact Tom Gallian, P. O. Box 545, Dunn, NC. 28334. Or, you can fax your query to Tom at 910-892-2608.



**To be a World Leader
You Need Quality
Products, Innovative
Technology and
Strong Partners.**

[Click here for more information](#)



**Choose S & G
Comptronic
electronic safe
locks for...
security...
technology...
tradition.**

[Click here for more information](#)

UP IN

**Come with us as
The National Locksmith and
the Streamwood (Illinois) Fire
Department put some fire safes
to the test.**

1. (near right)
The willing volunteers, a
Sentry 3140 and a Meilink
251.

2. (center)
The place?
The Streamwood (Illinois)
Fire Department fire
tower!

3. (far right)
The volunteers are loaded
with the boss's goodies.



SMOKE!

by Tom Seroogy

It could be another segment of the Twilight Zone, or, maybe, Tales From The Dark Side. Those grossly revealing programs written from a cynic's eye. An expose of man's worst side (Or, cynically, his best).

And, despite our attempts to cover it, there lurks within the heart of every locksmith - a dark side. A side that challenges the norm, the accepted, and the sacred. If a lock says "Pick Proof," we try to pick it. If it says "Burglar Proof," we burgle it. If it says "Fire Proof," we burn it.

And, so, we did!

That's right. That primordial urge to challenge surfaced and we put a couple of fire proof safes to the test.

Now, it should be stated that we did not follow the procedures and testing methods used by Underwriter's Laboratories. (Then, again, what locksmith hellbent on destroying what claims "can't be destroyed" has respect for any standardized test?)

Instead, we asked for a couple of volunteers (safes) and set them on fire: No controls (except those employed for safety reasons), no gauges, no timers, no drop tests. Just a good ole fashion, outrageous, weenie roasting fire.

Our volunteers included the new Sentry 3140 and Meilink 251 fire safes. (See photograph 1.) Out to accomplish the mission was this writer, *The National Locksmith* Advertising Account Manager, Debbie Schertzing, and Technical Writer/Safe Expert, Dale Libby. To help in our little endeavor, the Streamwood (Illinois) Fire Department provided the place for the burning, a fire tower, and Fire Fighters Lt. Robert Bolanoski and Jim Dykstra. (See photograph 2.)

Knowing a test isn't a test unless there's a risk, we volunteered some valuables to go into the safe during the burn. Naturally those valuables belonged to publisher and our boss, Marc Goldberg. The items included a priceless issue of *The National Locksmith* magazine (aren't they all?) and money. (See photograph 3.) After loading the safes with the goods they were closed and placed in position for the burn.





It was during this time we were able to peek in on the "the dark side" of a Fire Fighter. It became quite clear that Bolanoski and Dykstra are as adept at starting fires as they are at putting them out. In fact, after a little probing into their pyro-batic abilities, we came to realize that a fire fighter's definition of a "Good" fire is much different than what we are lead to believe. You guessed it. Barring any injuries, on a test fire, at least, the bigger the better.

Coming dressed for the fire, Bolanoski and Dykstra stacked the safes on a pallet in an enclosed area of the fire tower. Then, using scrap wood and other combustibles, they erected the makings of one nice bonfire. (See photograph 4.) Once the wood was sufficiently placed around the safes, Fire Fighter Dykstra used a road flare to get the fire started. (See photograph 5.)

The fire quickly engulfed the safes and licked the ceiling tiles, then filled the room, leaving the safes nothing more than blackened silhouettes in a ball of orange flame. (See photographs 6 and 7.) Outside, Lt. Bolanoski and the rest of our pyro-crew watched as the ceiling temperature quickly rose to 600°F. (Okay, so I lied about not using gauges and meters. But knowing the exact temp is sure a lot better than saying it was "really hot.")

4. (top)

Lt. Robert Bolanoski strategically places wood around the safes to give us the best burn.

5. (center)

With the safes ready for the burn, Fire Fighter Jim Dykstra uses a road flare to touch the blaze. Let the party begin!

6. (below-left)

The fire starts quickly. Ceiling temperature jumps to 600°F.

7. (below-right)

Soon the safes are engulfed and the tower is filled with flame and temperatures reaching 800°F to 900°F.





Continued from page 70

While watching the fire, we had opportunity to learn a little bit from Bolanoski and Dykstra about what it takes to be a fire fighter; the testing and requirements, the dangers, and some of the differences between fire fighting today and fire fighting in days gone by.

Some of the more interesting facts include the following:

- By requiring smoke detectors, major and life threatening fires have been drastically reduced over the past 10 years.
- "Emergency 51" is not a real life depiction of a fire fighter.
- And, in order to be a fire fighter in the past, you were required to sport a beard. How come?

(I'll tell you what - here's your challenge. The first locksmith to give me the correct answer by mail or by E-mail will receive a free Technitips Handbook. The winner and the answer will then appear in the June 1995 Bits & Pieces section of *The National Locksmith*.)

The temperature steadily rose and leveled off between 800° F and 900° F, where the safes stayed for the next hour. During this time the intense heat of the fire caused the outside of the safes to become red-hot and swell like balloons. Dials, escutcheons, handles and accessory locks all melted off the safe doors. (See photograph 8.) Water was sporadically showered on the fire to prevent too high temperatures from destroying the expensive tiling inside the tower.

Soon, the fire started fading and Bolanoski and Dykstra intermittently showered the fire with water, creating large white plumes of steam that escaped out the roof of the tower. The fire was out. (See photograph 9.)

Still hot to the touch, the fire fighters removed the safes from the tower. The wheels of the Meilink, still glowing red, sizzled and steamed as it was rolled out into the snow. (See photograph 10.)

The contents?

Read the following article by Dale, and he'll tell you how he opened the safes and the status of the contents.

We want to thank the Streamwood Fire Department for the use of the fire tower, and to Fire Fighters Lt. Bolanoski and Dykstra for their time and experience in making and controlling the fire.

Fire Fighter Lt. Robert Bolanoski is a 17 year veteran and Fire Fighter Jim Dykstra a 13 year veteran with the Streamwood Fire Department.



8. (top)
Our volunteers have lost their dials, escutcheons, handles and accessory locks, but do they lose face?

9. (right)
The pyro-crew wrapping up a fine burn.

10. (center)
Streamwood Fire Fighters Jim Dykstra (left) and Lt. Robert Bolanoski pose with our two singed volunteers.

The contents of the safes? See Dale's article on the openings!





FIRE SALE

**AFTER BURNING THEM, WE OPENED THEM.
FOLLOW AS DALE UNCOVERS
THE CONTENTS OF THE SAFES.**



by
Dale Libby

Last week I participated in the burning of two rated fire safes. This was accomplished at the Streamwood (Illinois) Fire Department "Fire Tower" and burning booth.

The safes tested were a Sentry Model 3140 2-hour rated unit and a Meilink Model 251 1-hour unit. On the day of the test, it was a chilly 22°F. Inside, the temperature of the safes was between 800°F to 900°F. The firemen cooled the room with water to keep the temperature from going too high.

In the background someone was chanting, "Weenies, Marshmallows,

and Smores." I was not surprised to find it was me that was doing the refrain. I had not had lunch yet. My job was to help set up the test, and afterwards to open the fired units. After the safes were thoroughly 'cooked', I took them to my work area to open.

While the fire safes were being burned, they both glowed cherry red and let off a lot of steam. The back of the sentry safe loading hole fell off and the steam came out here. With the Meilink, there were vent holes that let off steam, plus plenty of vapor was coming from around the door. Both safes were somewhat deformed from

the heating. Did they keep the money and contents safe from the fire? We shall soon see.

Of the two safes, the Meilink was easier and much faster to open. In fact, the Sentry safe had directions for opening a burned safe included inside of it. These directions would have made the Sentry safe much faster to open, but we will cover that shortly.

Meilink Opening

I was not permitted to take these new units apart before the burning to see if anything was new. The only thing I noticed was a cam type key lock to the left of the opening handle.



1. Outside view of melted handle and dial and dial ring on the Meilink safe.



2. The melted dial and handle were removed, notice that the key lock has also melted.



3. Interior configuration showing cam lock in the locked position.

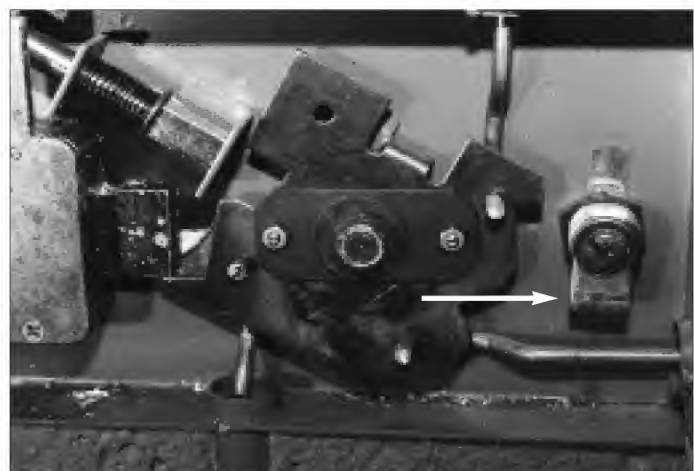

4. Cam lock in the open position. This will allow the locking plate to turn.

**Sentry 3140 Safe
In case of fire**

- * During the fire, tell the fire department where you keep your safe, so it can be cooled with a fine spray of water or CO₂ fire extinguisher.
- After the fire:
 1. Let the safe cool completely before opening it.
 2. Then, pry open the angled steel plate on the door front (Figure 1).

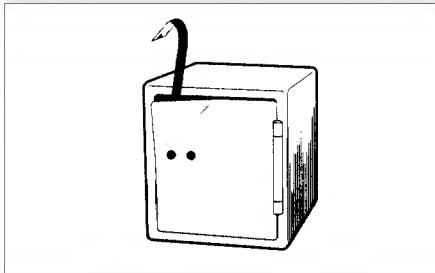

Figure 1.

3. Chip out the insulation until you see another metal plate below.
4. With tin snips or a metal saw, cut each side of this metal plate (Figure 2). Remove it.

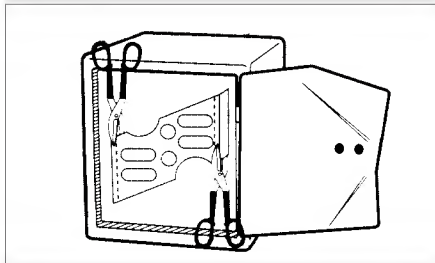

Figure 2.

5. Remove the rest of the insulation until the interior door panel shows.
6. With a sabre saw, cut out this molded panel (Figure 3) and remove the contents.

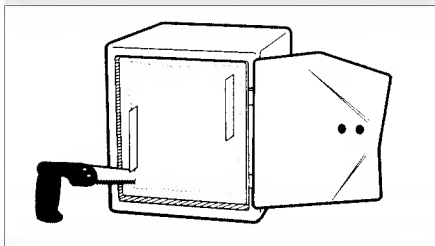

Figure 3.

- * To obtain a replacement product, please see your Owner Satisfaction leaflet.

We put some money into the safe along with the safe directions for operation and a copy of the directory issue of The National Locksmith.

The dial was turned and the key lock was locked. After the fire, the door looked as if everything had melted. The handle was gone, the cam lock had melted, and the dial and ring were a glob of molten metal. (See photograph 1.)

I cleaned the front off with a screwdriver and small hammer. What was left of the handle came off smoothly leaving a splined piece of

metal. The cam lock was melted, so I forced a large screwdriver into the hole and turned the lock till it was free spinning. (See photograph 2.)

Next, I grabbed the end of the combination lock spindle with a pair of needle nose pliers and tried to turn it. It rotated almost one full turn before binding up. Repeated oscillation of the dial spindle did not free up the wheel pack. It bound up when turning in either direction.

Before grabbing my drill, I played with the handle. If one pushed it in, it was free spinning. This was new.



**It's not safe
unless it's
Schwab Safe.**

[Click here for more information](#)

MINI SECTION

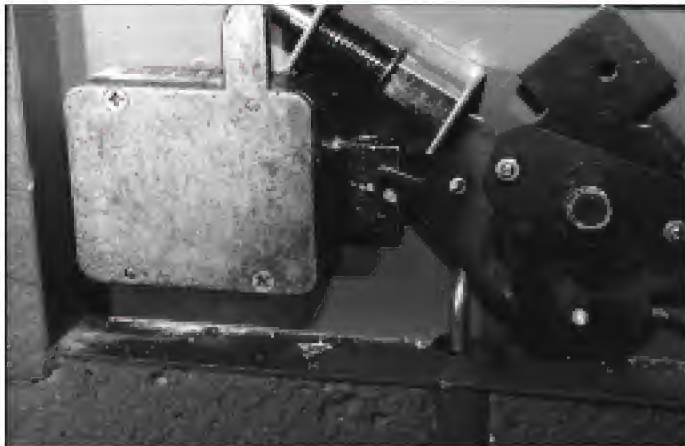

5. Locking plate bypassing the lock bolt opening safe door.

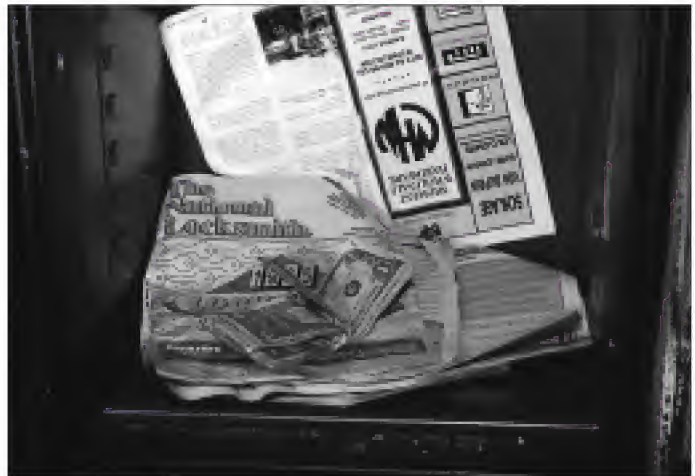

6. Aftermath, money and magazine safe, but wet.

Usually the handle was riveted or screwed on to the opening lock cam. I reasoned correctly that if the lock cam and the opening cam were not connected, playing and rattling this for about a minute while pushing and pulling out on the handle cam would reconnect it to the opening cam the door opened.

Photographs three and four show the inside configuration of the new Meilink Safe door. In photograph three, the cam lock is locked, and in photograph four it is in the open

position. This is a nice improvement. The lock used is still the Meilink small hand change S&G type lock, reminiscent of the 6709 series combination lock.

Also, the "T" handle of the opening handle can be seen to contain two brass screw studs at 3 and 9 o'clock. These are the shear screws that are now being used instead of the rivets or through screws as on the older units.

Photograph five shows the reenactment of the opening. With the outside opening handle pushed in and a little wiggling, you can get the opening cam to bypass the lock bolt. An alternative opening would be to drill for the edge of the opening cam, stick in a punch and bend it back far enough to bypass the lock bolt.

I am sure picking the cam lock will be very easy on this unit if that was also locked.

When the door, which was quite rusty at this time, was opened, the results were seen in photograph six. The money and paper were alright. The top bill and the top of the magazine were discolored and smelled like smoke. All the paper in the safe was somewhat wet and wrinkled, but the money spent just fine.

I then took apart the wheel pack on the combination lock to see why it would not turn. The wheel pack is plastic and it had not melted, however it seemed to be glued

together and warped. No amount of force would free up the wheels. I measured the post of the wheel pack and it seemed warped. Maybe this was why it would not turn.

A quick opening of this safe can be accomplished by using a Milwaukee Sawzall and a 8", 24 toothed Hackmaster saw blade. Time to open this safe by playing with the opening handle, 5 minutes. Time to cut top of safe off, 12 minutes.

Sentry Opening

The opening of the Sentry 3140 2-hour fire safe proved to be rather fun and enlightening, and perplexing and frustrating and diabolical. As I already stated, the correct procedures for opening a safe of this ilk that had been in a fire were outlined in the directions. Of course, I did not read these in advance, and the directions were locked up with the magazine and money in this safe.

This unit also sports a locking handle as well as the standard Sentry direct drive type lock. The fire insulation in this safe is called "PYRONOX" and gives a two hour UL



7. Melted front of Sentry 3140 Fire Safe.

Lockmasters has a 44 year history of training security professionals.

[Click here for more information](#)

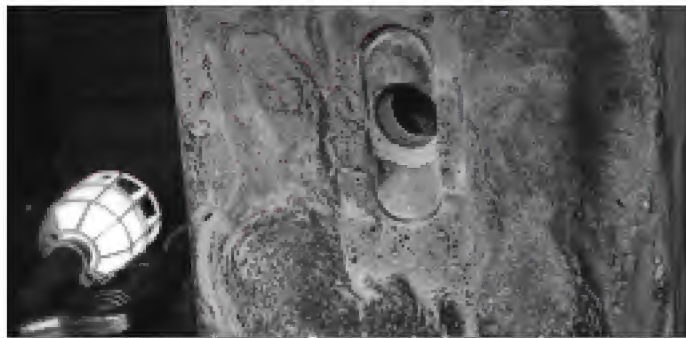

8. Rear "Deadbolt, 2-1/8" hole" entry of Sentry Safe.

endurance test as well as handling the UL Explosion Hazard Test. The neat thing about this fire safe is that the inside is all plastic with two adjustable and removable trays. There is no moisture in this safe, so not only would it be good for documents, but also hand guns. They would not rust in this plastic environment, not even in a fire.

I thought that this safe would be the easier top open, and if I had used my Sawzall Method, the safe would have opened in 8 minutes. I did saw the top off later to see how easy it would have been. The included directions use a similar method for opening. I will mention that at the end of this article.

Photograph seven shows the front of the fired Sentry safe. The handle has been totally melted off and the dial and ring are a shapeless mess of melted plastic. Other than the wheel pack and the six gear driven bolts and a metal laminate in the door and around the outside of the unit, this safe is totally plastic. A light bulb did not go off in my head at this time

The first attack consisted of a deadbolt opening. I drilled a 2-1/8" hole in the back of the safe where the fill plate was located. (See photograph 8.) This took about 2 minutes to get a hole through the back insulation and the plastic liner. I could see the money and magazines through this hole. I spent the next 45 minutes in a foolish pursuit to open the door of the safe from the back.

There is a back cover that can be removed to expose the back of the safe. The one screw securing this cover is located at the upper edge of the door toward the opening side. After removing this screw, I pried the cover back and down. I saw approximately what is seen in photograph nine.

There is a large plastic gear and the familiar Sentry two-wheel and driver wheel pack. Interesting to note, the drop-in point for the wheels is at about 4 o'clock as viewed from the front of the safe. If you had to drill this on a non-fired unit, then a good point would be at about 2 o'clock about 2" out from the spindle center. A borescope would

let you line up the wheels easily at this point.

I used the hole I drilled to force the wheels to line up with the fence. With a pliers on the front of the safe, I eventually managed to get the bolts to move to the unlocked position. It took about 35 minutes for this and it literally accomplished nothing! I tried to open the door from the back by pushing, but it would not budge. Photograph 10 shows a close up of the combination lock wheels and the six gear driven opening bolts.

MINI SECTION

HPC, Inc.
Designing Excellence and Manufacturing Quality since 1956

[Click here for more information](#)

MINI SECTION

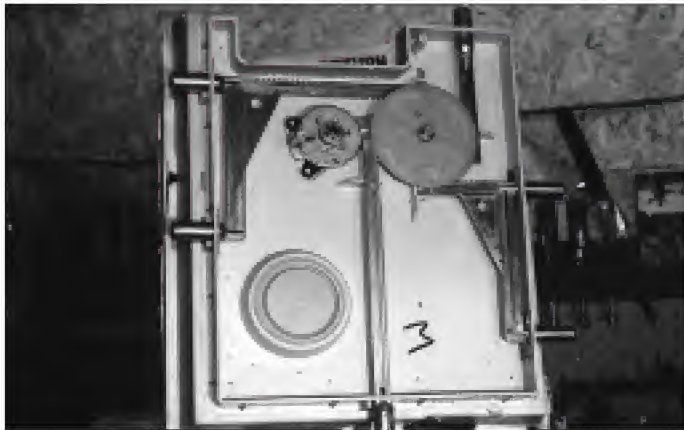

9. Inner bolt and wheel pack configuration of Sentry Door. Bolts are geared. Large plastic wheel has gears on back.

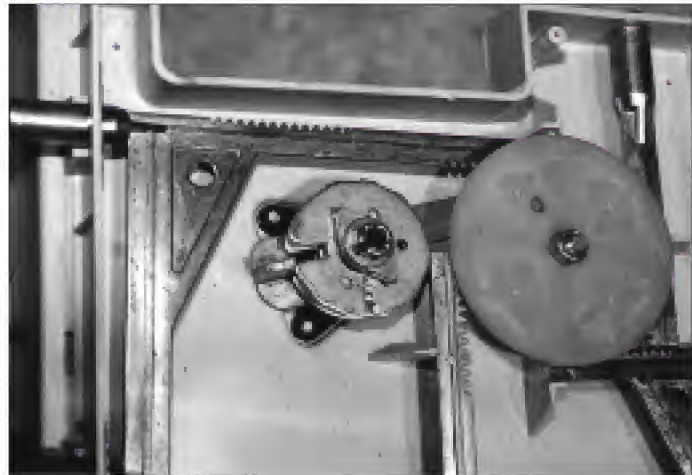

10. Close up of wheel pack and geared locking bolts.



11. Corner Pried off safe door to exposed melted plastic door edge.

I went to the front of the safe (what I should have done at the beginning), and pried back a corner of the door. The outer skin gave easily. The door



12. Opening side of safe door with insulation removed to show melted edge of door and the interior metal laminate.

remained tightly shut. I chiseled away some of the insulation and could see that the inner and outer edge of the door had melted together. Apparently, this Sentry safe has a coating that when heated by a fire, fills the gap between the door and the container, literally sealing the unit up. This can be seen if you look

closely at photograph 11.

I went around the door and chiseled out all the insulation and slowly broke open the edge of the door. Photograph 12 shows the edge of the door melted together along with the metal interior laminate. The correct way to open the door according to Sentry are summed up here in six steps: (See Sentry "In Case Of Fire" Sidebar, page 75.)

1. Let the safe cool before opening it. (I did!)
2. Pry open the angled steel plate on the door front at the upper left corner. (Again, I did this too!)
3. Chip out the insulation until you see a metal plate below. (See photograph 12.)
4. With tin snips or metal saw, cut each side of this

metal plate and remove it.

5. Remove the rest of the insulation until the interior metal panel shows.

6. With a saber saw, cut out this molded panel and remove the contents.

Photograph 13 shows the contents of the Sentry Safe after the fire. Again, the money was smoky and smelly, and it was completely dry. If you look at the top of the magazine, you can see the outline of the money as it was laying in the safe during the fire.

I was quite impressed with both safes in the test. They both worked and kept the contents from being destroyed. If I had to open a fire safe like this after the fire, I would probably opt for the reciprocating saw and long blade method of opening these units, depending on what exactly was inside. The cut open method is simple and fast, and with care the contents will not be destroyed by either the opening or the fire. Open And Prosper!!



13. Money and magazine in the Sentry Safe. Smoky and dry!!!!!!



MINI SECTION

Calling itself a fire/media safe doesn't guarantee that it is. Check to make sure that the safe or cabinet is rated and labeled, usually by UL, for the task. All Schwab fire/media safes and cabinets are UL rated.

BUYING FIRE SAFES: AVOID THE HEAT

Any safe may look tough on the outside. However, different safes offer different levels of fire protection.

Whether buying for resale or for end-use, understanding how, and how well, safes protect their contents from fire is extremely important. After all, the reason a consumer buys a safe is for security, right? Loss of vital business or personal records from fire can be as devastating as if they were misplaced or stolen. And don't be fooled. Any safe may look tough on the outside. However, like different locking mechanisms, different safes offer different levels of fire protection.

There are two main categories of fire-protective safes:

1. Those that are designed for the protection of paper records, and...

2. Those that are designed for the protection of film and computer media.

Paper will char and burn at temperatures of 420°F and above. A fire-protective safe designed for the protection of paper records will keep its internal temperature below 350°F.

On the other hand, film and computer media are much more sensitive than paper. They can be destroyed by temperatures above 125°F. In addition, computer media can also be rendered useless by moisture and humidity. A fire-protective safe designed for the protection of film and computer media will prevent this type of loss as well. It is important for the consumer to know which type of records they plan to store.

All fire-protective safes designed for the protection of paper records work basically the same way. A cement-like insulation is poured between the exterior surfaces of the safe and its inner walls. This insulation contains water. During a fire, the insulation becomes hot and converts this water to steam. The steam keeps the safe's contents moist and cool, and the internal temperature below 350°F. In production, the safes are baked to precise weights in order to dry the insulation and release a predetermined amount of the steam, thus controlling moisture.

Safes designed for the protection of film and computer media operate much like paper record protective safes, with one main addition — a second inner tank. The purpose of the second inner tank is twofold:

1. To add additional insulation to the safe and keep its internal temperature below 125°F.

2. To control humidity.

Remember, computer media can be damaged in an environment in excess of 80% humidity. The outer insulation of the safe still gives off steam, but instead of directly cooling the innermost contents of the safe it cools the inner tank. Materials stored in this chamber are kept cool and dry because the steam never reaches the media.

The inner tank of media safes is often surrounded by a wooden frame and wooden door that is filled with a foam core. Together, they form an airtight seal when the door is closed. As the heat of a fire causes steam to



MINI SECTION

be released from the outer layer of the safe's insulation, the wood absorbs the moisture from the steam and expands, thus creating an even tighter seal to the inner tank. Many new safes on the market utilize plastic and rubber seals on a single, outer door to create the same effect.

Quality safe manufacturers often elect to have their products tested by Underwriters Laboratories, one of the world's most trusted authorities on product quality. (See photograph on previous page) A quality fire protective paper record safe should bear some type of UL certification — usually UL Class 350 1-hour or UL Class 350 4-hour. UL performs three main tests:

1. (Required) Internal Temperature Test — UL places the safe into an oven and raises the temperature of the oven to 1700°F. A UL Class 350 1-hour certification means that the safe can withstand this extreme temperature for at least one hour while keeping its internal temperature below 350°F (a UL Class 350 4-hour safe will successfully keep its internal temperature below 350°F during a

four-hour exposure period to 2000°F, and so on).

2. (Required) Explosion Test — UL places the safe directly into a 2000°F oven for 30 minutes. This dramatic change in temperature simulates a heat blast which the safe might encounter in a fire. Dramatic changes in temperature could cause many materials, safes included, to explode. A quality engineered safe, as attested to by UL certification, will not explode during this test.

3. (Optional) Drop Test — Some manufacturers submit their products for a drop test. UL drops the safe, while hot, 30' into a pile of rubble. This test simulates a three-story fall through floors during a fire. A successful safe will not fracture nor have its interior protectiveness adversely affected by the drop.

Quality media safes should also bear a UL classification. Explosion tests and drop tests are conducted in the same manner as those done for paper record protective safes. However, as part of the internal temperature testing, media safes must undergo a critical cool down period following their exposure to the 1700°F oven. During this time, the safe must continue to keep its internal temperature below 125°F and its humidity below 80 percent until the exterior temperature of the unit drops to 120°F. This process can take as long as 68 hours. Safes that successfully keep their temperatures below the 125°F and 80 percent humidity marks for one hour plus the cool down period receive a UL Class 125 1-hour certification.

Don't overlook the importance of UL testing. In some cases, a manufacturer's certification that is not backed up by any kind of covered contents warranty may not meet UL standards. In addition, foreign labels are not, in most cases, equivalent to UL. Look for UL certification.

With a variety of different companies selling fire-protective safes, it's important for you to determine the cream of the crop. Here are several other factors you should consider when purchasing fire-protective safes for resale or end-use.

1. Sufficient Product Warranty — Each safe should have at least a one to two year from date of purchase warranty to cover defects in material or workmanship. The majority of defects will be found immediately. If you haven't had a problem with a unit within the first two years, you probably won't have one.

2. Covered Contents Guarantee — If a fire-protective safe fails, what happens? Manufacturers should back their product with a covered contents guarantee in the event of failure. One manufacturer guarantees contents up to \$100,000. That's known as standing behind your product.

3. Free After-Fire Replacement — If any time during the life of the product a fire should strike, the manufacturer will replace the safe at no cost. This makes a safe with this kind of guarantee a one time, lifetime purchase.

4. Reputable Manufacturer — After reviewing the guarantees and warranties on their products, look into the reputation of the manufacturer. You'll find certain companies are most always associated with quality and backing up their claims.

5. Flexible Interior Configuration — There are many different ways to configure the interior of fire-protective safes. As the consumer's storage needs change, often so must the interior of the safe. Look for a safe that is built to accept these changes as smoothly as possible in the field.

6. User-Friendly Appearance — Not all high quality safes have to look like a "safe." Manufacturers and professional safe resellers have recognized that data processing and record storage has moved from the back rooms and basements of businesses across the country into offices and other high traffic areas. Look for a manufacturer that may offer a more contemporary style in addition to their standard safe look.

Schwab Corp. is a manufacturer of fire and media safes and cabinets. For more information, contact Schwab at 317-447-8278.



Installation Tools

The Professionals Choice

[Click here for more information](#)

LIGHTER SIDE

What They Don't Know...

“You look like the cat who ate the canary,” I said to Don as he walked past my desk. “Everything went well on your service call, I trust?”



by
Sara Probasco

“Couldn’t have been better.” Don began to whistle a happy tune.

I couldn’t stand the suspense. Rising from my desk, I followed him into his office. “Well?”

“Well, what?” he asked.

“Tell me what happened.”

“Oh, nothing much. You’re just married to a genius, is all. At least that’s what Mr. Collins said I should tell you.” His smile widened.

Finally, I pulled it from him.

A customer by the name of Collins had called in, saying he had lost the keys to his vehicle. He gave Don the appropriate numbers, and Don cut a key by code before leaving the shop – a fact he did not mention to the customer. Arriving at the scene, Don walked directly to the vehicle, inserted the key, and opened the door.

“Wait a minute!” said Mr. Collins. “How’d you do that?”

“Nothing to it,” Don replied, “if you know how to hold your mouth.”

“Now, listen. I’ve lost keys before, when I was in the city, and I had to call a locksmith. They fiddled around, filing on the key blank and jiggling it around in the lock, or running any number of opening tools down inside the door, or whatever. It took them a half-hour or so to get it open. You didn’t do any of those things, and you got right in. I was watching you. You just walked up to the door and opened it with that key. How did you do it?”

Smiling, Don used his old stand-by phrase: “It’s magic!” Then he confessed: “Actually, I cut you a key from the code numbers you gave me, before I left the shop. When you know what you’re doing, there’s nothing to it.”

“Well, I’ll be. I had no idea you could do that. I guess that’s why I’m a rancher, and you’re a locksmith.”

“Could be.”

Fortunately for Don’s image, the code was a valid one. There have been times the numbers weren’t right, and such a key wouldn’t work the lock at all. This time, Pontiac Roadside Service had come to his rescue, adding a little shine to his “halo,” where this particular customer was concerned.

We’re always a bit surprised at how little some customers seem to know about the capabilities of a good locksmith. Maybe their concept of what we do is more distorted by erroneous TV information than we realize. Magnum P.I. gave us fits, for years. Repeatedly, we heard, “well, it doesn’t take Magnum that long to open a door,” or “Magnum just uses a skinny, little wire to get in.” Our usual reply was, “Yes, and we don’t charge you what Magnum would, either!”

Last night, I watched an episode of “Murder, She Wrote” in which Jessica was trying to gain access to a locker-room locker in a community center. She had called the owner of a local hardware store, trying to get a key to the locker.

“I understand you often made keys (duplicates) for people at the city offices, and I suppose you make them for the lockers at the community center, as well,” Jessica said.

He admitted that people sometimes brought in such keys for duplication.

“If you can do that, then you must

have the master of the locker key I’m looking for,” she responded.

Do people really think we keep copies, or “masters,” of all the keys we duplicate? Apparently some people do. Every now and then, we get a call from a customer who has lost a key, wanting to know if we still have a copy of their key from when we duplicated it months – even years – ago!

A call came in the other night from a customer who comes into the store occasionally for locks and key duplication. This was the first time he had called us to retrieve keys from inside a locked vehicle. Over the telephone, he kept trying to find a complicated way to solve his problem.

“No problem, John,” Don assured him. “I can come right now and get it open for you.”

“You mean you can get it open without a key, or key number, or anything?”

“Sure. No problem. I’ll be right out.”

That didn’t end the conversation, however. John found the concept inconceivable and pressed for more information, while Don tried to get off the phone and out there to do the work.

By the time Don arrived at John’s location, John’s daughter had arrived with a spare key.

“I’m sorry we called you out, this way, on a weekend,” John apologized, reaching for his wallet. “What do I owe you?”

“No charge,” Don replied. He was in a benevolent mood.

“No, no. That’s not fair. You came all the way out here. I want to pay you for your time.”

Continued on page 114

THRU THE KEYHOLE

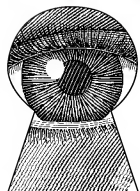

**A Peek at
Movers & Shakers
in the Industry**

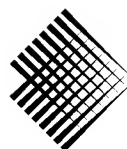

STRATTEC™

ATTENTION MANUFACTURERS AND DISTRIBUTORS: Would you like your company and products to be profiled in Thru The Keyhole? Please call Managing Editor, Tom Seroogy at (708) 837-2044.

So, What's In A Name - STRATTEC?

When one of the world's leading manufacturers of automotive locks decides to change names, what's in store for the locksmith?

Briggs & Stratton Technologies is no longer a world leader in supplying locksmiths with quality locks and keys for cars, trucks, boats and recreation vehicles. The new STRATTEC SECURITY CORP. now commands that spot.

No, Briggs & Stratton Technologies did not slip and fall behind a newcomer named STRATTEC. On the contrary, Briggs is STRATTEC SECURITY CORP. In the past, Briggs & Stratton Technologies operated as a

division of Briggs & Stratton Corp., known internationally as a maker of high-quality small engines. However, in January the lock division became a separate company and changed its name to better reflect its position as an industry leader in providing locks and keys, service packages and technical support services.

The biggest change for locksmiths is that they will no longer see the familiar red and black box containing Briggs & Stratton locks and parts. In its place is the red and white box of STRATTEC. (See photograph 1.) However, the products inside the boxes will not change.

The company's engineering, production and management teams remain the same. STRATTEC will continue to manufacture and assemble locks at its facilities in Milwaukee, Wisconsin, and Juarez, Mexico. The company is headed by Harry Stratton, formerly vice president and general manager of Briggs & Stratton Technologies, now president and CEO of STRATTEC. The distribution network and field representatives



2. STRATTEC will continue to produce a full line of lock products for the automotive, marine and recreation vehicle markets.

haven't changed, meaning locksmiths can find STRATTEC products and technical information from existing sources.

The name change, however, gives STRATTEC its own identity and draws attention to the company's locks, keys and technical support services. Despite the change in name, locksmiths will continue to get the highest quality hardware and information needed to do the best job possible.

Tradition Carries On

STRATTEC will continue to supply factory original replacement parts for Chrysler, General Motors, many Ford locks and other manufacturers. (See photograph 2.)

The company also will continue to provide up-to-date literature identifying locks, keys and other parts, as well as their proper applications. Look for an update to the AS-1975 Manual and its components, including technical service bulletins, the Professional's Choice service catalog and Lock and Key catalogs.

Continued on page 114



**ASP - Your Auto
Service Center
for the World**

[Click here for more information](#)



1. The once familiar red and black box of Briggs & Stratton will now be replaced by the red and white box of STRATTEC.

TECHNITIPS

Helpful hints from fellow locksmiths

Send in your
tips and win.



by
Jake Jakubowski

HOW TO ENTER

Simply send in your tip about how to do any aspect of locksmithing. Certainly, you have a favorite way of doing things that you'd like to share with other locksmiths. Write your tip down and send it to: Jake Jakubowski, Technitips Editor, **The National Locksmith**, 1533 Burgundy Parkway, Streamwood, IL 60107 or send your tips via E-mail to the E-mail address posted in the upper right hand corner of this page. Remember, tips submitted to other industry publications will not be eligible. So get busy and send in your tips today. You may win cash or merchandise. At the end of the year, we choose winners for many major prizes. Wouldn't you like to be a prizewinner in 1995? Enter today! It's easier than you think.

BEST TIP OF THE MONTH

If your tip is chosen as the best tip of the month, you'll win \$50 in cash! Plus, you may win one of the large year end prizes!

EVERY TIP PUBLISHED WINS

Yes, every tip published wins a prize. If your tip is printed, you'll win \$25 in Locksmith Bucks. You can use these bucks to purchase any books or merchandise from The National Locksmith. Plus, every tip published will win a copy of the Technitip Handbook. (Please remember to include your complete mailing address - we cannot mail prizes to P.O. Boxes.)

America Online: NATL LOCK

Use the above address if you are on AOL.

Internet: natllock@aol.com

Use the Internet address if you are not on AOL.

✉ - letter ✉ - E-mail

These Prizes Awarded Each Month!

- All-Lock Foreign Auto Service Lists - Worth Over \$225.00!
- American Lock & Supply - \$50 Merchandise Certificate
- HPC Pistolpick
- Silca Rubberhead Keyblanks (100 Blanks)
- Pro-Lok PK15 Professional Lock Pick Set
- Sieveking Products EZ-Pull GM Wheel Puller
- A-1 Security Mfg. Quickpull
- Major Mfg. HSK Safe Hinge Shim Kit

Submit your tip and win!

As Jerry Clower allus said:
"Whooooeeeee!"

I'm as excited as a kid in a candy store. If you haven't noticed, the monthly and yearly prize structure for the Technitip winners has changed.

In addition to our old friends like All Lock, Silca, Sieveking Products, Foley Belsaw and HPC, we've added a whole bunch of new sponsors!

For our monthly winners we've added Pro-Lock (A Prolock pick set), A-1 Security Products (The A-1 Quickpull), American Lock & Supply (A \$50 merchandise certificate), and Major Manufacturing (A different Major product every three months)

For our year-end winners we've added Auto Security Products (\$500 worth of merchandise), Curtis (A Curtis 1000 duplicators to two winners), DeWalt (A DW991K 14.4 volt cordless drill), Framon (Impressioning Handle), and Hayman Safe Company (A Hayman FS4000 in-floor safe).

And ... there's more to come
Whooooeeeee!

Starting this month, I'm going to award grab-bag prizes on a random basis (subject to availability) to those tipsters that have their tip printed! These special grab-bag prizes will be in addition to anything else we give

away that month!

You see, folks like MAG Engineering, Abus, Emtek, Pado and other manufacturers and distributors send me samples from time-to-time for promotional reasons. As I accumulate this merchandise, I'll start giving it away. If I can do it monthly, I will. But, these samples will be given strictly on a random basis. O.K.?

I want to thank all of our old and new sponsors for helping to make The National Locksmith's Technitip Column worthwhile and exciting. Each of those sponsors is dedicated to seeing this industry grow and succeed. That includes those companies that send in samples of their products for us to evaluate and inform you about (Which will become the grab-bag prizes).

Hey, y'all! My thanks to you too! If y'all weren't sendin' me them tips, I'd have to keep all the good stuff the sponsors are sendin' and don't want back! And remember this, there's beaucoupe THOUSANDS of dollahs worth a' Locksmiths Bucks, Machines, Equipment, Merchandise and Surprises being given away this year. Ya'll can't pass that up now, can ya'? So, gitch' y'all's pencils out an' start 'riting'. Y'all heah? Whooooeeeee! Whooooeeeee! Whooooeeeee!

All Lock Pinning Kits Winner
Tip Stop and Shim

Like many of my fellow locksmiths, I cringe when a customer comes into the shop and wants me to duplicate a removable core key. Those keys seem to be the most difficult to get set right in the key vices of the machine, since the keys have no shoulder stop. Usually, I gauge them from the bottom with a screwdriver blade ... and pray!



1. Plates added to the top of the jaws.

Well, I think I just might have found the best alternative.

I took the top jaws off of my Ilco 017 duplicator and then drilled and tapped them for a 6x32 machine screw. I made two flat steel plates and drilled a corresponding hole for the screw and remounted the jaws on the machine. (See photograph 1.)



Photograph 2.

Now, when I have a run of IC core duplicates to make, I just loosen the screw, slide the plates into position and gauge the blanks with the underside notch on the blank against my new stop. It works like a charm every time. I have cut both control and operating keys with no problems.

When the need arises to make double sided duplicates, the adapter plates are simply swung up, out of the way, and locked in place. We've found that these stop plates also work well as a tip stop gauge for both regular and 10-Cut Ford keys!

Also, when cutting IC core keys, I've found a solution to keep certain

keys from rolling in the key vise. I just take a piece of solder, lay it on a good flat surface and lay a flat piece of metal (a name or number stamp works well) strike the metal with a hammer and flatten the piece of solder. (See photograph 2.)

When you lay the flattened solder along side the blank, and tighten the jaws, the solder will conform to the shape of the grooves in the blank and make a perfect shim. I know it sounds too simple but, try it on a few of those blanks that roll and see for yourself.

William B. Newns, Sr.
Pennsylvania

American Lock & Supply Merchandise Certificate Winner
Master Pick

Here's an easy way I have found to pick open a Master #175 resettable combination padlock.

I made a pick from a piece of a 1/2" wide tape measure and ground it as shown in illustration three.

Holding the lock with the wheels facing you and the "175" to your right, set the first wheel between numbers and insert the tip of the pick in the lower right hand corner of the wheel opening.

Push in on the pick and you feel it hit the small wheel inside the lock, turn the wheel to the next position and push the pick again.

When you feel the pick go past the small inner wheel, you have either hit the notch (which is what you want to find) or the flat area on the inner wheel. To find out which, rotate the number wheel to the next position. If

you hit the inner wheel, it's the notch that you felt. If you don't hit the inner wheel, it's the flat spot.

When you find the notch, let the number wheel fall to the next number and add three to that number. The total will be the correct number of that wheels combination. Do this to the other three wheels and the lock will open.

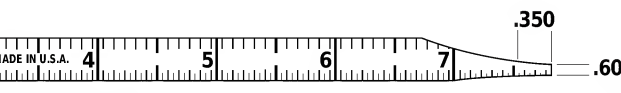

Illustration 3.

Al Bowman,
Missouri

HPC Pistol Pick Winner
Picking the Tibbe Lock

A recent newcomer on the automobile scene in Europe and other countries is the new Ford Mondeo. Because of a locking system that locks everything (doors, inside lock handles, boot, etc.), and since these newer car doors are heavily shielded and all rods have been replaced by cables, the car seems almost impenetrable in the event of a lock out.

However, the locks on these cars are made by Tibbe and by using the Tibbe lock pick set made by Souber Tools, you can gain entry to the car.

To successfully pick this lock, you have to gain tension on the number 4 disc (The lock is similar to the Abloy). There should be at least one #4 disc. Use the pick to move up and down the pack of six tumblers gently nudging the other discs into position After each time, go back to the #4 disc nudge it and see if the barrel is going to turn. If there is more than one #4 disc, nudge each in order.

As the other discs come closer to their position nudging the #4 discs in the lock with often cause the barrel to turn or cause the other discs to turn slightly until they fall into position

Continued from page 102

By using this method, we have, in actual fact, decreased the time involved to pick this lock. Seldom does it take more than ten minutes to do the job.

G. Watts
London

Editor's Note: Although the Tibbe Lock is found mostly in Europe and other parts of the world, it was used in the U.S. on the Ford Scorpio and I believe on some Jaguar models. Since The National Locksmith does have readers worldwide, I thought we'd pass this on to them. For U.S. locksmiths who want this pick, contact Mark Bates Associates at 606-858-0811.

Silca Rubber Headed Keyblanks
Winner

Schlage Cylinder Spacer

Every now and again, I find it necessary to use a 5-pin Schlage cylinder to replace 6-pin cylinders in Schlage locksets. Frequently, I do not have the clip or spacer that Schlage makes for this conversion.

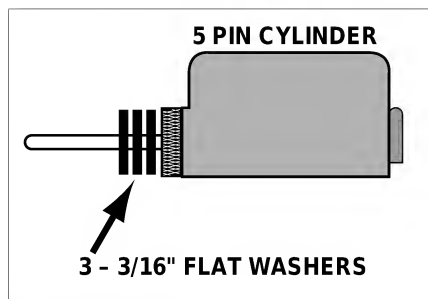

Illustration 4.

Recently, I found a quick, simple solution to the problem. Place three 3/16" washers over the tailpiece and against the plug retainer. Just make sure that the cylinder has the long tailpiece (they usually do) on it. (See illustration 4.)

George Lazich
Wisconsin

Pro-Lok Pick Set Winner
Best Lock Pick

Picking Best 6-pin and 7-pin cylinders and Arrow 6-pin cylinders can be difficult. I have found what I believe to be the best pick to use for opening these locks. It is pick #6 from Lock Technology, Inc. Auto Pick Set #340.

I begin by placing a thin tension wrench at the bottom of the keyway and apply turning tension to the right (clockwise).

Insert the serpentine end of the pick all the way to the back of the

cylinder, making sure that you have cleared the last pin. Hold the pick at an angle to match the keyway - not perpendicular to it. Now, rake the pins as usual.

If the cylinder does not yield, continue applying tension and turn the pick around to the diamond end. It may be necessary to reverse the pick more than once, but it works surprisingly well on these locks.

Always pick to the right. If the plug turns and it does not turn to the opening direction that will retract the latch or bolt, use your plug spinner to reverse direction.

Be sure to keep the pick at the proper angle, or it can become trapped when the plug turns.

James R. Ashcraft
Michigan

Sievekig Products E-Z Pull Gm
Wheel Puller Winner

GM Pick Up Door Lock Removal

I've been reading Technitips for some time now and I have read several tips on the removal of the late model GM C, full-sized pick-up truck door locks for the purpose of rekeying or producing a lost key. I have tried all methods successfully, but all were time consuming and extremely difficult. I have recently discovered a method that is so simple and fast, it's almost ridiculous.

First remove the inside door panel, (not the second inside metal door panel). Next use a 10mm socket and remove the two screws that secure the handle in place. As you know, removing the handle now is difficult because of the position of the linkage connected to the door handle.

Here's the trick. remove the three Torx head screws from the latch in the side of the door and this will relieve the pressure of the linkage on the door handle, and allow ample room to work. Now the handle can be easily pulled from the door to allow access to the cylinder. Do not remove any linkage, just allow the handle to hang outside of the door.

Next, remove the clip from the tailpiece. Be careful not to drop it, as retrieving it will not be fun. Let the tailpiece just hang on the linkage. Depress the retainer under the cylinder and push the plug out of the back of the handle.

To re-install the lock, first connect the cylinder to the tailpiece that's on the linkage. Then, push the cylinder through the back of the handle until the retainer is engaged securely. Put the handle back in position and replace the three Torx head screws in the latch assembly. Replace the two 10mm screws that hold the handle in place, replace the door panel, and you're done!

Brian Goodson,
Texas

Editor's Note: Brian's tip was the first of three that I received regarding these GMC locks. So, his got printed. However, I want to thank Dean Huff in Lake Wales, FL. and Ross Henderson from South Carolina for sending in theirs.

Recently I was in a hardware store and on the counter there was a display of a new type of battery operated scissors. They were very small and used two AA batteries to make them work.

A-1 Security Products Quickpull
Winner

Pick Gun Conversion

I always thought that it would be nice if I could make a pick gun that would move faster than a regular pick gun. I thought that these small battery operated scissors might do the trick.

With a little modifying to the blades of these scissors I made an economical, cordless, battery operated pick gun. (See illustration 5.)

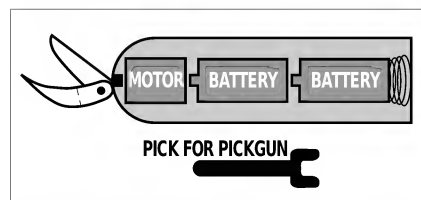

5. After removing the non moving blade, prepare the other blade for mounting the pick.

First, I cut off the top blade (the one that doesn't move) as close to the body of the scissors as possible. The blade that does move I cut to a shorted length (about half its length) and drilled a 1/8" hole. Then, I put a screw with a washer on both sides and a nut on the back side. I took a pick from my mechanical pick gun and attached it to the blade of the scissors.

Just flip the switch, and you're into Power Picking!

Jessie Cobb
Oklahoma

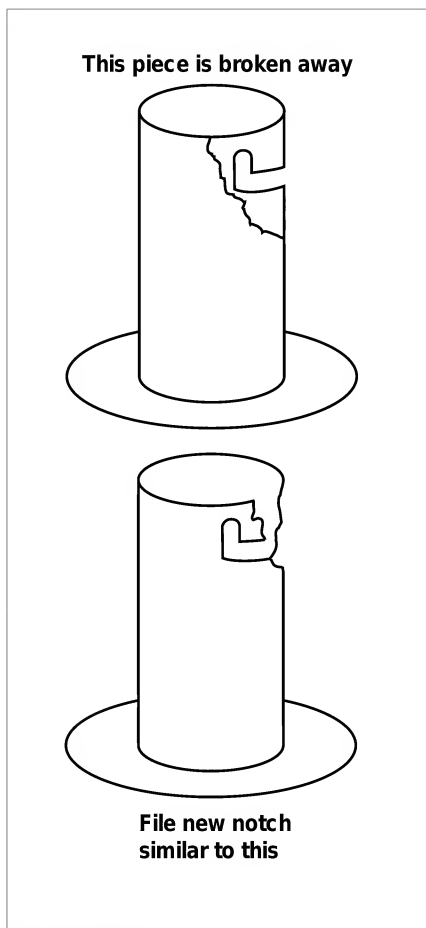

Illustration 6.

Major Mfg. HSK Safe Hinge Shim Kit
Horn Tower Repair

While recently disassembling a G.M. steering column, I noticed that the plastic tower on the horn ring had been broken and the spring loaded connector would not stay in place.

Not having a replacement ring, I used a warding file to carefully notch the tower as shown in illustration six to accept the spring loaded plastic connector. I just had to be careful to file the new notch at the same level as the original notch.

I reassembled the column, and everything - the horn included worked!
J. W. Stokes,
California

Grab Bag Prize Winners
Self Stick Labels

Today, its hard for a locksmith to try to compete with discount hardware stores and places like Wal-M art who can sell padlocks for the same of a lower price then we can buy them for. I found a way to increase my padlock sales and at the same time instill more confidence in my customers, with out a great deal of expense.

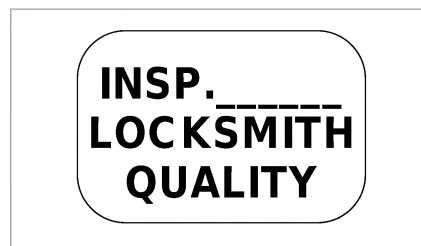

Illustration 7.

For the cost of a small rubber stamp and a box of 1/2" x 3/4", self-stick labels. I place this label on every packaged padlock that I have in stock. (See Illustration 7.)

When the customer tells me they can get that lock for half price somewhere else, I tell them that might be true and pointing to my label "of quality assurance", I tell them that they're buying this lock from an accredited locksmith that can rekey all of their padlocks alike and replace or service the lock if it fails. I also let them know that the discount retailers won't do this.

This little label has helped me sell more customers because it gives them piece of mind.
Lee Whiteford,
California

Continued on page 115



STRATTEC™

It's your reputation.

Trust the original.

[Click here for more information](#)

Making The Cut In Aluminum Door Service.

FOR THE MOST PART, ALUMINUM DOOR SERVICE WILL BE CONFINED TO REKEYING AND REPAIRING THE LOCK. THEN, AGAIN, BE PREPARED FOR THE EXCEPTION.

by Tom Seroogy

Not a week goes by when most every locksmith has to work on or service an aluminum door and frame. Since the strip mall boom began roughly 15 years ago, aluminum doors and frames have become a standard for most all new store and office center construction.

Of all the hardware available for these doors today, none has had the popularity and longevity of the swing bolt and deadlatch. While Adams Rite has had the lion's share of this market with their MS Bolt line and Dead Latch, other smaller manufacturers have been filtering in and introducing their own versions of this style lock. Today we'll take a short look at what is necessary for choosing and installing one of these units.

For the most part, the installation and service of these locks will be on a replacement basis only. The initial cutting of the door and frame is typically done by the manufacturer, and the lock installation is usually completed by a glazier or glass company.

The locksmith's involvement results when a rekey is needed, the tenant wants to change the lock function (latch to bolt, or vice versa), or the lock has become damaged. On rarer instances the locksmith may be asked to install a second lock/latch and/or an electric strike.

Whether servicing or making a fresh installation, the first two items of concern will be the backset and the door edge direction. Backsets will include 7/8", 31/32", 1-1/8" and 1-1/2". The most common of these backsets is the 1-1/8" with the 1-1/2" and 31/32" following close behind. Least common is the 7/8" backset. (See illustration 1.)

The door edge determines the shape or contour of the faceplate. The prevalence of any one style will depend greatly on what part of the

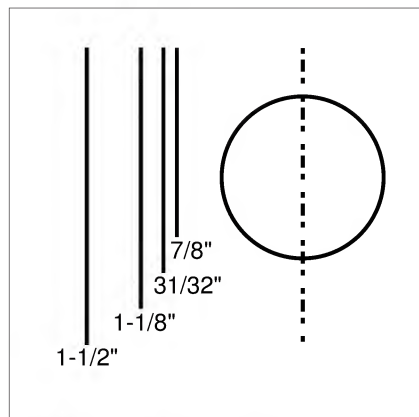

1. While some are more common than others, these backsets represent what may be found on the typical aluminum door that uses a swing bolt type lock.

country you are in and the age of the construction.

In the midwest, for example, common on double doors is the round or radiused faceplate. On most single doors a handed beveled faceplate is used. Used less frequently is the standard flat plate.

Because the faceplate for beveled doors are handed, it is necessary to first determine the doors handing. Fortunately, this is quite simple and is determined by the hinge side of the

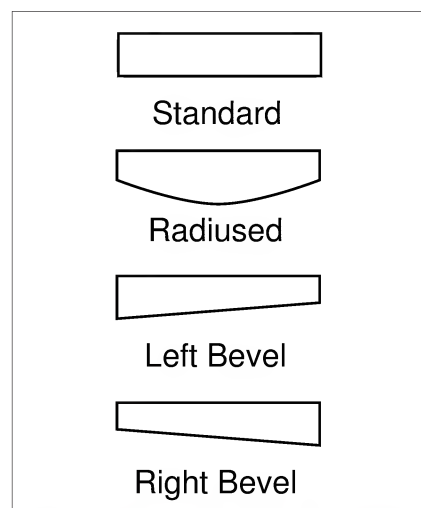

2. Representation of the possible faceplate contours.

door. Standing on the PULL side of the door, if the hinges are on the right, the door has a right hand bevel. If the hinges are on the left, the door has a left hand bevel. (See illustration 2.)

With backset and faceplate determined an installation is as follows:

For replacement, remove the faceplate screws and faceplate. Next, loosen the lock mounting screws; one will found at the top and one at the bottom. By loosening these screws, any pressure applied to the lock cylinder(s) and/or thumb turn has now been released, allowing them to be removed easier once the next step has been completed.

Loosen the lock cylinder/thumb turn set screws and remove the cylinder(s) and/or thumb turn. For Adams Rite units, these screws can be loosened using a small flat blade screw driver. For some of the manufacturers selling East Asian imports, it is sometimes necessary to use a metric Allen wrench to loosen the screws. If a lever handle or paddle are used (on the Latch unit), the lever



3. A fresh door ready to be cut.

or paddle and its drive cam must be removed.

Now remove the lock mounting screws. In some instances, springs will be attached to these screws. Make sure they do not drop into the door. Also, be careful that the whole unit does not fall down into the door stile. Placing a screw driver through the cylinder holes and lock is a good precaution to prevent this.

Reinstallation is the reverse of the above procedure. When doing so, make sure that the lock cylinder(s) and/or thumb turn are tightened evenly, centering the lock as much as possible in the door. Also, do not tighten the lock mounting screws until the lock is completely installed and it's time to put the faceplate on.

While for most locksmiths, fresh installations are much less common, they are profit makers. Locksmiths installing access control systems and electric strikes will find fresh installations more often and more profitable. (See photograph 3.)

Now, before doing a fresh installation, for the sake of making the

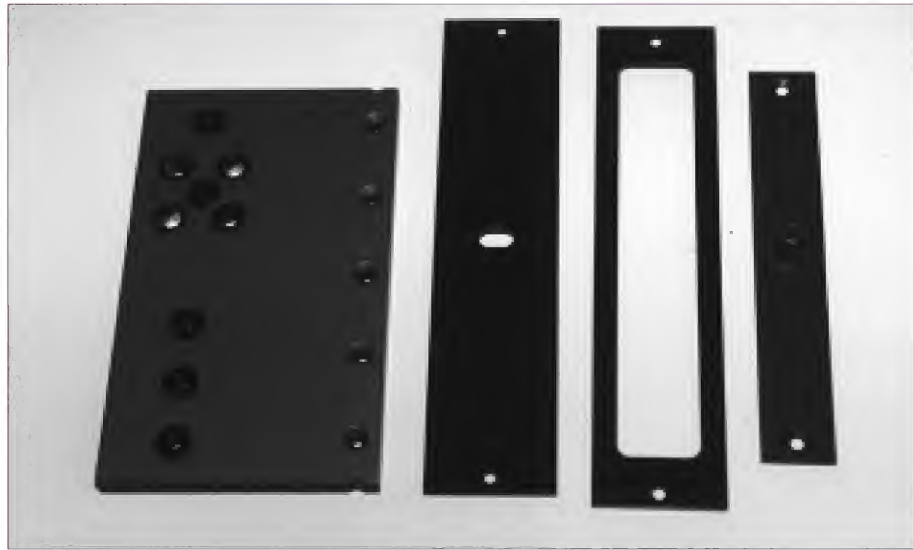

4. These HIT-45 Template accessories allow the locksmith fast and easy installation of some of the more common mortise locks.

job as easy and professional looking as possible, let's avoid using those methods and techniques from "Days Of Old." With the increasing number of companies that make guide tools and templates, there is no need to revert to drilling, sawing and filing to make these locks fit, except when absolutely necessary.

For this fresh install we used Major Manufacturing's HIT-45. Basically, the unit is simply a clamp. Available with this unit are template guides for installing Schlage L series mortise locks and Adams Rite style swing bolts and deadlatches. (See photograph 4.) Also available from Major is the template for installing the Adams Rite 7000 series (and comparable) electric strike.

medeco[®]
HIGH SECURITY LOCKS

**The market leader
in locking systems for security,
safety, and control.**

[Click here for more information](#)



5. After removing the existing push bar and pull handle, the HIT-45 is clamped to the door and ready for cutting.

To use the HIT-45, attach the correct faceplate and cylinder hole templates. Typical aluminum door locks have a 1"x6-7/8" faceplate. Three cylinder hole templates are available with the HIT-45; 1-1/8", 1-



6. Using a router, follow the HIT-45 template to make factory looking cuts.

1/2"- 31/32" composite, and 1-1/8"- 31/32" composite.

The 1-1/8" and 1-1/2"-31/32" composite templates include a guide for the Adams Rite position indicator. The 1-1/8"-31/32" composite template includes drill guides for the paddle handle. We used the 1-1/8" attachment.

Now, remove any hardware that may be in the way. If you are installing a secondary lock, make sure and remove the first lock before you start the routing. The aluminum chips caused by the routing will fall into the existing lock and cause it to malfunction.

Next, place the HIT-45 on the door and tighten the clamps. The unit will automatically center itself on the door. (See photograph 5.)

Drill a 5/16" diameter or greater hole for the faceplate and the cylinder hole. Then, using a router with a 1/4" down shear bit (also available from Major) and a 3/8" guide, slowly and carefully follow the template, in a clockwise direction. Going in the opposite direction will cause the router to walk and climb, causing the operator to lose control, thus yielding a bad cut. (Note: Remember to use both eye and ear protection during routing or when using any power tools!) (See photograph 6.)

Remove the HIT-45 and clean up any rough edges. (See photograph 7.)

To mount the lock it will be necessary to install U-Tabs or use Adams Rite mounting bridges. Properly installed, either style mounting fixture will provide an excellent and secure mounting base for the lock.

Install the lock as described above. (See photograph 8.)

Go to the frame, align and cut out the strike.

For electric strike installation, the Major electric strike template creates a clean, factory appearance cut allowing installation of ANSI (1-1/4"x4-7/8") sized electric strikes such as the Adams Rite 7000. (See photograph 9.)

DCI

**We have it all.
Quality,
Value,
& Service.**

[Click here for more information](#)



7. Remove the HIT-45 and clean up the door.



8. The lock installed.



9. This template by Major Manufacturing allows you to cleanly cut frames for electric strike installation.

To use, anchor the template on the frame making sure it aligns correctly with the mounting position of the strike. Remember, installed correctly, the deadlatch of the latch unit will ramp up onto the lock while the latch falls easily behind the latch lip.

Once positioned, attach the fixture to the frame using two self-drilling drywall screws, provided by Major. (See photograph 10.) The design of the template holds the mounting screws straight and centered, making sure the template doesn't walk during the mounting process. Also, holes



10. Use the self drilling drywall screws to attach the template to the frame.

produced by the fasteners are later used for the U-Tab mounting tabs. (See photograph 11.)

Drill a 5/16" or larger diameter hole. Then use the router to complete the cut.

Install the U-Tabs, terminate the strike, and finish the installation. (See photograph 12.)

For more information on the HIT-45 contact Major Manufacturing, Inc. at 714-772-5202.



11. The finished cut includes holes for attaching the U-Tabs needed for mounting the electric strike.



12. After checking for the initial fit, the U-Tabs were installed and the strike mounted to the frame.

SRI
SECURITY
RESOURCES INC.

SRI and Steve Young are working together to bring you the best in locksmith tools and supplies.

[Click here for more information](#)

BITS & PIECES

Informative Tidbits for the Security Industry

I have been receiving a lot of calls on opening the new Ford Contour and Mercury Mystique.



by
Tom Seroogy

According to Michael Hyde, technical writer, be careful as the door is filled with electrical looms that can be damaged.

Michael suggests using an Under-The-Window tool to pull back on the inside latch release handle. This is an active handle and will unlock and open the door when it is pulled on.

According to a recent issue of the American Business List, locksmiths shouldn't be starving for auto work. According to the report there are 24,943 New Car Dealers, 73170 Used Car Dealers, 64618 Body Shop & Repair Stores, 22,666 Auto Rental/Leasing Stores, 182,292 Repair/Service Stations, 83,406 Service Stations, 558 Auto Auctions and 1275 Repossessors throughout the country.

When you add that up, there's almost one-half million opportunities for locksmiths to make money doing auto work. And considering that there are only 14,141 locksmiths in the country, there's plenty to share! (These are probably listed locksmith companies and not individuals.)

Granted, auto work is not for every locksmith and different areas of the country may not have all that many dealers and shops. But for most of us, there seems to be plenty.

Auto-Security Products has some new products to make our job easier. The C-30-129 Toyota ignition used for the 1992 and up Camry using the split wafer system. Dealer cost on this lock is \$54. ASP price is \$39.

Also new are the ignitions for the 95 Hyundai Sonata. Use C-36-109 for

manual transmission and C-36-110 for automatic. Use pinning kit A-30-106 for keying. Dealer cost is \$60.88. ASP cost is \$20.50.

The 95 Kia Sportage uses the same ignition as its predecessor, the Sophia, C-40-101 (manual trans.) and C-40-102 (auto trans.). Cost for lock components from ASP is \$18.75. Dealer cost is \$136.80 (manual) and \$123.20 (auto). Use Hyundai pinning kit A-36-101 for keying.

The door locks on the Sportage are different than the Sophia and are handed. Use D-40-103 (passenger) and D-40-104 (driver). Use Toyota kit A-30-104 for keying. Cost on the door locks are \$14.40 from ASP and \$26 to \$30 from a dealer.

Pro-Lok has just released their new 1995 Car Opening Update. The update includes 150 new vehicle openings and costs \$18.50. Also, available are the Honda, Toyota and Nissan service manuals. These manuals include service procedures for cars from the early 1970's through 1992 and 1993. The updates and the manuals are available from Pro-Lok distributors.

1995 Chrysler update. Changes to the 1995 Chrysler/Jeep products were to include tumblers in all seven spaces of the door lock and a fixed pawl on the door lock. There have been reports from the field, however, that many of the '95 Chrysler cars are still equipped with the older keying system. Also, to date, a fixed pawl has not been found on any new American made Chrysler product. Even a recently ordered 1995 Jeep lockset came with door locks employing the lazy pawl.

Here's some good news from Adams Rite. A new top-rod-only vertical rod. For locksmiths, this eliminates the typical installation and adjustment problems caused by having the lower rod. The top rod uses a pitbull top bolt and strike that interlock.

For your customers, the unit is not only ADA compliant, it is also U.L. Listed for life safety and even comes with a limited fire rating. The unit is available as the 8100T for life safety applications and the 3100T with the fire rating. We'll try and bring you an installation a little later this year.

American Lock & Supply is offering a new handbook for locksmiths and security professionals called the "Security Professional Sales & Marketing Handbook." While our trade is filled with technical manuals for servicing autos, safes, and doors, very few have technical information on servicing the growth of a security business.

This manual directs the locksmith in business growth by addressing specific topics such as marketing plan development, corporate identity pieces, merchandising, direct mail, print and broadcast media, and sales tactics.

The manual can be purchased from American Lock & Supply at a cost of \$75 by calling 800-854-8775.

Dave Stone, CRL, of American Safe & Lock out of Lombard, Illinois sends in this tidbit. To work on the ignition of a 1990 Mazda Miata, the airbag, steering wheel and clockspring need to be removed.

According to Dave, the Miata has an energy reserve module to power the airbag even after the battery has been disconnected. Dave states that Mazda service procedure recommends disconnecting the battery and then turning on lights and depressing the brakes (to illuminate the brake lights) till the energy reserve module has been depleted, before servicing or removing the airbag.

During reinstallation it will be necessary to first center and sequence the clockspring and the steering wheel.

Thanks Dave. 



KEY CODES

Master Large Pin 1-3200

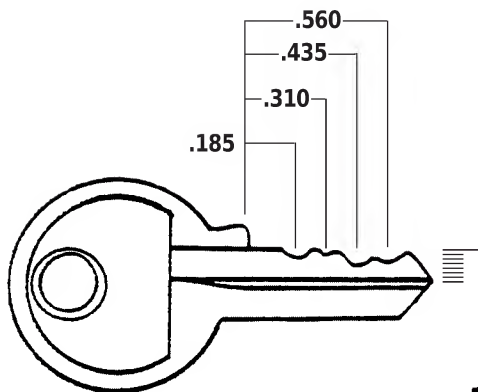

Depths	
0	0.275
1	0.260
2	0.245
3	0.230
4	0.215
5	0.200
6	0.185
7	0.170



HPC 1200 CM
Code Card - C35
Cutter - CW1011
Stop - Shoulder

Framon
Cut start - .187"
Cutter - FC8445
Cut to cut - .125",
Spacing Block #1
Stop - Shoulder

Key Blanks
Master 1K
Ilco 1092
Silca M52
Jet M1

Compatible Codes for this Chart

1-3000	10N1-1000
10T01-1000	2001-2750
34H601-1000	35H401-850
5001-5500	6001-6750
8001-8500	A101-2000
E1-700	J 2001-2150
J 3U00-J 5U49	U1-3250
W1-3500	X5001-5500
10L01-1000	10R01-18R00
1U0-25U9	3201-4000
35H251-300	4201-5000
5501-6000	7001-8000
9001-10000	A5501-6400
E2001-3000	J 301-1250
0301-950	USN1-600
X2001-3000	

1	0	36	0	71	0	106	0	141	0	176	0
2	0	37	0	72	0	107	0	142	0	177	0
3	0	38	0	73	0	108	0	143	0	178	0
4	0	39	0	74	0	109	3145	144	0	179	0
5	0	40	0	75	0	110	0	145	0	180	0
6	0	41	0	76	0	111	0	146	0	181	0
7	0	42	0	77	0	112	0	147	0	182	0
8	0	43	0	78	0	113	0	148	0	183	0
9	0	44	0	79	0	114	5156	149	0	184	0
10	0	45	0	80	0	115	0	150	0	185	0
11	0	46	0	81	0	116	2211	151	0	186	0
12	0	47	0	82	0	117	0	152	0	187	0
13	3610	48	0	83	0	118	0	153	0	188	0
14	1422	49	0	84	0	119	0	154	0	189	0
15	0	50	0	85	0	120	0	155	0	190	0
16	0	51	0	86	0	121	0	156	0	191	0
17	0	52	0	87	0	122	0	157	0	192	0
18	6321	53	0	88	0	123	0	158	0	193	0
19	0	54	0	89	0	124	0	159	0	194	0
20	0	55	0	90	0	125	0	160	0	195	0
21	0	56	0	91	0	126	0	161	0	196	0
22	0	57	0	92	0	127	0	162	0	197	0
23	0	58	1155	93	0	128	0	163	0	198	0
24	0	59	0	94	0	129	6214	164	0	199	4466
25	0	60	0	95	0	130	0	165	0	200	0
26	0	61	0	96	0	131	0	166	0	201	0
27	0	62	0	97	6241	132	0	167	0	202	0
28	0	63	0	98	6253	133	3463	168	0	203	0
29	0	64	0	99	6266	134	0	169	0	204	0
30	0	65	0	100	6314	135	0	170	0	205	6355
31	0	66	0	101	0	136	0	171	0	206	0
32	0213	67	0	102	0	137	0	172	0	207	0
33	0	68	0	103	0	138	0	173	0	208	0
34	0	69	0	104	0	139	0	174	0	209	0
35	0	70	0	105	0	140	0	175	0	210	0



Master Large Pin 1-3200

211	0	277	0	343	3266	409	4322	475	2534	541	2025
212	0	278	0	344	5442	410	4625	476	6355	542	3204
213	0	279	0	345	0421	411	3252	477	4254	543	4322
214	0	280	0	346	5434	412	3455	478	4652	544	3024
215	0	281	0	347	2666	413	5642	479	3454	545	4026
216	0	282	0	348	0	414	5354	480	5346	546	0
217	0	283	0	349	0	415	3545	481	4464	547	0
218	0	284	0	350	4434	416	4235	482	6412	548	2403
219	0	285	0	351	0431	417	6345	483	3634	549	0
220	0	286	0	352	0	418	5431	484	5452	550	0
221	0	287	0	353	2121	419	3354	485	5635	551	4203
222	0	288	0	354	3240	420	4413	486	4454	552	0
223	0	289	0	355	5421	421	6634	487	4522	553	6505
224	0	290	0	356	0362	422	3664	488	4346	554	2034
225	0	291	0	357	1202	423	5235	489	6443	555	0
226	0	292	0	358	4644	424	4263	490	3436	556	4402
227	0	293	0	359	2240	425	6326	491	3414	557	3402
228	0	294	0	360	0	426	4445	492	5355	558	3041
229	0	295	0	361	0456	427	3523	493	5644	559	4302
230	0	296	0	362	5311	428	3342	494	4432	560	4045
231	0	297	0	363	2054	429	5544	495	4036	561	6202
232	0	298	0	364	4230	430	6441	496	6415	562	3302
233	1565	299	0	365	0	431	5336	497	3435	563	2055
234	0	300	0	366	1142	432	4244	498	5343	564	2404
235	6355	301	6223	367	3120	433	4524	499	5522	565	4021
236	0	302	4554	368	0	434	5552	500	5413	566	0
237	0	303	0	369	0	435	2403	501	3345	567	6404
238	0	304	6223	370	3043	436	3413	502	6532	568	2043
239	0	305	0	371	0	437	5425	503	4553	569	3046
240	0	306	3640	372	1540	438	6362	504	3534	570	0
241	0	307	0	373	0	439	4355	505	5363	571	4033
242	0	308	0	374	0	440	3635	506	5626	572	2036
243	0	309	3403	375	0	441	5342	507	6545	573	2302
244	0	310	5220	376	5120	442	5645	508	4345	574	4202
245	0	311	1120	377	4130	443	6523	509	4563	575	0
246	0	312	4420	378	0254	444	3422	510	3336	576	2026
247	0	313	2114	379	3025	445	3564	511	3524	577	3503
248	0	314	5325	380	4330	446	5526	512	6534	578	0
249	0	315	0436	381	1133	447	6453	513	4552	579	6203
250	0	316	5302	382	5042	448	4456	514	5313	580	3202
251	0	317	2530	383	4531	449	3522	515	5454	581	0
252	0	318	0	384	4620	450	0	516	3424	582	0
253	0	319	0	385	0463	451	5415	517	6556	583	4143
254	0	320	4044	386	1156	452	4352	518	4421	584	3304
255	0	321	2212	387	5330	453	4521	519	6657	585	3044
256	0	322	4663	388	1340	454	3346	520	3433	586	3032
257	0	323	0315	389	5304	455	3554	521	6414	587	4403
258	0	324	5413	390	0341	456	6624	522	4453	588	4022
259	0	325	0	391	4414	457	6464	523	5233	589	3023
260	0	326	1222	392	1231	458	5244	524	3455	590	2024
261	0	327	4354	393	4203	459	5315	525	6444	591	6304
262	0	328	2330	394	0	460	3642	526	4342	592	3036
263	0	329	5411	395	0446	461	3265	527	5246	593	4303
264	0	330	0426	396	3231	462	3515	528	3335	594	2203
265	0	331	1123	397	4465	463	4332	529	6513	595	4036
266	0	332	3520	398	0121	464	4646	530	4433	596	0
267	0	333	6241	399	0344	465	6452	531	5455	597	0
268	0	334	0	400	3632	466	5364	532	3442	598	2032
269	0	335	3365	401	3364	467	5423	533	4334	599	0
270	0	336	5424	402	5334	468	3563	534	6643	600	0
271	0	337	0232	403	6551	469	4225	535	5436	601	0
272	0	338	5352	404	4542	470	4662	536	3453	602	2023
273	0	339	2130	405	4112	471	6436	537	5643	603	6302
274	0	340	5464	406	3426	472	3464	538	5242	604	4024
275	0	341	1641	407	5344	473	5443	539	6542	605	0
276	0	342	1153	408	6522	474	5414	540	4323	606	3031



Master Large Pin

1-3200

607	0	673	6303	739	0	805	0	871	0	937	0
608	0	674	0245	740	1144	806	1433	872	3035	938	4664
609	2024	675	5333	741	6403	807	0	873	1240	939	0366
610	4120	676	0	742	3130	808	5611	874	3620	940	0
611	4425	677	3630	743	0	809	1234	875	0	941	4366
612	2033	678	6622	744	0326	810	4211	876	0	942	0332
613	6344	679	0	745	6320	811	0	877	4341	943	1124
614	3326	680	5253	746	3033	812	2554	878	6303	944	3530
615	1214	681	2140	747	6230	813	4035	879	2042	945	5565
616	4546	682	5531	748	0	814	4547	880	4333	946	0332
617	6413	683	0356	749	4111	815	0311	881	0225	947	4566
618	3533	684	3466	750	2213	816	0	882	5230	948	3021
619	2045	685	5320	751	0444	817	2044	883	2402	949	0
620	3211	686	0	752	3051	818	4466	884	5140	950	2465
621	0	687	2413	753	5366	819	0	885	0566	951	0
622	0236	688	0441	754	1303	820	4433	886	1203	952	0
623	0	689	0	755	0	821	4212	887	0	953	0
624	2630	690	0	756	3331	822	1364	888	2340	954	0
625	2013	691	5435	757	6520	823	5456	889	5520	955	0
626	1402	692	0226	758	0352	824	0342	890	0242	956	0
627	3555	693	0	759	1320	825	4404	891	3430	957	0
628	2013	694	3303	760	0	826	2430	892	5554	958	0
629	0412	695	4640	761	3245	827	0	893	0	959	0
630	4656	696	0	762	2303	828	6530	894	5402	960	0
631	0	697	6552	763	0	829	0	895	2122	961	0
632	0	698	2320	764	0241	830	4426	896	0	962	0
633	0	699	6540	765	4041	831	6644	897	0351	963	0
634	3511	700	0415	766	5430	832	0434	898	1145	964	0
635	5340	701	5202	767	1404	833	1125	899	3566	965	0
636	0321	702	3340	768	4034	834	3556	900	6340	966	0
637	5322	703	6632	769	6631	835	0	901	0	967	0
638	1241	704	2213	770	0443	836	0	902	5563	968	0
639	5464	705	4023	771	4113	837	2452	903	0263	969	0
640	0465	706	0	772	2540	838	0354	904	2121	970	0
641	5524	707	1211	773	6663	839	0	905	4042	971	0
642	0	708	5404	774	2426	840	0	906	5440	972	0
643	4311	709	0347	775	4131	841	5655	907	2751	973	0
644	5462	710	5640	776	2262	842	0	908	6555	974	0
645	0364	711	1126	777	5203	843	4031	909	1440	975	0
646	5630	712	3244	778	2152	844	5266	910	0312	976	0
647	3203	713	4511	779	1312	845	0425	911	3320	977	0
648	5663	714	1430	780	3565	846	1132	912	0	978	0
649	2031	715	3444	781	5134	847	4520	913	1330	979	0
650	0	716	4340	782	1520	848	1420	914	2041	980	0
651	6204	717	0363	783	4025	849	3446	915	2304	981	0
652	0246	718	0421	784	3225	850	4430	916	5620	982	0
653	5112	719	3034	785	0365	851	0345	917	0435	983	0
654	5542	720	5444	786	0	852	3140	918	5540	984	0
655	4445	721	0	787	2230	853	0	919	2420	985	0
656	5120	722	1155	788	2436	854	2035	920	0	986	0
657	5556	723	3220	789	0	855	5654	921	1304	987	0
658	0444	724	6636	790	4320	856	0451	922	0	988	0
659	0313	725	0323	791	2313	857	0	923	0215	989	0
660	4304	726	3553	792	0	858	3465	924	4240	990	0
661	2440	727	5664	793	0164	859	0212	925	2112	991	0
662	6220	728	2204	794	1230	860	0	926	0	992	0
663	0	729	3440	795	0553	861	4655	927	3420	993	0
664	0	730	4123	796	3042	862	1403	928	0343	994	0
665	3036	731	5466	797	5511	863	3045	929	3443	995	0
666	6311	732	3311	798	2231	864	4121	930	5420	996	0
667	0411	733	5356	799	4320	865	0423	931	1530	997	0
668	1146	734	0432	800	5525	866	1136	932	4220	998	5126
669	4032	735	4665	801	2520	867	4530	933	5356	999	0
670	6512	736	2041	802	6211	868	4410	934	1122	1000	0
671	0	737	4204	803	0324	869	4630	935	0		
672	3540	738	5551	804	6553	870	7234	936	2232		



BEGINNER'S CORNER

Continued from page 48

lock problem. This was securing a maintenance storage building. The building had been secured with a high security padlock, but smart burglars had cut the small sized hasp and had absconded with the lock plus tools and a generator. This building has two large doors, each four feet wide, that swing together. I removed what was left of the old hasp, and installed a thick, large, heavy, what I call a barn door, hasp. The hasp was installed with bolts and one way screws. I removed some of the screws from the hinges, and replaced them with bolts and one way screws.



4. This large hasp and round padlock were used to protect this shed.

For additional security I drilled a hole in the door edge on the hinge side, then put a metal pin on the jamb side, similar to the protection safes have. If someone does manage to tear the hinges off, the doors still will not open.

Finishing off the security was a round Abus 24 padlock. Burglars should have a tough time getting into this building now. (See photograph 4.)



LIGHTER SIDE

Continued from page 86

"Don't worry about it. Just come into the store and buy something, some time, and we'll call it even."

John proffered a twenty dollar bill. "Here. Take this."

"I didn't do anything to earn it," Don insisted.

"What do you mean, you didn't do anything? Man, you probably saved my life! When Molly found out I'd locked the keys up in her new car, and

we couldn't find a spare, there was murder in her eyes. Just knowing you were on your way and could get the car open without tearing it up saved my marriage, at the least. It may have saved my hide! Here." John stuffed the bill into Don's shirt pocket. "And I'll be in on Monday to get duplicates made of every key I own. I've been meaning to do it for years, and just never got around to it. Well, I'll never be caught like this again. If I can get that old safe in the basement open, I'm gonna start keeping all my keys there, for emergencies. Man, I learned my lesson today."

When Don told me about this, I couldn't help laughing.

"This may only be the beginning of his problems," I said. "How long do you suppose it's been since he's had his safe serviced?"



THRU THE KEYHOLE

Continued from page 96

Locksmiths still can count on training seminars at trade shows, or from company field representatives and distributors. Also, locksmiths coming across locks they're not familiar with can still call the company for necessary information and guidance.

As stated earlier, the Big Three automakers still rely on the company, supplying locks, keys and latches to the production lines of General Motors, Chrysler and Ford. Locksmiths, too, can still depend on STRATTEC to continue to manufacture replacement locks, keys, components and service kits for Chrysler, Ford and General Motors. Lock service packages and parts also will be produced for Freightliner, Kenworth, Mack, Navistar, Peterbilt and GM Volvo White trucks. Replacement parts include key blanks,



3. Briggs & Stratton Technologies is one of only 17 suppliers in the world to win two major quality awards from the automotive industry in the same year.

tumblers, caps and shutters, and other components.

Also, like Briggs & Stratton Technologies, STRATTEC will supply locks and keys for boats and recreation vehicles, as well as continue to provide switches, push-button hook-bolt and bolt-in-case style latches, non-locking latches, and water-resistant cam locks, as well as attaching hardware. Components such as key blanks, tumblers and caps and shutters also will be produced.

The History

The name is new, but the company has more than 85 years of experience in the automotive industry. Locks and ignition switches were among the first products made by Briggs & Stratton, formed in 1909, and helped ensure the company's success during its early years. Despite manufacturing a variety of other products during the past 85 years, locks made the division a cornerstone of the company.

During the past 10 years, the lock division's engineering department tripled in size. The design and testing needed to produce better locks advanced to the point that the division was named Briggs & Stratton Technologies in 1987 to

NATIONAL
AUTO LOCK SERVICE, INC.

National Auto Lock Service, Inc. offers a wide range of equipment and services for the Automotive Locksmith. From tools and hard to find key blanks to transponder programming, we can take the mystery out of car service. We accept credit card orders, and can ship COD. Contact us for the latest in automotive technology.

www.laserkey.com

more appropriately reflect its capabilities.

Today, auto manufacturers don't just provide specifications for manufacturing, they increasingly rely on the company to design and engineer lock systems.

For example, it was Briggs & Stratton that helped develop the VATS/PASSKEY ignition lock, introduced on the 1986 Corvette. The lock used both mechanical and electronic features to improve vehicle security. The system proved its effectiveness, reducing Corvette thefts by 45 percent. It is now used on 26 different GM models and is certain to become standard equipment on many more.

Quality has always been an important part of the business. Locks are subjected to extreme temperatures, severe humidity, dust, steam, high-pressure water sprays, torque, heavy impact, and a slam-pull test that duplicates a method commonly used by thieves to defeat locks.

This means more than just having

rooms full of impressive looking test equipment. It means the locks will stand up to the heat of California's Death Valley, the long, harsh winters of the Midwest, dust storms in Arizona, the heavy rains in the Pacific Northwest, and harsh car washes everywhere.

The top priority placed on quality earned Briggs & Stratton Technologies the GM QSP Worldwide Supplier Award and the Chrysler Platinum Pentastar Award last year. (See photograph 3.) Those achievements made Briggs & Stratton Technologies one of an elite class of 17 suppliers in the world to win two major quality awards from the automotive industry in the same year. STRATTEC SECURITY CORP. will uphold those standards so locksmiths can continue to give their customers high-quality, serviceable products. 

TECHNITIPS

Continued from page 105

Join Roadside Assistance

 I found an article in the February,

1994 issue of Consumers Digest that told about the roadside assistance programs (particularly lost key replacement and lock out service) being offered by BMW, Chevrolet, Pontiac, Cadillac, Oldsmobile and Ford Motor Co. The article also mentioned that these services were available through AAA, Allstate and the Ammoco Motor Club.

I thought that this might be a good source of business for locksmiths that wanted to contact these companies.

Len Wagner
Illinois.

Spring Cover Replacement

 Have you ever lost the cylinder cap retaining pin screw in a Schlage or Weiser cylinder, only to find you did not have a replacement?

When this happened to me recently, I found that cylinder spring from my G.M. pinning kit worked very well as a substitute. Since then, I have used this "trick" on several occasions.

Joe Stofferahnt
Minnesota



The Innovation You Expect, with the
Flexibility You Need!

[Click here for more information](#)

TEST DRIVE



Taking Industry Products for a Spin Around the Block

THE HPC BLITZ™

PRODUCT: The Blitz™ and the Blitz™ upgrade by HPC. The Blitz™ machine is available from HPC Distributors for a suggested dealer price of \$2,099.00. Pricing for the complete upgrade (which includes the new style Flip-Gauge, Softie™ Brush and Depth and Space Accelerators) is \$125. In addition, HPC includes a free cleaning, factory adjustment and prepaid shipping with the complete upgrade.

You may also choose to upgrade only a portion of your machine. The cost of the Depth and Space Accelerator is \$75; the Flip-Gauge is \$25; and the Softie™ Brush with shield is \$40. The Flip-Gauge and the Softie™ Brush installation may also be performed by the locksmith; however, the Depth and Space Accelerators can only be performed by an Authorized HPC Service Center. To find the Authorized HPC Service Center near you, contact HPC, Inc. P.O. Box 2093, Schiller Park, IL 60176-2093, 708-671-6280.

PRODUCT DESCRIPTION: The Blitz™ and Blitz™ upgrade are design enhancements made to the 1200CM to increase the speed with which a key can be cut.

Included is a Softie™ Brush for finishing just cut keys, and the Flip-Gauge for faster retrieval of the shoulder stop.

Most noticeable, however, is the Depth and Space Accelerator, that drastically increases the travel speed of the key across the cutter.

FRIENDLINESS: The friendliness of the 1200 is not affected by the upgrade. Keys are still cut using the easy to read 1200CM code cards.

Upgrading can be performed on any 1200CM machine manufactured

after December 1983. If a locksmith has a question regarding the manufacturing date of his machine, contact HPC for assistance.

Knowing locksmiths cannot be without their machine for long, HPC has developed a process for quick return on the Blitz™ conversion.



The Blitz™ conversion, offering Flip Gauge, Softie Brush™ and a Depth and Space Accelerator.

Before a machine is sent in, the locksmith must submit an upgrade ticket in order to receive an appointment. (Upgrade Tickets are available from HPC and HPC distributors.) Once the appointment is made, all machines scheduled to arrive on a Friday are shipped out by the following Tuesday.

FEATURES: The Softie™ Brush is a nice addition, and is attached to the motor's drive shaft. While not actually increasing the cutting speed of a key, it's no longer necessary to turn on another machine to finish a just cut key.

The Flip-Gauge is also a pleasant convenience, that can decrease the amount of time it takes to cut a group of keys. A long arm attached to the

DESCRIPTION:
HPC's Blitz™ and Blitz™ upgrade.

COMMENTS:
The Blitz™ provided a substantial increase in key generation with few drawbacks.

TEST DRIVE RESULTS:
The time and money invested is easily justified by the faster cutting speeds and design enhancements offered by the Blitz™.

shoulder stop allows for fast easy retrieval of the stop for quick placement of a key in the jaws. Plus, the red aluminum Flip-Gauge serves as a red flag, making you aware that the shoulder stop has been left up.

The heart of the Blitz™, however, is the new Depth and Speed drive gears. The Blitz™ Depth crank covers the same amount of travel in 2.5 rotations as it takes the standard 1200CM 12 rotations to cover. Almost a 1 to 5 ratio.

The Blitz™ Spacing crank makes the same travel in 4 turns that it took the standard 1200CM 14 turns to make. That's a 1 to 3.5 ratio.

COMMENTS AND SUGGESTIONS: After a few trial runs to get used to the machine, the increase in cutting speed was extraordinary.

CONCLUSION: It's hard to improve on a piece of equipment like the 1200CM. However, the Blitz™ upgrade truly rounds out what has already been a tried and true performer. The small investment necessary to upgrade a 1200CM is well worth it!

