

REV	DESCRIPTION	DATE	APPROVED
-----	-------------	------	----------

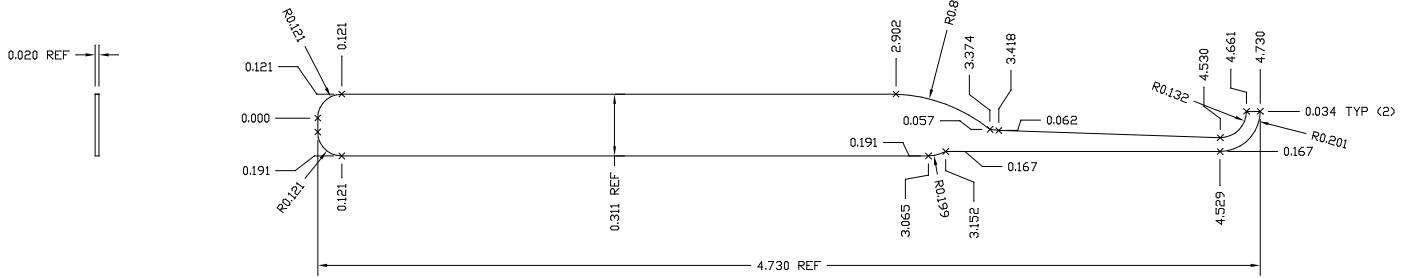

\*\*\*\*\*THIS VIEW IS 1d ONLY WHEN PRINTED  
IN 11X17 PAPER\*\*\*\*\*



\*\*\*\*\*THIS VIEW IS 1d ONLY WHEN PRINTED  
IN 11X17 PAPER\*\*\*\*\*

NOTES:  
-CAD FILES AVAILABLE WITH ORDER.  
-ACAD 2000 DWG OR ACAD DXF PROVIDED.  
-CAD FILE IN MAIN VIEW IS DRAWN 1:1.  
-BORDER IS SCALED TO PRINT.  
-LAYER TO CUT CALLED "PICK"

MOCK-UP QTY: 30  
PROD QTY: 2500

MATL: 1095 STEEL  
MATL CERTS REQUIRED  
FINISH: TUMBLE DEBUR

OPEN  
LOCK PICK SET  
PICK BLADE

TOLERANCES:  
X.XXX +/- 0.005"  
FRACTIONS +/- 1/64"  
ANGLES +/- 1/2

DATE: 5-18-2011

SIZE SCALE  
B 2:1

REV. DWG NO.  
ISON-1016-01-01

REV	DESCRIPTION	DATE	APPROVED
-----	-------------	------	----------

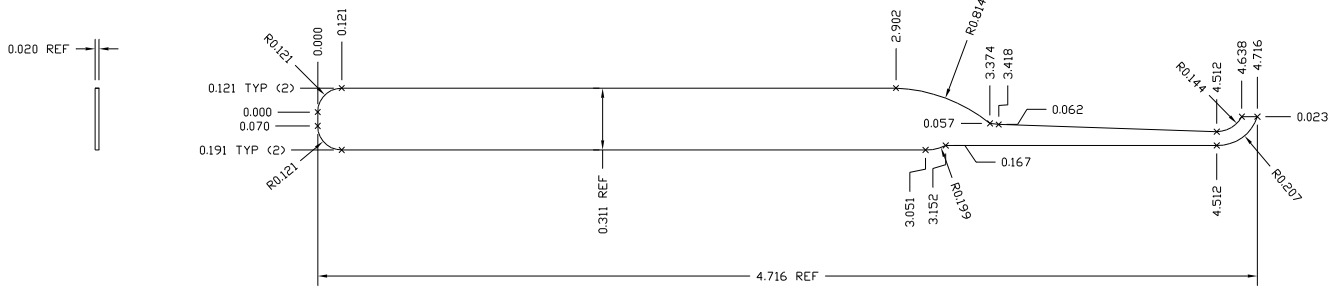

\*\*\*\*\*THIS VIEW IS 1:1 ONLY WHEN PRINTED  
ON 11X17 PAPER\*\*\*\*\*

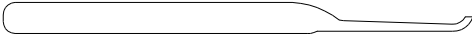

\*\*\*\*\*THIS VIEW IS 1:1 ONLY WHEN PRINTED  
ON 11X17 PAPER\*\*\*\*\*

NOTES:  
-CAD FILES AVAILABLE WITH ORDER.  
-ACAD 2000 DWG OR ACAD DXF PROVIDED.  
-CAD FILE IN MAIN VIEW IS DRAWN 1:1.  
-BORDER IS SCALED TO PRINT.  
-LAYED TO CUT IS CALLED "PICK"

MOCK UP QTY: 30  
PROD QTY: 2500

MATL: 1095  
MATL CERTS REQUIRED  
FINISH: DEBUR, TUMBLE

OPEN  
LOCK PICK SET  
PICK BLADE

TOLERANCES:  
X.XXX +/- 0.005"  
FRACTIONS +/- 1/64"  
ANGLES +/- 1/2

DATE: 5-18-2011

SIZE	SCALE	REV.	DWG NO.
B	2:1		ISON-1016-01-02

REV	DESCRIPTION	DATE	APPROVED
-----	-------------	------	----------

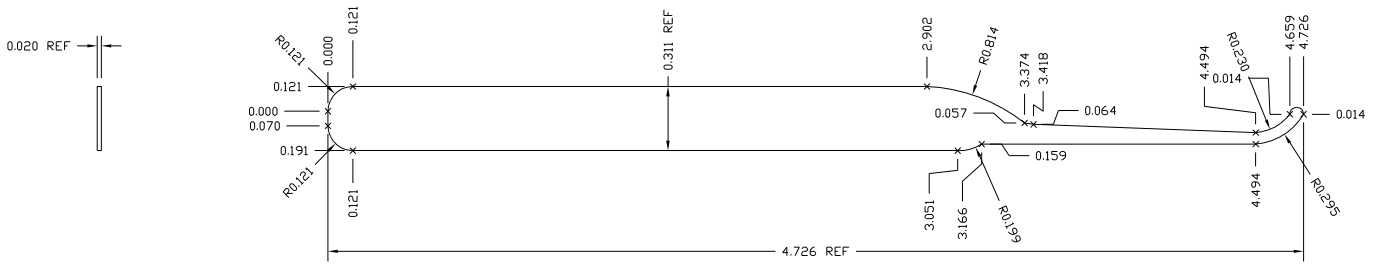

\*\*\*\*\*THIS VIEW IS 1:1 ONLY WHEN PRINTED ON 11X17 PAPER\*\*\*\*\*

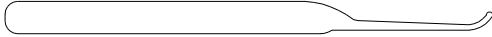

\*\*\*\*\*THIS VIEW IS 1:1 ONLY WHEN PRINTED ON 11X17 PAPER\*\*\*\*\*

NOTES:  
 -CAD FILES AVAILABLE WITH ORDER.  
 -ACAD 2000 DWG OR ACAD DXF PROVIDED.  
 -CAD FILE IN MAIN VIEW IS DRAWN 1:1.  
 -BORDER IS SCALED TO PRINT.  
 -LAYED TO CUT IS CALLED "PICK"

MOCK UP QTY: 30 PROD QTY: 2500		OPEN LOCK PICK SET PICK BLADE	
MATERIAL: 1095 STEEL MATERIAL CERTS REQUIRED FINISH: DEBUR, TUMBLE		DATE: 5-18-2011	
TOLERANCES: X.XXX +/- 0.005" FRACTIONS +/- 1/64" ANGLES +/- 1/2		SIZE B	SCALE 2:1
		REV.	DWG NO. ISON-1016-01-03

REV	DESCRIPTION	DATE	APPROVED
-----	-------------	------	----------

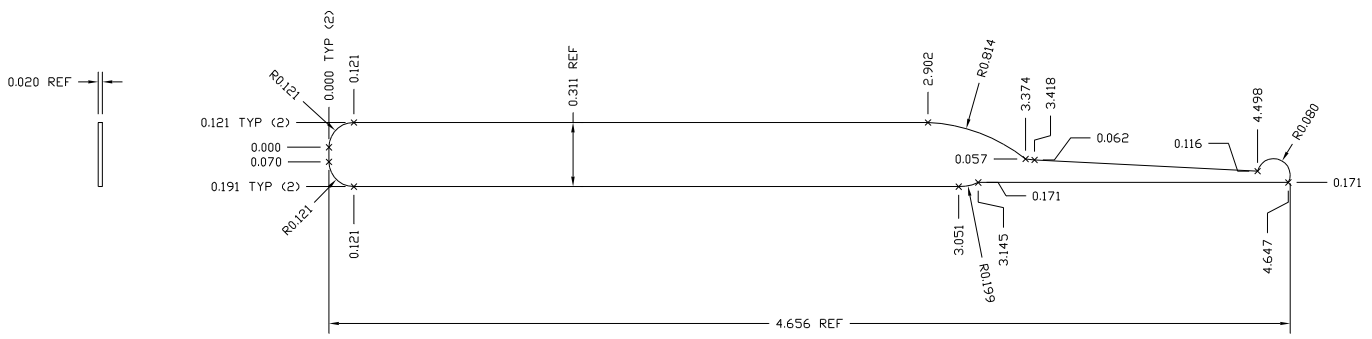

\*\*\*\*\*THIS VIEW IS 1:1 ONLY WHEN PRINTED ON 11X17 PAPER\*\*\*\*\*

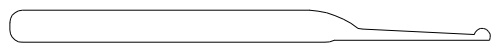

\*\*\*\*\*THIS VIEW IS 1:1 ONLY WHEN PRINTED ON 11X17 PAPER\*\*\*\*\*

NOTES:  
 -CAD FILES AVAILABLE WITH ORDER.  
 -ACAD 2000 DWG OR ACAD DXF PROVIDED.  
 -CAD FILE IN MAIN VIEW IS DRAWN 1:1.  
 -BORDER IS SCALED TO PRINT.  
 -LAYER TO CUT IS CALLED "PICK"

MOCK UP QTY: 30 PROD QTY: 2500		OPEN LOCK PICK SET PICK BLADE	
MATERIAL: 1095 STEEL MATERIAL CERTS REQUIRED FINISH: DEBUR, TUMBLE		DATE: 5-18-2011	DWG NO. ISON-1016-01-04
TOLERANCES: X.XXX +/- 0.005" FRACTIONS +/- 1/64" ANGLES +/- 1/2		SIZE: B	SCALE: 2:1

REV	DESCRIPTION	DATE	APPROVED
-----	-------------	------	----------

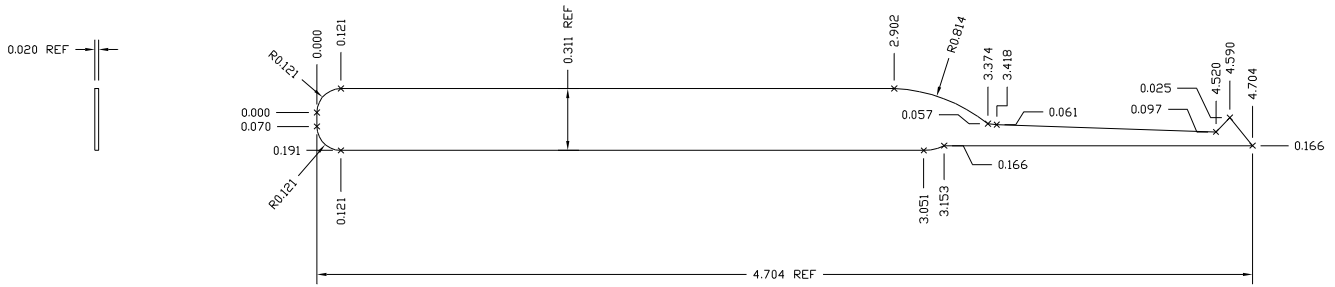

\*\*\*\*\*THIS VIEW IS 1:1 ONLY WHEN PRINTED  
ON 11X17 PAPER\*\*\*\*\*

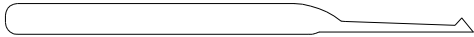

\*\*\*\*\*THIS VIEW IS 1:1 ONLY WHEN PRINTED  
ON 11X17 PAPER\*\*\*\*\*

NOTES:  
-CAD FILES AVAILABLE WITH ORDER.  
-ACAD 2000 DWG OR ACAD DXF PROVIDED.  
-CAD FILE IN MAIN VIEW IS DRAWN 1:1.  
-BORDER IS SCALED TO PRINT.  
-LAYED TO CUT IS CALLED "PICK"

MOCK UP QTY: 30  
PROD QTY: 2500

MATL: 1095 STEEL  
MATL CERTS REQUIRED  
FINISH: DEBUR, TUMBLE

OPEN  
LOCK PICK SET  
PICK BLADE

TOLERANCES:  
X.XXX +/- 0.005"  
FRACTIONS +/- 1/64"  
ANGLES +/- 1/2

DATE: 5-18-2011

SIZE	SCALE	REV.	DWG NO.
B	2:1		ISON-1016-01-05

DWG NO.  
ISON-1016-01-05

REV	DESCRIPTION	DATE	APPROVED
-----	-------------	------	----------

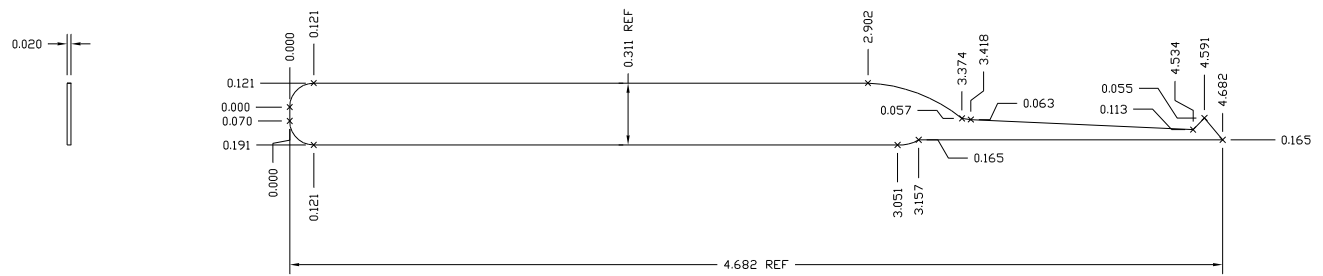

\*\*\*\*\*THIS VIEW IS 1:1 ONLY WHEN PRINTED  
ON 11X17 PAPER\*\*\*\*\*



\*\*\*\*\*THIS VIEW IS 1:1 ONLY WHEN PRINTED  
ON 11X17 PAPER\*\*\*\*\*

NOTES:  
 -CAD FILES AVAILABLE WITH ORDER.  
 -ACAD 2000 DWG OR ACAD DXF PROVIDED.  
 -CAD FILE IN MAIN VIEW IS DRAWN 1:1.  
 -BORDER IS SCALED TO PRINT.  
 -LAYED TO CUT IS CALLED "PICK"

MOCK UP QTY: 30 PROD QTY: 2500		OPEN LOCK PICK SET PICK BLADE	
MATERIAL: 1095 STEEL MATERIAL CERTS REQUIRED FINISH: DEBUR, TUMBLE		DATE: 5-18-2011	
TOLERANCES: X.XXX +/- 0.005" FRACTIONS +/- 1/64" ANGLES +/- 1/2		SIZE B	SCALE 2:1
		REV.	DWG NO. ISON-1016-01-06

REV	DESCRIPTION	DATE	APPROVED
-----	-------------	------	----------

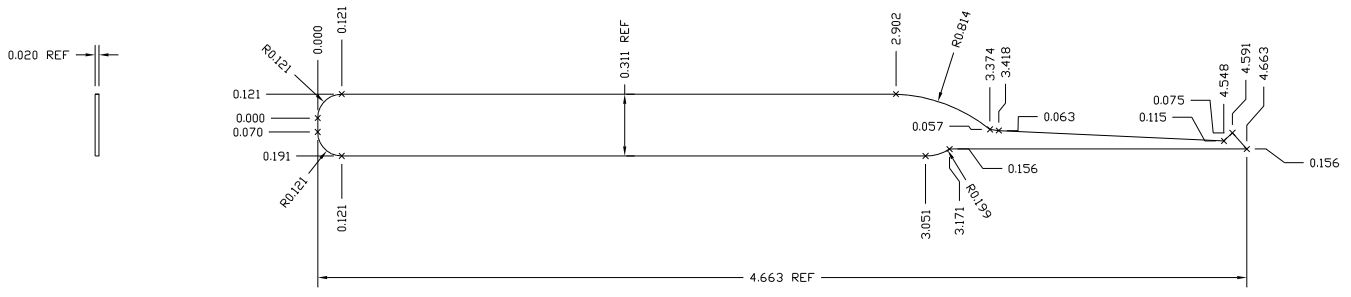

\*\*\*\*\*THIS VIEW IS 1:1 ONLY WHEN PRINTED  
ON 11X17 PAPER\*\*\*\*\*



\*\*\*\*\*THIS VIEW IS 1:1 ONLY WHEN PRINTED  
ON 11X17 PAPER\*\*\*\*\*

NOTES:  
-CAD FILES AVAILABLE WITH ORDER.  
-ACAD 2000 DWG OR ACAD DXF PROVIDED.  
-CAD FILE IN MAIN VIEW IS DRAWN 1:1.  
-BORDER IS SCALED TO PRINT.  
-LAYED TO CUT IS CALLED "PICK"

MOCK UP QTY: 30 PROD QTY: 2500		OPEN LOCK PICK SET PICK BLADE	
MATERIAL: 1095 STEEL MATERIAL CERTS REQUIRED FINISH: DEBUR, TUMBLE		DATE: 5-18-2011	
TOLERANCES: X.XXX +/- 0.005" FRACTIONS +/- 1/64" ANGLES +/- 1/2		SIZE B	SCALE 2:1
		REV.	DWG NO. ISON-1016-01-07

REV	DESCRIPTION	DATE	APPROVED
-----	-------------	------	----------

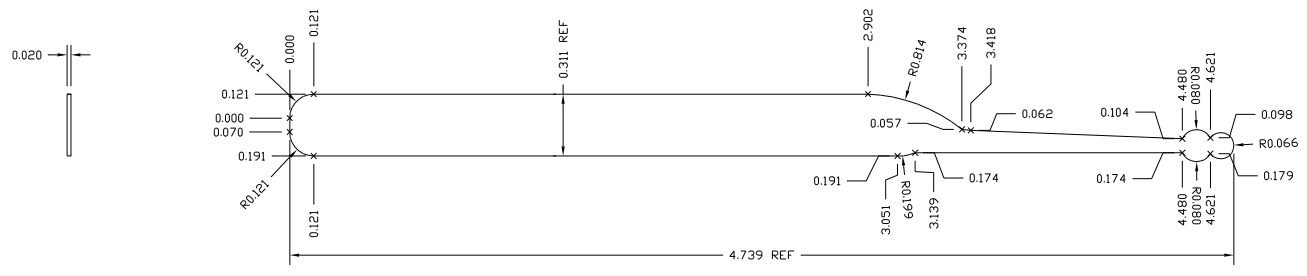

\*\*\*\*\*THIS VIEW IS 1:1 ONLY WHEN PRINTED  
ON 11X17 PAPER\*\*\*\*\*



\*\*\*\*\*THIS VIEW IS 1:1 ONLY WHEN PRINTED  
ON 11X17 PAPER\*\*\*\*\*

NOTES:  
-CAD FILES AVAILABLE WITH ORDER.  
-ACAD 2000 DWG OR ACAD DXF PROVIDED.  
-CAD FILE IN MAIN VIEW IS DRAWN 1:1.  
-BORDER IS SCALED TO PRINT.  
-LAYED TO CUT IS CALLED "PICK"

MOCK UP QTY: 30 PROD QTY: 2500		OPEN LOCK PICK SET PICK BLADE	
MATERIAL: 1095 STEEL MATERIAL CERTS REQUIRED FINISH: DEBUR, TUMBLE		DATE: 5-18-2011	
TOLERANCES: X.XXX +/- 0.005" FRACTIONS +/- 1/64" ANGLES +/- 1/2		SIZE B	SCALE 2:1
		REV.	DWG NO. ISON-1016-01-08



REV	DESCRIPTION	DATE	APPROVED
A	CHANGE PROFILE	6-11-2011	

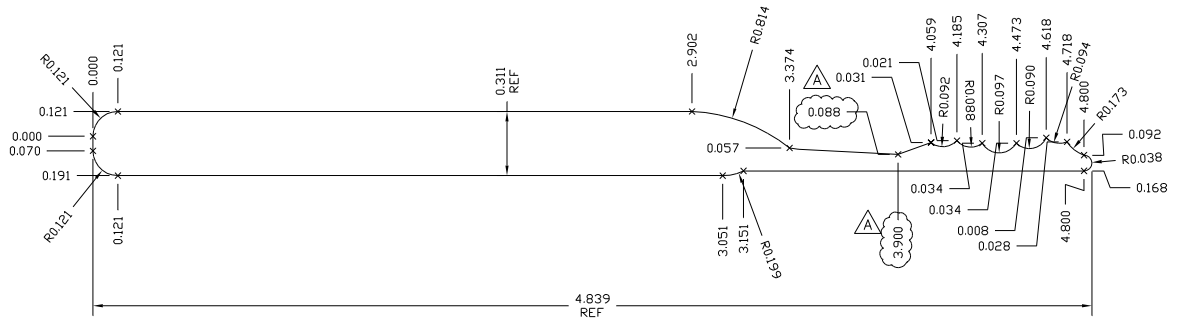
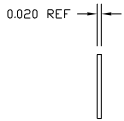

\*\*\*\*\*THIS VIEW IS 1:1 ONLY WHEN PRINTED ON 11X17 PAPER\*\*\*\*\*



\*\*\*\*\*THIS VIEW IS 1:1 ONLY WHEN PRINTED ON 11X17 PAPER\*\*\*\*\*

NOTES:  
 -CAD FILES AVAILABLE WITH ORDER.  
 -ACAD 2000 DWG OR ACAD DXF PROVIDED.  
 -CAD FILE IN MAIN VIEW IS DRAWN 1:1.  
 -BORDER IS SCALED TO PRINT.  
 -LAYED TO CUT IS CALLED "PICK"

MOCK UP QTY: 30 PROD QTY: 2500		OPEN LOCK PICK SET PICK BLADE	
MATERIAL: 1095 STEEL MATERIAL CERTS REQUIRED FINISH: DEBUR, TUMBLE		DATE: 5-18-2011	
TOLERANCES: X.XXX +/- 0.005" FRACTIONS +/- 1/64" ANGLES +/- 1/2		SIZE B	SCALE 2:1
		REV. A	DWG NO. ISON-1016-01-09



REV	DESCRIPTION	DATE	APPROVED
-----	-------------	------	----------

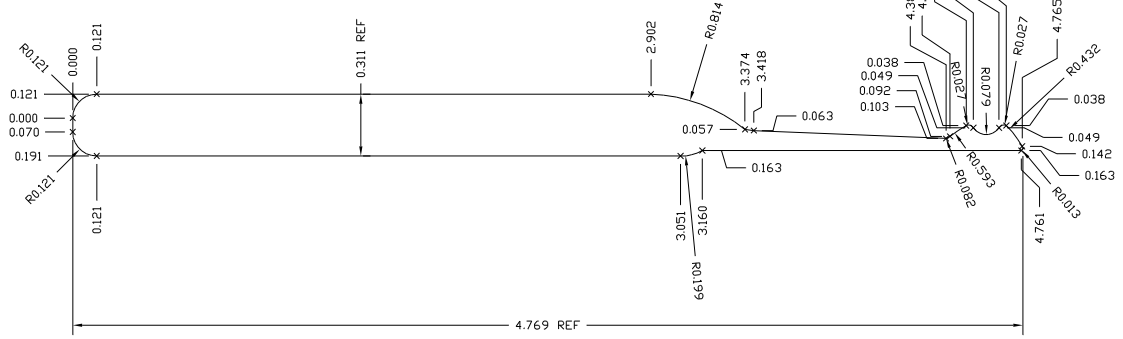
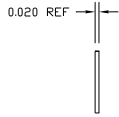

\*\*\*\*\*THIS VIEW IS 1:1 ONLY WHEN PRINTED  
ON 11X17 PAPER\*\*\*\*\*

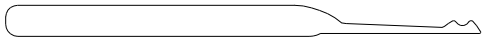

\*\*\*\*\*THIS VIEW IS 1:1 ONLY WHEN PRINTED  
ON 11X17 PAPER\*\*\*\*\*

- NOTES:  
 -CAD FILES AVAILABLE WITH ORDER.  
 -ACAD 2000 DWG OR ACAD DXF PROVIDED.  
 -CAD FILE IN MAIN VIEW IS DRAWN 1:1.  
 -BORDER IS SCALED TO PRINT.  
 -LAYED TO CUT IS CALLED "PICK"

MOCK UP QTY: 30 PROD QTY: 2500		OPEN LOCK PICK SET PICK BLADE	
MATERIAL: 1095 STEEL MATERIAL CERTS REQUIRED FINISH: DEBUR, TUMBLE		DATE: 5-18-2011	
TOLERANCES: X.XXX +/- 0.005" FRACTIONS +/- 1/64" ANGLES +/- 1/2		SIZE B	SCALE 2:1
		REV.	DWG NO. ISON-1016-01-11



REV	DESCRIPTION	DATE	APPROVED
-----	-------------	------	----------

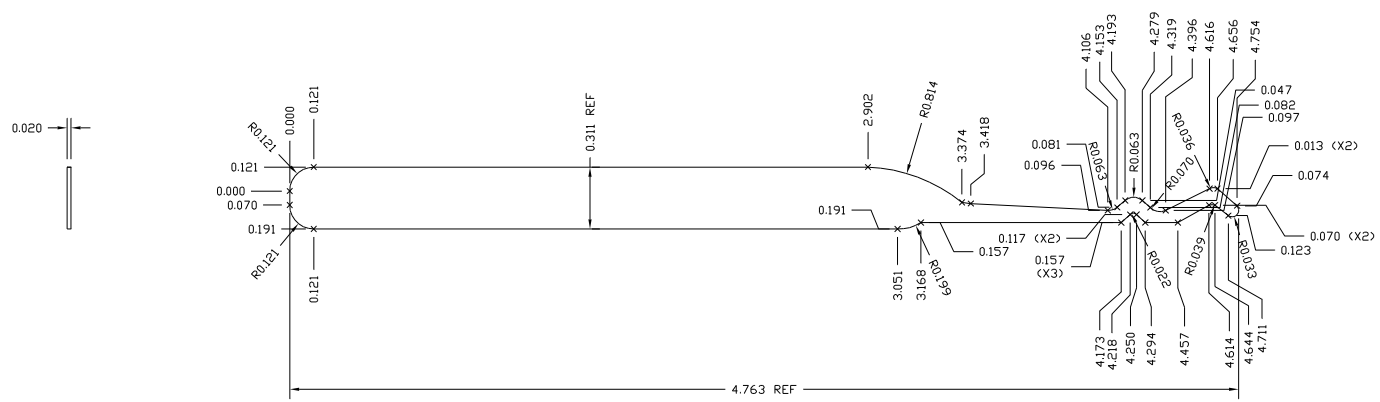

\*\*\*\*\*THIS VIEW IS 1:1 ONLY WHEN PRINTED  
ON 11X17 PAPER\*\*\*\*\*

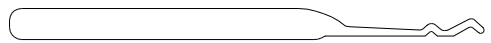

\*\*\*\*\*THIS VIEW IS 1:1 ONLY WHEN PRINTED  
ON 11X17 PAPER\*\*\*\*\*

NOTES:  
-CAD FILES AVAILABLE WITH ORDER.  
-ACAD 2000 DWG OR ACAD DXF PROVIDED.  
-CAD FILE IN MAIN VIEW IS DRAWN 1:1.  
-BORDER IS SCALED TO PRINT.  
-LAYED TO CUT IS CALLED "PICK"

MOCK UP QTY: 30  
PROD QTY: 2500

MATL: 1095 STEEL  
MATL CERTS REQUIRED  
FINISH: DEBUR, TUMBLE

TOLERANCES:  
X.XXX +/- 0.005"  
FRACTIONS +/- 1/64"  
ANGLES +/- 1/2

OPEN  
LOCK PICK SET  
PICK BLADE

DATE: 5-18-2011

SIZE	SCALE	REV.	DWG NO.
B	2:1		ISON-1016-01-13

REV	DESCRIPTION	DATE	APPROVED
-----	-------------	------	----------

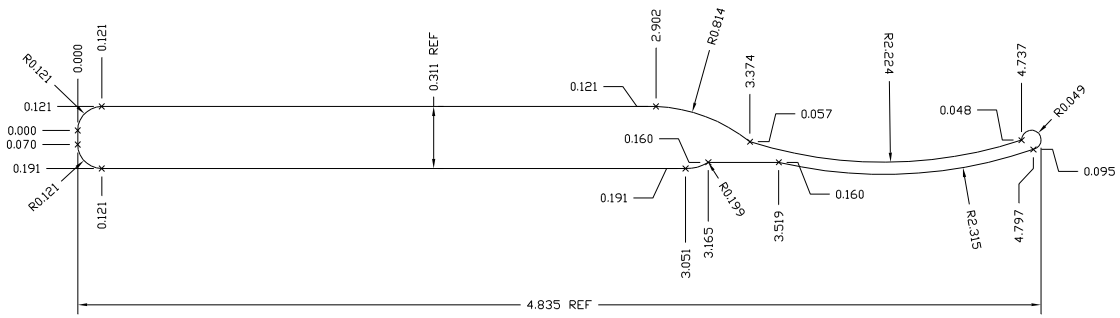
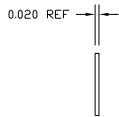

\*\*\*\*\*THIS VIEW IS 1:1 ONLY WHEN PRINTED  
ON 11X17 PAPER\*\*\*\*\*



\*\*\*\*\*THIS VIEW IS 1:1 ONLY WHEN PRINTED  
ON 11X17 PAPER\*\*\*\*\*

NOTES:  
-CAD FILES AVAILABLE WITH ORDER.  
-ACAD 2000 DWG OR ACAD DXF PROVIDED.  
-CAD FILE IN MAIN VIEW IS DRAWN 1:1.  
-BORDER IS SCALED TO PRINT.  
-LAYED TO CUT IS CALLED "PICK"

MOCK UP QTY: 30  
PROD QTY: 2500

MATL: 1095 STEEL  
MATL CERTS REQUIRED  
FINISH: DEBUR, TUMBLE

TOLERANCES:  
X.XXX +/- 0.005"  
FRACTIONS +/- 1/64"  
ANGLES +/- 1/2

OPEN  
LOCK PICK SET  
PICK BLADE

DATE: 5-18-2011

SIZE	SCALE	REV.	DWG NO.
B	2:1	A	ISON-1016-01-14

REV	DESCRIPTION	DATE	APPROVED
-----	-------------	------	----------

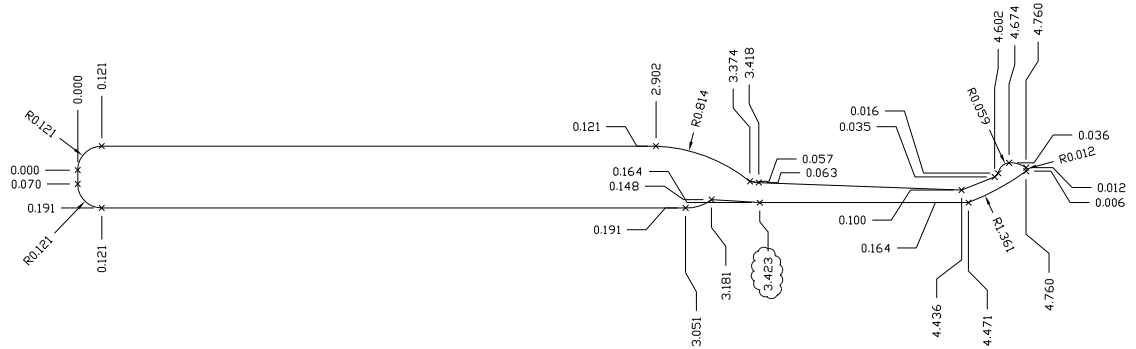
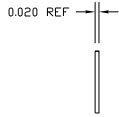

\*\*\*\*\*THIS VIEW IS 1:1 ONLY WHEN PRINTED  
ON 11X17 PAPER\*\*\*\*\*



\*\*\*\*\*THIS VIEW IS 1:1 ONLY WHEN PRINTED  
ON 11X17 PAPER\*\*\*\*\*

NOTES:  
-CAD FILES AVAILABLE WITH ORDER.  
-ACAD 2000 DWG OR ACAD DXF PROVIDED.  
-CAD FILE IN MAIN VIEW IS DRAWN 1:1.  
-BORDER IS SCALED TO PRINT.  
-LAYED TO CUT IS CALLED "PICK"

MOCK UP QTY: 30 PROD QTY: 2500		OPEN LOCK PICK SET PICK BLADE	
MATERIAL: 1095 STEEL MATERIAL CERTS REQUIRED FINISH: DEBUR, TUMBLE		DATE: 5-18-2011	
TOLERANCES: X.XXX +/- 0.005" FRACTIONS +/- 1/64" ANGLES +/- 1/2		SIZE B	SCALE 2:1
		REV. A	DWG NO. ISON-1016-01-15

REV	DESCRIPTION	DATE	APPROVED
-----	-------------	------	----------

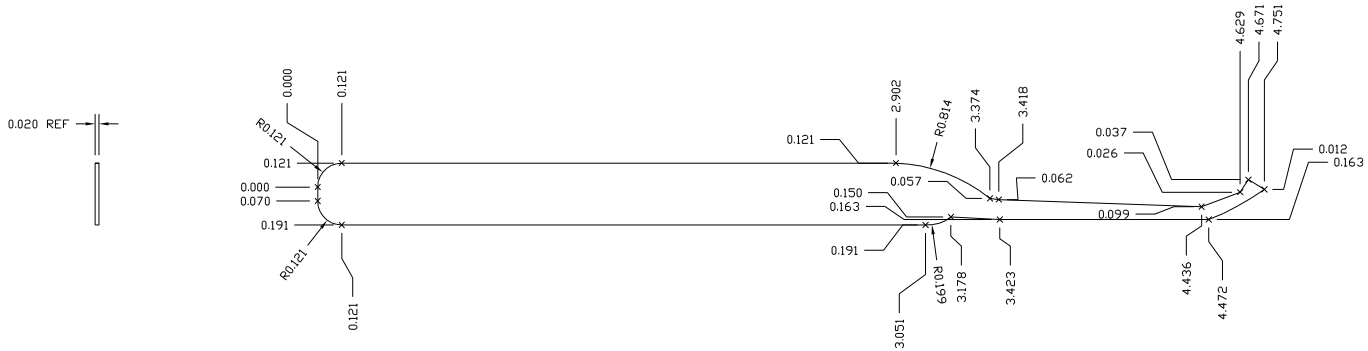

\*\*\*\*\*THIS VIEW IS 1:1 ONLY WHEN PRINTED  
ON 11X17 PAPER\*\*\*\*\*



\*\*\*\*\*THIS VIEW IS 1:1 ONLY WHEN PRINTED  
ON 11X17 PAPER\*\*\*\*\*

NOTES:  
 -CAD FILES AVAILABLE WITH ORDER.  
 -ACAD 2000 DWG OR ACAD DXF PROVIDED.  
 -CAD FILE IN MAIN VIEW IS DRAWN 1:1.  
 -BORDER IS SCALED TO PRINT.  
 -LAYED TO CUT IS CALLED "PICK"

MOCK UP QTY: 30  
 PROD QTY: 2500

MATL: 1095 STEEL  
 MATL CERTS REQUIRED  
 FINISH: DEBUR, TUMBLE

OPEN  
 LOCK PICK SET  
 PICK BLADE

TOLERANCES:  
 X.XXX +/- 0.005"  
 FRACTIONS +/- 1/64"  
 ANGLES +/- 1/2

DATE: 5-18-2011

SIZE	SCALE	REV.	DWG NO.
B	2:1	A	ISON-1016-01-16



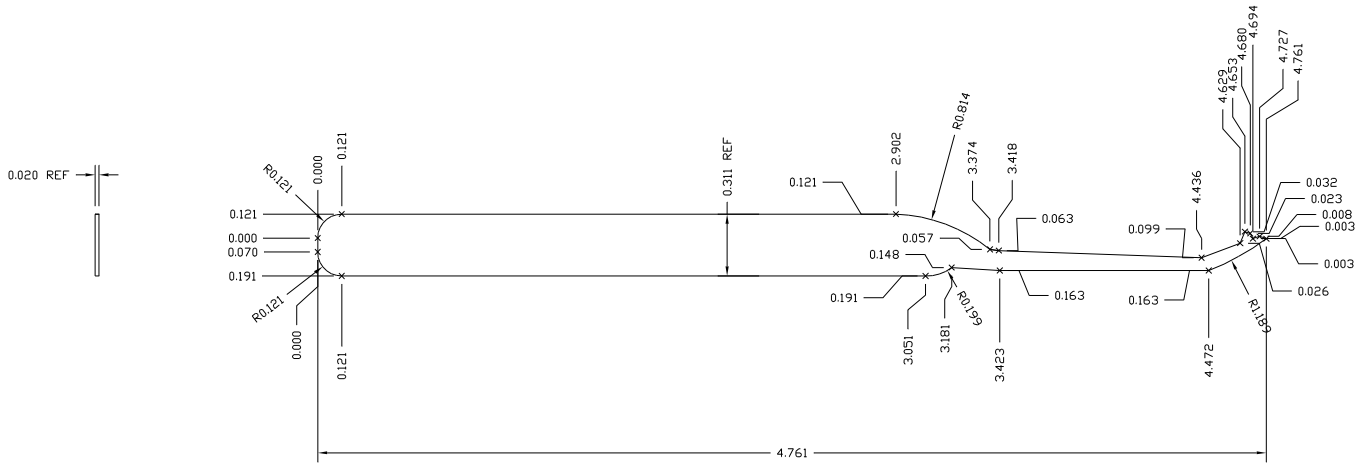

\*\*\*\*\*THIS VIEW IS 1:1 ONLY WHEN PRINTED  
ON 11X17 PAPER\*\*\*\*\*

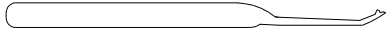

\*\*\*\*\*THIS VIEW IS 1:1 ONLY WHEN PRINTED  
ON 11X17 PAPER\*\*\*\*\*

NOTES:  
 -CAD FILES AVAILABLE WITH ORDER.  
 -ACAD 2000 DWG OR ACAD DXF PROVIDED.  
 -CAD FILE IN MAIN VIEW IS DRAWN 1:1.  
 -BORDER IS SCALED TO PRINT.  
 -LAYED TO CUT IS CALLED "PICK"

MOCK UP QTY: 30 PROD QTY: 2500		OPEN LOCK PICK SET PICK BLADE	
MATERIAL: 1095 STEEL MATERIAL CERTS REQUIRED FINISH: DEBUR, TUMBLE		DATE: 5-18-2011	
TOLERANCES: X.XXX +/- 0.005" FRACTIONS +/- 1/64" ANGLES +/- 1/2		SIZE B	SCALE 2:1
		REV.	DWG NO. ISON-1016-01-17

REV	DESCRIPTION	DATE	APPROVED
-----	-------------	------	----------

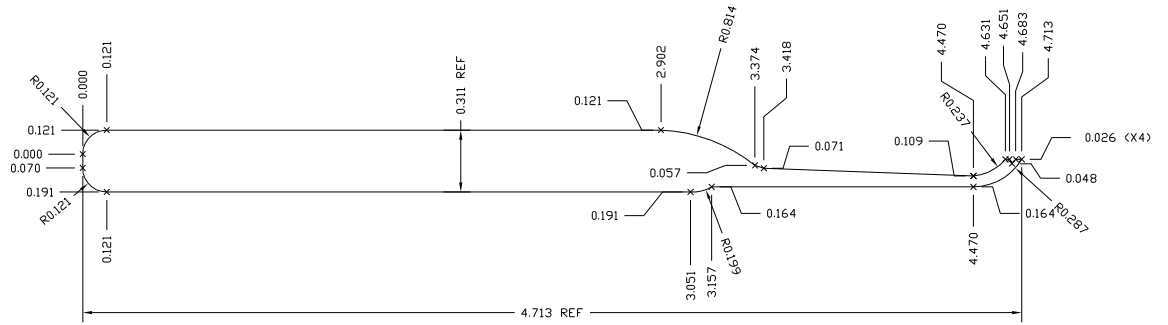
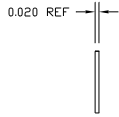

\*\*\*\*\*THIS VIEW IS 1:1 ONLY WHEN PRINTED  
ON 11X17 PAPER\*\*\*\*\*



\*\*\*\*\*THIS VIEW IS 1:1 ONLY WHEN PRINTED  
ON 11X17 PAPER\*\*\*\*\*

NOTES:  
-CAD FILES AVAILABLE WITH ORDER.  
-ACAD 2000 DWG OR ACAD DXF PROVIDED.  
-CAD FILE IN MAIN VIEW IS DRAWN 1:1.  
-BORDER IS SCALED TO PRINT.  
-LAYED TO CUT IS CALLED "PICK"

MOCK UP QTY: 30  
PROD QTY: 2500

MATL: 1095 STEEL  
MATL CERTS REQUIRED  
FINISH: DEBUR, TUMBLE

OPEN  
LOCK PICK SET  
PICK BLADE

TOLERANCES:  
X.XXX +/- 0.005"  
FRACTIONS +/- 1/64"  
ANGLES +/- 1/2

DATE: 5-18-2011

SIZE	SCALE	REV.	DWG NO.
B	2:1	A	ISON-1016-01-18





REV	DESCRIPTION	DATE	APPROVED
-----	-------------	------	----------

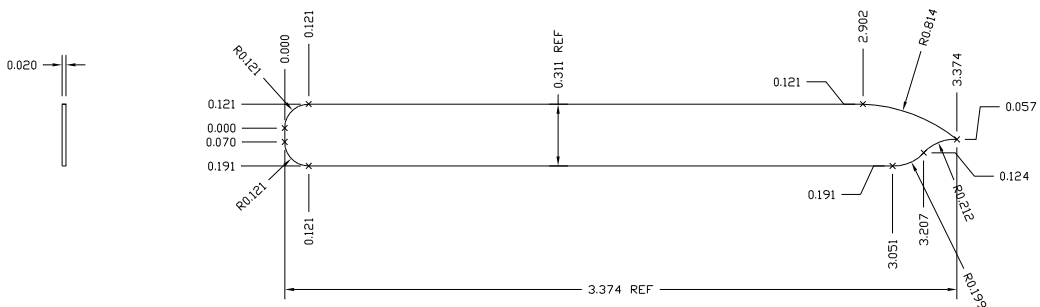

\*\*\*\*\*THIS VIEW IS 1:1 ONLY WHEN PRINTED  
ON 11X17 PAPER\*\*\*\*\*



\*\*\*\*\*THIS VIEW IS 1:1 ONLY WHEN PRINTED  
ON 11X17 PAPER\*\*\*\*\*

NOTES:  
-CAD FILES AVAILABLE WITH ORDER.  
-ACAD 2000 DWG OR ACAD DXF PROVIDED.  
-CAD FILE IN MAIN VIEW IS DRAWN 1:1.  
-BORDER IS SCALED TO PRINT.  
-LAYED TO CUT IS CALLED "PICK"

MOCK UP QTY: 1,200  
PROD QTY: 100,000

MATL: 1095 STEEL  
MATL CERTS REQUIRED  
FINISH: DEBUR, TUMBLE

TOLERANCES:  
X.XXX +/- 0.005"  
FRACTIONS +/- 1/64"  
ANGLES +/- 1/2

OPEN  
LOCK PICK SET  
PICK BLADE

DATE: 5-18-2011

SIZE	SCALE	REV.	DWG NO.
B	2:1		ISON-1016-02-01